

## **Regional Review Workshop on Completed Research Activities**

**Proceedings of Review Workshop on Completed Research Activities of Agricultural Engineering Research Directorate held at Batu Fishery & other Aquatic life Research Center, Batu, Ethiopia, 23-27 December 2020.**

**Editor: Kamil Ahmed**



**Oromia Agricultural Research Institute  
P.O. Box 81265, Finfinne, Ethiopia**

©2021 Oromia Agricultural Research Institute (IQQO)

**Correct citation:** Kamil Ahmed, 2020. Proceedings of Review Workshop on Completed Research Activities of Agricultural Engineering Research Directorate held at Batu Fishery & Other Aquatic life Research Center, Batu, Ethiopia 23-27 December, 2020. Oromia Agricultural Research Institute (IQQO), Finfinne, Ethiopia.

*Organized by: Communication Affairs Team of IQQO*

## Contents

<b>Agricultural Machinery and Farm Power Technologies</b>	<b>5</b>
Evaluation of Impact Hammer Mill for Limestone Crushing for Acidic Soil Treatment	5
Modification of Jimma Made Animal Drawn Manure Applicator	16
Redesigning of Asella Animal Drawn Wheat Row Planter	23
Development and Evaluation of Solar Powered Pesticide Sprayer for Large Fruit Trees	40
Performance Evaluation of Jima Drum Replaceable Multi-Crop Thresher for Wheat and Barley Threshing	52
Evaluation and Selection of Existing Machines for Sorghum Threshing	61
<b>Irrigation, Drainage and Water Harvesting Technologies</b>	<b>70</b>
Evaluation of Alternative, Fixed, Conventional Furrow Irrigation Systems and Irrigation Water Levels on Potato Yield at Oda Sirba Scheme	70
Design, construction and evaluation of runoff water harvesting Pond for smallholder farming	95
Effect of Decision Variables on Irrigation Performances and Yield of Onion Crop at Bako Woreda, West Shewa, Ethiopia	106
Effects of Furrow Irrigation Methods and Mulching on Growth, Yield and Water Use Efficiency of Tomato at Bako Tibe, Western Shewa	120
Effect of deficit irrigation on yield and water use efficiency of maize at Indris irrigation scheme of Eastern Wollega, Ethiopia	131
Effect of Alternate furrow irrigation with different irrigation intervals on yield, water use efficiency, and economic return of green Cob Maize ( <i>Zea mays</i> ) production at Wayu Tuka and Diga Districts, Western Oromia	144
Ground Water Quality Assessment and Testing for Irrigation Purpose, in irrigation potential of Eastern Hararge Zone	159
Technical Performance Evaluation of Selected Small Scale Irrigation Scheme in Arsi and Western Arsi Zone	179
<b>Post Harvest and Agricultural Product Processing Technologies</b>	<b>196</b>
Shelf Life Determination of Mango Juice Produce by Small-Scale Processing Techniques in Eastern Hararghe Zone	196

<b>Renewable Energy Technologies</b>	<b>207</b>
Adaptation and Evaluation of Pyrolysis Kiln Bone char Based Indigenous Fertilizer	207
Modification and Evaluation of Cardboard and Basket Model Solar Cooker	216

# Agricultural Machinery and Farm Power Technologies

## Evaluation of Impact Hammer Mill for Limestone Crushing for Acidic Soil Treatment

Gizachew Tefera

*Oromia Agricultural Research Institute, Bako Agricultural Engineering Research Center, P.O.Box 07, West Shoa, Bako, Email: gizachewtefera92@yahoo.com*

### Abstract

*Soil acidity becomes a serious threat to crop production in most highlands of Ethiopia particularly in Western parts of Oromia. Frequent tillage, removal of crop residues and mono-cropping and heavy rainfall contributes to soil acidification by leaching of cations. Agricultural limestone raises soil pH and reduces solubility of potentially toxic elements such as hydrogen, aluminum ( $Al^{3+}$ ) and manganese (Mn) at optimum nutrient uptake by crops. In an effort to alleviate the problems associated with soil acidity, a motorized limestone crusher was fabricated and evaluated. Performance of the prototype hammer mill machine, in terms of crushing capacity (kg/h), crushing efficiency (%), mean particle size (mm), fuel consumption (ml/kg) or energy consumption (wh/kg) was evaluated. Tests were carried out at engine speeds of 540, 720, 900 rpm, screen hole diameter of 2, 4, 6 mm and feed rates of 3.50, 7.00, 10.50 kg/min. The maximum crushing capacity of 630.32 kg/hr was recorded when the engine speed was 900 rpm, the screen hole diameter was 6mm and the feed rate was 10.50 kg/min whereas the minimum crushing capacity of 65.623 kg/h was observed when the hammer mill speed was 540 rpm, screen hole diameter 2 mm and feed rate 3.50 kg/min. The mean consumed energy ranged from 15.47 to 149.16 Wh/kg with hammer rotor speed of 540 to 900 rpm, screen hole diameter of 2 to 6 mm and the feeding rate of 3.5 to 10.5 kg/min. The mean particle size ranged from 0.121 to 0.448 mm with hammer rotor speed of 540 to 900 rpm, screen holes diameter of 2 to 6 mm and the feeding rate of 3.5 to 10.5 kg/min. It could be noticed that the lowest values of mean particle size were obtained at engine speed of 900 rpm, screen holes diameter of 2 mm and feed rate of 10.5 kg/min.*

**Keywords:** *Hammer mill, limestone, particles size and crushing.*

## **Introduction**

Agriculture contributes about 37% of the national (GDP), 73% of rural employment, and 70% of export earnings for the Ethiopian economy (FAO, 2019). However, soil acidity becomes a serious threat to crop production in most highlands of Ethiopia in general and in the western part of the country in particular. Studies show that about 43% of the total arable land area of Ethiopia is affected by acidity (Abdana, 2007). Soils around Asosa and Welega in aggregate:- 2.2% extremely acidic, 4% very strongly acidic, 32.8% strongly acidic, 27% moderately acidic, 3% slightly acidic and 1% neutral.

Major causes that speeds up soil acidification include (Wassie and Shiferaw, 2009; Wassie and Shiferaw, 2011; Tamene *et al.*, 2017): Frequent tillage, Removal of crop residues, Mono-cropping, Frequent application of urea. Soil acidity restricts crop production by impairing root growth and limiting nutrient and water uptake. Crops that are grown in acidic soils have a significantly stunted growth rate and are not very responsive to fertilizers (Mesfin, 2007). It also creates toxic soil solution that hinders the growth of roots and micro-organism activity. Lime can shift soil acidity towards neutral state and render nutrients more available to crops. Lime amounts of 2-5t/ha are typically needed to neutralize acid soils sufficiently for crop production, depending on the type of soil and levels of acidity (Tegbaru Bellete, 2015). Ethiopian government is planned to rehabilitate 226,000 ha of agricultural land by the end of the GTP II period. To achieve this, it is planned to produce 450,000-900,000 t of lime but, the achievement is quite low. Limestone is a geological nutrient asset that could sustain and enhance crop production is necessary for soil amendments. Agro-minerals are physically modified by grinding and hammer mill is used because of its ability to handle a wide variety of raw materials, handle hard stray objects and its robustness (Ajaka, 2014). In an effort to alleviate the problems associated with grinding of agricultural limestone, existing motorized limestone grinder should be evaluated. Therefore, this research study was intended to evaluate impact hammer mill for limestone grinding for acidic soil.

## **Materials and Methods**

### **Experimental Site**

The experiment was conducted at Bako Agricultural Engineering Research Center, which is located in East Wollega Zone of Oromia National Regional State, Ethiopia. The Center lies between 9<sup>o</sup> 04'45'' to 9<sup>o</sup> 07'15''N latitudes and 37<sup>o</sup> 02' to 37<sup>o</sup> 07'E longitudes.

## Materials used

Instruments such weighing balance, oven dry, tenso-meter, impact tester, different aperture size of sieve and basic manufacturing tools and equipment were used during prototype construction, data collection and evaluation.

**Particle-size distribution, crushing efficiency and capacity:** Weight retained in grams for each sieve size, (% weight retained for each sieve size, and cumulative weight % passing) for each sieve size of the particle size analysis of the limestone product from the grinding test were determined.

$$C_{eff} = \left( \frac{M_r}{M_i} \right) \times 100$$

$$\text{Crushing capacity} = \frac{\text{crushed limestone (kg)}}{\text{time taken (h)}}$$

Where:  $C_{eff}$  = Crushing efficiency

$M_i$  = mass of input material

$M_r$  = mass of recovered material

$$\text{Losses} = \left( \frac{M_b - M_a}{M_b} \right) \times 100$$

Where:  $M_b$  = mass before grinding

$M_a$  = mass after grinding

## Sieving method and analysis of lime powder

Sample of 500g was used for conducting sieve analysis and test sieves “nest” together to form a “stack” of sieves. In this work 20 cm diameter sieve was used and test sieve shaker provides both circular and tapping the energy and uniform mechanical motion. It is performed using a mechanical shaker for 10 minutes (GTM, 2015). The test was carried out as per ASTM D44 using standard sieve analyzer “Tylers” make. After the shaking was completed, the material on each sieve was weighed. The weight of the sample of each sieve was then divided by the total weight to give a percentage retained on each sieve. The size of the average particles on each sieves were analyzed to get the cut-point or specific size range captured on the sieve. The

effectiveness of agricultural lime (i.e. ground geological limestone) was accepted base on particle size to be 100% effective for particles <0.3mm; 60% effective between 0.3mm to 0.850 mm and; 10% effective for particles >0.850 mm (Stone *et al.*, 1998). To find the percent of crushed limestone passing through each sieve, the following equation was used,

$$\% \text{ Retained} = \frac{W_{\text{sieve}}}{W_{\text{Total}}} \times 100$$

Where:  $W_{\text{Sieve}}$  is the weight of crushed limestone in the sieve

$W_{\text{Total}}$  is the total weight of crushed limestone

To find the cumulative percent of crushed limestone retained in each sieve, add up the total amount of crushed limestone that was retained in each sieve and the amount in the previous sieves. The cumulative percent passing of the crushed limestone was found by subtracting the percent retained from 100%.

$$\% \text{ Cumulative Passing} = 100\% - \% \text{Cumulative Retained}$$

The values were then plotted on a graph with cumulative percent passing on the y axis and sieve size on the x axis.

## **Experimental Design**

The full factorial design was used for continuous grinding. For continuous grinding, an experimental plan comprising of three independent variables namely speed of mill (540, 720 and 900 rpm) and screen size having three levels (2, 4 and 6 mm) and feed rate having three levels (3.5, 7 and 10.5 kg/min) and dried Senkele limestone was selected purposely for evaluation. The ground product coming out of the grinding chamber was collected in a polythene bag, fastened directly under the mill to reduce the loss of fine particles. After the grinding operation, particle size distribution was determined by sieve analysis by taking a 500g from each representative sample. The experimental was conducted in a split- split- plot design having hammer mill speeds in main plots, sieve size in sub-plots and feeding rates in sub-sub-plots with three replications as a block. The design was laid as  $3^3$  factorial combinations in three replicates as block giving 81 total experimental units.



## Data Analysis

Data was subjected to analysis of variance using statically producer as described by Gomez and Gomez (1984). The analysis was made using Gen Stat 15<sup>th</sup> edition statistical software. When the effects of treatment were found significant, LSD test was performed to assess the difference among the treatments at 5% level of significance. The degree of relation and association between variables was expressed using the multiple regression equation and correlation coefficient.

## Results and Discussion

### Performance evaluation of the Machine

#### *Crushing capacity*

The mean crushing capacity and analysis of variance were presented in (Table 1). The statically analysis of ANOVA, clearly indicated that the crushing capacity of the prototype of limestone crusher/hammer mill was significantly ( $P < 0.05$ ) affected by hammer mill speed, screen hole diameter and feed rate. The combined effect of hammer mill speed and feed rate was also significant at the same level. The maximum crushing capacity of 630.32 kg/hr was recorded when the hammer mill speed was 900 rpm, the screen hole diameter 6 mm and the feed rate 10.50 kg/min. Generally, crushing capacity increased by increasing the hammer mill speed, feed rate and screen holes diameter. Refaay *et al.* (2016) showed the relationships between drum speed and machine productivity (ton/h) at different sieve diameters and feed rates. Increasing the speed increased the product with increasing the treatments of both the sieve diameter and feed in direct relationships.

Table 1. Crushing capacity (CC in Kg/hr) of limestone crusher at various hammer mill speeds, screen hole diameter and feed rates

Treatments		Feed rates(Kg/min)			Grand mean
Velocity (rpm)	Screen hole(mm)	3.50	7.00	10.50	
<b>540</b>	2	65.62 <sup>g</sup> ±4.12	134.29 <sup>f</sup> ±9.37	180.39 <sup>de</sup> ±6.25	
	4	148.76 <sup>ef</sup> ±4.87	222.62 <sup>d</sup> ±2.11	356.97 <sup>b</sup> ±7.48	
	6	279.42 <sup>c</sup> ±62.67	344.55 <sup>b</sup> ±54.87	489.64 <sup>a</sup> ±5.76	
<b>720</b>	2	80.16 <sup>f</sup> ±2.05	163.55 <sup>e</sup> ±5.72	196.46 <sup>c</sup> ±6.38	
	4	198.82 <sup>e</sup> ±42.00	313.87 <sup>d</sup> ±12.18	404.45 <sup>c</sup> ±2.97	
	6	441.73 <sup>c</sup> ±22.00	521.21 <sup>b</sup> ±12.62	596.66 <sup>a</sup> ±8.22	
<b>900</b>	2	88.56 <sup>i</sup> ±2.14	168.33 <sup>h</sup> ±3.30	212.87 <sup>g</sup> ±12.67	
	4	259.13 <sup>f</sup> ±3.97	338.57 <sup>e</sup> ±2.74	419.41 <sup>d</sup> ±12.44	

	6	469.89 <sup>c</sup> ±23.48	548.12 <sup>b</sup> ±14.19	630.32 <sup>a</sup> ±2.65	<b>306.46</b>
<b>SEM</b>			<b>24.78</b>		
<b>LSD</b>			<b>13.52</b>		
<b>CV (%)</b>			<b>8.09</b>		

SED: Standard errors of differences of means; LSD: Least significance difference; CV: Co-efficient of variation; (Two means are said to be similar or homogeneous if they are not significantly different from one another and those with different superscripts across the row are significantly different statistically at (p<0.05). Values were means ± standard deviation.

### Crushing efficiency

The mean percent crushing efficiency of the limestone crusher prototype and analysis of variance are given in (Table 2). Analysis of variance revealed that hammer mill speeds and screen hole diameter had significant (p < 0.01) effect on crushing efficiency. The effect of feed rate and the interaction of hammer mill speed and feed rate were significant at 5% level. As can be seen from (Table 2), increase in the hammer mill speed resulted in increased crushing efficiency. This could be due to the very fact that at higher hammer mill speed the energy imparted to the limestone was high hence causing higher crushing. The Results obtained showed that crushing efficiency increases with increasing screen holes diameter and hammer mill speed and similarly Babale (1988) reported similar findingstoo.

The maximum crushing efficiency 99.61% was observed when the hammer mill was operated at velocity of 900 rpm, at screen hole diameter of 6 mm and at feed rate of 10.50 kg/min; whereas the minimum crushing efficiency of 95.48% was observed when the hammer mill speed was 540 rpm, screen hole diameter of 2mm and feed rate 3.50 kg/min as can be seen from Table 2.

Table 2. Crushing efficiency (CE, %) of limestone crusher at various hammer mill speeds, screen holes diameter and feed rates

Treatments		Feed rate (kg/min)			Grand mean
velocity (rpm)	screen hole (mm)	3.50	7.00	10.50	
<b>540</b>	2	95.48 <sup>a</sup> ±0.05	96.06 <sup>b</sup> ±0.06	96.48 <sup>c</sup> ±0.08	
	4	97.73 <sup>a</sup> ±0.05	98.02 <sup>b</sup> ±0.05	98.34 <sup>c</sup> ±0.10	
	6	98.67 <sup>a</sup> ±0.05	98.95 <sup>b</sup> ±0.05	99.17 <sup>c</sup> ±0.07	
<b>720</b>	2	96.64 <sup>a</sup> ±0.05	97.10 <sup>b</sup> ±0.10	97.80 <sup>c</sup> ±0.05	
	4	98.22 <sup>a</sup> ±0.05	98.39 <sup>b</sup> ±0.05	98.70 <sup>c</sup> ±0.049	
	6	98.89 <sup>a</sup> ±0.05	99.05 <sup>b</sup> ±0.05	99.27 <sup>c</sup> ±0.05	
<b>900</b>	2	97.97 <sup>a</sup> ±0.16	98.56 <sup>b</sup> ±0.21	98.86 <sup>c</sup> ±0.16	
	4	99.05 <sup>a</sup> ±0.17	99.27 <sup>b</sup> ±0.17	99.50 <sup>c</sup> ±0.16	
	6	99.36 <sup>a</sup> ±0.16	99.48 <sup>b</sup> ±0.16	99.61 <sup>c</sup> ±0.16	98.33

<b>SEM</b>	<b>0.13</b>
<b>LSD</b>	<b>0.07</b>
<b>CV (%)</b>	<b>0.14</b>

SED: Standard errors of differences of means; LSD: Least significance difference; CV: Co-efficient of variation; (Two means are said to be similar or homogeneous if they are not significantly different from one another and those with different superscripts across the row are significantly different statistically at (p<0.05). Values were means  $\pm$  standard deviation.

### Consumed energy

The relationship between consumed energy (CE) and hammer rotor speed (V) at different feeding rates (F) and screen holes diameters (S) were illustrated in (Table 3). The obtained data showed that the consumed energy decreased with increasing feeding rate, screen holes diameter and hammer mill speed. The mean consumed energy ranged from 15.47 to 149.16 Wh/kg with hammer rotor speed of 540 to 900 rpm, screen holes diameter of 2 to 6 mm and the feeding rate of 3.5 to 10.5 kg/min. It could be noticed that the lowest values of consumed energy were obtained at engine speed (V) 900 rpm, screen hole diameter (S) 6 mm and feed rate (Fr) of 10.5 kg/min, however the highest values of consumed energy were obtained at engine speed (V) 540 rpm, screen hole diameter (S) 2 mm and feed rate (F) 3.5 kg/min and Dabbour *et al.* (2015) reports justify similar findings.

Table 3. Energy consumption (Wh/kg) of limestone crusher at various hammer mill speeds, screen hole diameter and feed rates

Treatments		Feed rate (Kg/min)			Grand mean
Velocity(rpm)	Screen hole (mm)	3.50	7.00	10.50	
540	2	149.16 <sup>a</sup> $\pm$ 9.31	72.95 <sup>b</sup> $\pm$ 5.04	54.11 <sup>c</sup> $\pm$ 1.87	
	4	65.61 <sup>a</sup> $\pm$ 2.17	43.80 <sup>b</sup> $\pm$ 0.42	27.33 <sup>c</sup> $\pm$ 0.57	
	6	36.48 <sup>a</sup> $\pm$ 7.10	28.96 <sup>b</sup> $\pm$ 4.16	19.92 <sup>c</sup> $\pm$ 0.23	
720	2	121.71 <sup>a</sup> $\pm$ 3.06	59.69 <sup>b</sup> $\pm$ 2.05	49.68 <sup>c</sup> $\pm$ 1.58	
	4	51.03 <sup>a</sup> $\pm$ 9.44	31.11 <sup>b</sup> $\pm$ 1.22	24.11 <sup>b</sup> $\pm$ 0.18	
	6	22.13 <sup>a</sup> $\pm$ 1.18	18.72 <sup>a</sup> $\pm$ 0.45	16.34 <sup>a</sup> $\pm$ 0.23	
900	2	110.16 <sup>a</sup> $\pm$ 2.62	57.94 <sup>b</sup> $\pm$ 1.12	45.96 <sup>c</sup> $\pm$ 2.69	
	4	37.64 <sup>a</sup> $\pm$ 0.58	28.80 <sup>b</sup> $\pm$ 0.23	23.27 <sup>c</sup> $\pm$ 0.69	
	6	20.80 <sup>a</sup> $\pm$ 1.08	17.80 <sup>a</sup> $\pm$ 0.47	15.47 <sup>a</sup> $\pm$ 0.06	46.32
<b>SEM</b>		<b>4.178</b>			
<b>LSD</b>		<b>2.28</b>			
<b>CV (%)</b>		<b>9.02</b>			

SED: Standard errors of differences of means; LSD: Least significance difference; CV: Co-efficient of variation; (Two means are said to be similar or homogeneous if they are not significantly different from one another) Values were means  $\pm$  standard deviation and those with different superscripts across the row are significantly different statistically at (p<0.05).

## Mean particle size

The relationship between mean particle size of the limestone particle after ground and hammer rotor speed (V) at different feeding rates (F) and screen holes diameter (S) were illustrated in (Table 4). The obtained data showed that mean particle size increased with increasing screen holes diameter and feeding rate and decreased with increasing hammer speed. The mean particle size ranged from 0.121 to 0.448 mm with hammer rotor speed of 540 to 900 rpm, screen holes diameter of 2 to 6 mm and the feeding rate of 3.5 to 10.5 kg/min. It could be noticed that the lowest values of mean particle size were obtained at engine speed (V) of 900 rpm, screen holes diameter (S) of 2 mm and feed rate (Fr) of 10.5 kg/min.

Table 4. Mean particle size (mm) of crushed limestone at various hammer mill speeds, screen holes diameter and feed rates

Treatments		Feed rate (Kg/min)			G.mean
V (rpm)	Scr. diameter	3.50	7.00	10.50	
540	2	0.28 <sup>a</sup> ±0.01	0.28 <sup>b</sup> ±0.03	0.28 <sup>a</sup> ±0.01	
	4	0.34 <sup>a</sup> ±0.00	0.35 <sup>b</sup> ±0.00	0.35 <sup>a</sup> ±0.01	
	6	0.44 <sup>c</sup> ±0.09	0.44 <sup>b</sup> ±0.02	0.45 <sup>a</sup> ±0.04	
720	2	0.18 <sup>b</sup> ±0.01	0.18 <sup>a</sup> ±0.01	0.19 <sup>a</sup> ±1.58	
	4	0.30 <sup>ab</sup> ±0.02	0.30 <sup>b</sup> ±0.02	0.30 <sup>a</sup> ±0.02	
	6	0.33 <sup>c</sup> ±0.04	0.33 <sup>b</sup> ±0.05	0.34 <sup>a</sup> ±0.05	
900	2	0.12 <sup>a</sup> ±0.01	0.12 <sup>a</sup> ±0.0	0.12 <sup>a</sup> ±0.00	
	4	0.16 <sup>c</sup> ±0.05	0.1637 <sup>b</sup> ±0.00	0.17 <sup>b</sup> ±0.00	
	6	0.20 <sup>a</sup> ±0.03	0.20 <sup>a</sup> ±0.00	0.21 <sup>a</sup> ±0.01	0.26
<b>SEM</b>		<b>0.02</b>			
<b>LSD</b>		<b>0.32</b>			
<b>CV (%)</b>		<b>7.74</b>			

SED: Standard errors of differences of means; LSD: Least significance difference; CV: Co-efficient of variation; (Two means are said to be similar or homogeneous if they are not significantly different from one another and those with different superscripts across the row are significantly different statistically at (p<0.05). Values were means ± standard deviation.

## Fuelconsumption

The analysis of variance, on fuel consumption of the crushing machine, revealed that hammer mill speed, screen holes diameter and feed rate had highly significant (P < 0.01) effects on the fuel consumption of the prototype crushing machine. In general, fuel consumption of the crushing machine increased with in increasing of hammers mill speeds and decrease with increasing screen holes diameter and increase with increasing of feed rates. The mean fuelconsumption ranged from 8.62 to 47.99 ml/kg with hammer rotor speed of 540 to 900

rpm, screen holes diameter of 2 to 6 mm and the feeding rate of 3.5 to 10.5 kg/min. It could be noticed that the lowest values of fuel consumption were obtained at engine speed (V) 540 rpm, screen hole diameter (S) 6 mm and feed rate (Fr) of 3.5 kg/min, however the highest values of fuel consumption were obtained at engine speed (V) 900 rpm, screen hole diameter (S) 2 mm and feed rate (F) 10.5 kg/min. (Table 5) indicating that fuel consumption would be increased with increasing rate of work and feed though it appears to decrease with increasing screen hole diameter manifesting the effect of screen hole diameter on fuel consumption during crushing.

Table 5. Fuel consumption of engine (FC, ml/kg) for hammer mill prototype when operated at different speeds, screen holes diameter and feed rates

Treatments		Feed rate(Kg/min)			Grandmean
Velocity (rpm)	Screen hole (mm)	3.50	7.00	10.50	
540	2	14.66 <sup>c</sup> ±1.07	16.98 <sup>b</sup> ±0.55	18.34 <sup>a</sup> ±0.75	26.37
	4	10.54 <sup>ef</sup> ±0.85	12.67 <sup>d</sup> ±0.94	15.26 <sup>c</sup> ±0.85	
	6	8.62 <sup>s</sup> ±0.51	9.72 <sup>f</sup> ±0.52	11.40 <sup>e</sup> ±0.70	
720	2	29.00 <sup>e</sup> ±0.63	34.33 <sup>c</sup> ±0.76	39.33 <sup>a</sup> ±0.25	
	4	20.98 <sup>h</sup> ±0.54	27.45 <sup>f</sup> ±1.03	35.54 <sup>b</sup> ±0.94	
	6	20.58 <sup>h</sup> ±1.35	25.85 <sup>s</sup> ±1.73	31.37 <sup>d</sup> ±0.55	
900	2	35.81 <sup>d</sup> ±0.41	39.70 <sup>c</sup> ±0.43	48.00 <sup>a</sup> ±0.68	
	4	28.82 <sup>s</sup> ±0.45	34.92 <sup>e</sup> ±0.21	42.24 <sup>b</sup> ±0.50	
	6	27.97 <sup>g</sup> ±0.23	33.01 <sup>f</sup> ±0.31	38.99 <sup>c</sup> ±0.11	
<b>SEM</b>		<b>0.85</b>			
<b>LSD</b>		<b>0.50</b>			
<b>CV (%)</b>		<b>3.49</b>			

SED: Standard errors of differences of means; LSD: Least significance difference; CV: Co-efficient of variation; (Two means are said to be similar or homogeneous if they are not significantly different from one another and those with different superscripts across the row are significantly different statistically at (p<0.05). Values were means ± standard deviation.

### Sieve particle size analysis

Sample of 500 g was used for conducting sieve analysis and test sieves “nest” together to form a “stack” of sieves. In this work 20 cm diameter sieve was used and performed using a mechanical shaker within 10 minutes and carried out as per ASTM D44 using standard sieve analyzer “Tylers” make. After the shaking was completed, the material on each sieve was weighed and divided by the total weight to give a percentage retained on each sieve. The size of the average particles on each sieve then was analyzed to get the cut-point or specific size range captured on the sieve.

To find the cumulative percent weight of crushed limestone retained in each sieve, add up the total weight of crushed limestone that was retained in each sieve and the amount in the previous sieves. The cumulative percent passing of the weight of crushed limestone was found by subtracting the percent retained from 100%. The values are then plotted on a graph with cumulative percent passing on the y axis and sieve size on the x axis.

Table 6. Cumulative percent passing through sieve and % retained for engine speed of 900 rpm, screen hole diameter of 6 mm and feed rate of 10.5 kg/mi (at maximum efficiency and crushing capacity).

Sieve No	Mesh size (mm)	WR	%R	CW	%CUM	%Fine
8	2	0	0	0	0	100
16	1.18	2.71	0.542	2.71	0.542	99.46
30	0.6	17.68	3.54	20.39	4.08	95.92
50	0.3	39.27	7.85	59.66	11.93	88.07
100	0.15	189.15	37.83	248.81	49.76	50.24
200	0.075	228.35	45.67	477.16	95.43	4.57
(Pan)		22.77	4.554	499.93	99.99	0.01

Coefficient of Uniformity (CU) (ASTM D2487) =  $D_{60}/D_{10} = 0.19/0.0825 = 2.3$ ,  $D_{30} = 0.12$

Coefficient of curvature (Cc) (ASTM D2487) =  $(D_{30})^2/(D_{10} \times D_{60}) = (0.12)^2 / (0.0825 \times 0.19) = 0.92$

$D_{60}$  = Diameter corresponding to 60% finer in the grain size distribution.  $D_{30}$  = Diameter corresponding to 30% finer in the grain size distribution.  $D_{10}$  = Diameter corresponding to 10% finer in the grain size distribution.

## Conclusions and Recommendations

### Conclusions

Based on the results obtained, regarding crushing capacity (kg/h), crushing efficiency (%), geometric mean diameter, fuel consumption and energy consumption, it can be concluded that the performance of the prototype machine was very much acceptable with high prospect for extending the technology. In light of the aim and objectives earlier stated, the tested results showed that the machine gave a satisfactory performance in output, energy and fuel consumption. The machine also has room for easy maintenance activities such as replacement of screen, hammers and cleaning of the bottom casing. The utilization of the machine is not limited to only limestone and it can be used in poultry and fish food processing and iodized salt processing and can be milled provided they are dried. Lastly, the fabricated machine was constructed with locally sourced material and has fewer components; hence, the purchase price of the machine can be kept low.

## Recommendations

Based on the finding obtained, the prototype of hammer mill developed for use with agricultural limestone appear to be most efficient at cylinder speed of 900 rpm, screen hole diameter of 6 mm and the feed rate of 10.50 kg/min. Nonetheless, it is recommended that, the machine can be re-evaluated at more engine speeds, feed rates and screen holes diameter using different physical and mechanical properties of limestone.

## References

- Abdenna, Deressa, Negassa, Chewaka and Tilahun Geleto. 2007. Inventory of Soil Acidity Status in Crop Lands of Central and Western Ethiopia. "Utilization of diversity in land use systems: Sustainable and organic approaches to meet needs" October 9-11, 2007.
- Ajaka, Oyedele. 2014. Design Fabrication and Performance Testing of a Laboratory Size Hammer Mill. *International Journal of Engineering and Advanced Technology Studies*. Vol. 2.
- Babale, M., 1988. Fabrication of an egusi shelling machine. *Agric. Engineering Dept.*,
- Dabbour, Bahnasawy M.I., A., Ali S., and Haddad El- Z. 2015. Grinding parameters and their effects on the quality of corn for feed processing. *Journal of Food Process Technology*, 6: 482.
- Desta, Beyene. 1988. Soil Science Research in Ethiopia: A proceedings of the first soil science research review workshop, 11-14 February 1986, IAR, Addis Ababa, Ethiopia.
- FAO. 2019. The future of livestock in Ethiopia Opportunities and challenges in the face of uncertainty. GTM-20. 2015. Test method for the grain-size analysis of granular materials. Department of Transportation, Revision 5, State Of New York.
- Kefeni Kejela. 1992. Assessing soil degradation with emphasis on soil productivity in the Anjeni area, Gojam. Ethiopian Institute of Agricultural Research, Addis Ababa, Ethiopia. pp. 78–91.
- Mesfin Abebe. 2007. Nature and Management of Acid Soils in Ethiopia. Haramaya University College of Agriculture. pp. 18.
- Refaay, and El\_Sayed A. S. 2016. Developing a hammer mill for grinding seashells. *Journal of Soil Science and Agricultural Engineering*. Mansoura University, Egypt. Vol. 7 pp: 801 – 808.
- Stone Y., Ahern CR., Blunden B. 1998. Acid sulfate soils manual. (Acid Sulfate Soils Management Advisory Committee; Wollongbar, NSW).
- Tamene L; Amede T; Kihara J; Tibebe D; Schulz S. (eds.). 2017. A review of soil fertility management and crop response to fertilizer application in Ethiopia: towards development of site- and context-specific fertilizer recommendation. CIAT Publication No. 443. International Center for Tropical Agriculture (CIAT), Addis Ababa, Ethiopia. 86 p.
- TameneLulseged; Amede Tilahun; Kihara J; TibebeDegefi; Schulz S. (eds.). 2017. A review of soil fertility management and crop response to fertilizer application in Ethiopia: towards development of site- and context specific fertilizer recommendation. CIAT Publication No. 443..86p
- Taye Bekele. 2008. Estimation of Lime Requirement. Training manual for regional soil testing laboratory heads and technical. National soil testing center, Ministry of Agriculture and Rural Development.
- Tegbaru Bellete. 2015. 2<sup>nd</sup> IPI; MoANR, ATA and Hawassa university joint symposium. Hawassa University, Ethiopia.
- Wassie Haile and ShiferawBoke. 2009. Mitigation of soil acidity and fertility decline challenges for sustainable livelihood improvement: research findings from southern region of Ethiopia and its policy implications.
- Wassie Haile and ShiferawBoke. 2011. on-Farm Verification of Lime and NPK Fertilizers Effects on the Tuber Yield of Irish Potato (*Solanum Tuberosum*) on Some Acidic Soils of Southern Ethiopia. *Journal of the Dry lands*, 4(1): 283-288.

# Modification of Jimma Made Animal Drawn Manure Applicator

Tamiru Dibaba\*, Rabira Wirtu

*Oromia Agricultural Research Institute, Jimma Agricultural Engineering Research Center, Jimma, Oromia, Ethiopia.*

*\*Correspondent author e-mail: [tamdibaba@gmail.com](mailto:tamdibaba@gmail.com)*

## Abstract

*Organic manure plays important role to yield productivity of soil. It is good quality source of nitrogen phosphorus and excellent source of calcium and potash. The evenly spreading of manure on farm field is extremely important to achieve better effect. The modification of existing manure applicator which could not evaluate was done and field test was done. Therefore, finally the performance of the spreader was done and its capacity, application rate, and delivery rate were studied. In general, an animal drawn farmyard manure spreader has a capacity of 178 to 200kg considering the minimum bulk density of manure  $0.66\text{g/cm}^3$ . This manure applicator gave manure application rate 2.38 to 7.1 t/ha for the manure delivery rate 0.44 to 1.09kg/sec at opening of manure delivery of hopper 7 to 12cm respectively. Hence, based on this result and made minor modification especially incorporate agitator, it was recommended that it is better to used it than existing method of spreading by manual.*

**Keywords:** *Animal drawn, Manure applicator, farmyard spreader*

## Introduction

Modernization of agriculture depends on use of appropriate machinery for enhancing resource use efficiency and productivity in agriculture. It would be difficult for farmers in the developing countries to meet the food production targets of the coming decade without access to more and better farm power and improved implements and equipments to utilize that power effectively and efficiently. Agricultural machines play the role of exponents of progress in agricultural pursuits and welfare of farming community. The present investigation was carried out towards the development of prototype, economically feasible, eco-friendly and simple method of operation. Livestock manures represent a valuable resource that, if used appropriately, can replace significant amounts of chemical fertilizers [VANDER MEER, H.G., *et al.*, 1987]. The manure applicator is useful to marginal and small scale farmers. In organic farming, manure applicator is promising solution for uniform spreading of farm yard manure over the field.



Farm yard manure is mainly being applied through manual broadcasting, resulting more labours and time per unit area with poor application uniformity and wide variation in the application rate.

Farm yard manure is mainly being applied through manual broadcasting, resulting more labours and time per unit area with poor application uniformity and wide variation in the application rate. The bullock-cart/tractor trailers are being used to transport the FYM from the compost pit to the field and manure is stack piled in the field. The spreading of stack piled manure is performed manually with spade, which involves human drudgery. Research has been shown that the stack piled manure loses about 21% of its nitrogen to the atmosphere. The small and marginal farmers have a pair of bullocks instead their limited use in tillage, sowing, intercultural and transport operations about 58 days/year and high maintains cost in slack period (Rs.55/day). Hence, there is need to increase the working hours of bullocks for other agricultural operations, *viz.*, spreading of farm yard manure in the field.

The existing bullock carts used for transport of manure to the field could be modified for the FYM spreading operation also (Singh and Singh, 2006). In recent days, organic farming is a promising solution in agriculture farming, rather than the use of chemical fertilizers. Keeping of all these facts in mind, an animal drawn FYM applicator to be developed for uniform spreading of manure and eliminate the human drudgery involved in spreading of FYM in field. Utilization of bullocks for manure spreading in field will increase the additional working hours of 24-36 hour per year for two seasons and lower the maintenance cost of animals about Rs.400-600 per pair per year (*Singh and Singh, 2006*). In agriculture, manure, compost, or sewage sludge are generally applied with manure applicators. Keeping in view of drudgery involved, a suitable animal drawn manure applicator is need of hour for usage.

Crops need nutrients to grow and develop and they draw these nutrients from the soil. If this withdrawal is not compensated for, the crop yield goes down progressively. This withdrawal is completed through fertilizers and manures to maintain the productivity of the soil and to achieve higher yields. Soil fertilization is carried out by means of organic matter in the form of farmyard manure, liquid manure faces, plants or straw and mineral matters. The manure has to be handled in bulk. So, the problem faced during application of manure differs from that of other fertilizer not only with respect to the rate to be applied per hectare, but also with respect to non-uniformity of the size of the particles. The overall goal for any field receiving manure

should be how many Gallons or tons of manure should be applied to a known area and to apply the manure as uniformly as possible. Organic manure is considered as the eco-friendly bio-fertilizer for the highly polluted modern era.

Today's farmer needs machinery which can spread the manure effectively with least cost with consumes low power. Keeping all facts in mind an animal drawn FYM spreader is developed for uniform spreading of manure and eliminates the human drudgery involved in spreading of manure in the field.

Therefore, to fill this gap different research was done to design and develop manure applicators. Out of this the Jimma Agricultural Engineering Research Center would be tried the good mechanism which means using conveyor mechanism to deliver the manure. The Jimma made manure applicator has good distribution mechanism, but the conveyor used for transport the manure had problem. This part and over all materials used would be very difficult for driven by animals. So, modification should be necessary for such parts and the performance of this machine didn't measured due to failure occurred on station evaluation. Therefore, the objectives of this work was to modify and evaluate the manure spreader

## Materials and Methods

### Material

The manure applicatore prototype, manure and measuring instruments were used as the main experimental materials. Since the machine is an Animal drawn, thus, a horse was hired and used as the power source of pulling the applicator during the field evaluaton.



Fig 1. The Manure applicatormachine (left), the hopper part filled with manure

## Methods

The study was conducted at Kersa woredas of Jimma zone. The applicator was modified in the center and the manure would be prepared at farmers' gardens. After the manure was prepared using a horse to pulling the manure spreader, filled with the farmyard manure during the testing of manure spreader. The speed of operation would be determined by recording the time of travel of horse for 10m distance with three replications for each opening.



Fig 2. Field testing of the Manure applicator machine

## Hopper Capacity

The volume of hopper would be determined by the following formula (Khurmi PS, Gupta JK., 2005):

$$V = \left(\frac{l_1 + l_2}{2}\right)wh + bwh$$

Where: V is the volume of hopper

$l_1$  and  $l_2$  are top and bottom length of manure box

w is width of manure box

h is height of manure box and b is the depth of upper box

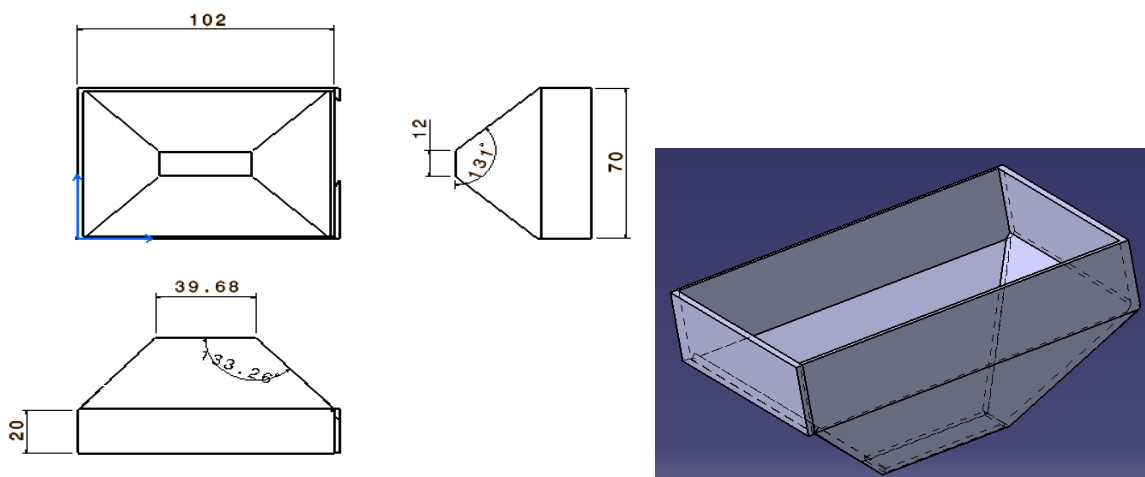

Fig 3: Drawings of the hoper part

### **Application rate**

After operation manure of 10min length in the direction of line of travel was collected and weighed. The density of the manure, application rate and the moisture content were determined using the following equation (khurmi and Gubta, 2005):

$$AR = \frac{Q * 10,000}{W * V}$$

Where: AR-application rate kg/ha

Q- Manure delivery rate in kg/s

W-width of application in m

V-is the forward speed in s

### **Moisture content of the manure**

$$mc = \frac{Wi - Wf}{Wf} * 100$$

### **Bulk density of the manure**

$$Bd = \frac{mass}{volume}$$

## **Results and Discussion**

The modified animal drawn conveyor manure application rate system was tested in the field for manure application rate and uniformity of manure distribution using the horse for traction as shown in figure below. The manure spreader was filled with the farmyard manure which the hopper has a capacity of 0.27m<sup>3</sup>. The bulk density, moisture content and angle of friction of the manure were 0.66g/cm<sup>3</sup>, 26.31% and 38.5<sup>0</sup> respectively. The manure spreader was operated in the field and time for 10m travel was recorded for both opening of the outlet.

### **Capacity of the applicator**

R. C. Singh and C. D. Singh (2014) develop animal drawn spreader existing bullock carts which used for transport of manure to the field .it is modified for FYM spreading operation. The developed farmyard manure spreader had 480 kg capacity and gave manure application rate of 5 to 10 t/ha for the manure delivery rate of 0.38 to 0.74 kg/s at the speed of 2.4 km/h, respectively.

Table 1. Field performance of manure applicator at different opening

Parameter	Speed of operation (m/s)	Manure delivery rate (kg/sec)	Application rate (kg/m <sup>2</sup> )
Open 7cm	0.915 <sup>a</sup>	0.438 <sup>b</sup>	0.248 <sup>b</sup>
Open 12cm	0.730 <sup>a</sup>	1.095 <sup>a</sup>	0.730 <sup>a</sup>
SE	0.094	0.052	0.021
LSD	0.1877	0.0018	0.0061
CV (%)	11.42	4.31	6.75

As shown from the table 1 the application rate and delivery rate are significantly different from one another while the speed of operation not significantly different.

Table 2. Manure distribution uniformity based on opening of the hopper outlet

Manure delivery (kg/min)	Speed (m/s)	Application rate (t/ha)	Field capacity(ha/hr)
25.96	11	2.38	0.65
77.4	13	7.1	0.55

## Conclusions and Recommendations

### Conclusions

An animal drawn farmyard manure spreader had a capacity of 178 to 200kg considering the minimum bulk density of manure 0.66g/cm<sup>3</sup>. This manure applicator gave manure application rate 2.38 to 7.1t/ha for the manure delivery rate 0.44 to 1.09kg/sec at opening of manure delivery of hopper 7 to 12cm respectively.

### Recommendations

The machine is good for farmers to spreading manure if some problems will be solved:

- The manure required additional agitating mechanism due to high cohesion force between manure
- The conveyor required accuracy chain and reciprocate assembling

## Reference

- Khurmi PS, Gupta JK (2005). A Textbook of Machine Design, First Multicolor Edition, Eurasia Publishing House Ltd. 7361, Ram Nagar, New Delhi-110055. Pp.505-556.
- R.C Singh and C.D Singh —Design and development of animal drawn farmyard manure spreader, *African journal of agricultural research*, Vol.9, October 2014.
- Singh, R.C. and Singh, V.V. (2006). Development and performance testing of animal drawn manure spreader. Prog. Rep. (2006-2008), *AICRP on UAE*, CIAE, Bhopal centre (India), pp. 65-79.
- VANDER MEER, H.G., UNWIN, R.J., VAN DIJK, T.A., ENNIK, G.C., Animal Manure on Grassland and Fodder Crops: Fertilizer or Waste? (H.G. VAN DER MEER, R.J. UNWIN, T.A. VAN DIJK, G.C. ENNIK, Eds.), *Development Plant Soil Sci.* **30** (1987) 388 pp., Martinus Nijhoff Publishers, Dordrecht, The Netherlands.

# Redesigning of Asella Animal Drawn Wheat Row Planter

Ashebir Tsegaye\*, H/Micka'el Fayisa and Abayineh Gizaw

*Oromia Agricultural Research Institute, Asella Agricultural Engineering Research Center, P.O.Box 06 Asella, Oromia, Ethiopia. \*Corresponding author e-mail: [tsegayeashebir@gmail.com](mailto:tsegayeashebir@gmail.com)*

## Abstract

*This study was undertaken to redesign, fabricate and evaluate the performance of animal drawn seed drill prototype capable of drilling wheat and barley seeds and applying fertilizer at predetermined row spacing and depths. Physical properties of seeds involved in the study were investigated to optimize the design of the seed drill's components. The developed seed drill machine, consisting of a frame, seed and fertilizer hopper, seed metering devices, seed delivery tube, adjustable furrow opener, and drive wheels. The performances were evaluated in terms of Seed and fertilizer rate, row spacing, depth of seed placement, plant count/stand, field capacity and field efficiency. The investigation revealed that the sphericity of Hidase, Digelu, Ogolcho, and Kekeba wheat varieties were 65.81 %, 64.79% and 62.62 %, respectively. Row to row spacing can be 20 cm and depth also adjustable to 5 to 7 cm as per wheat agronomic requirement. The developed four row animal drawn seed drill was tested in the laboratory and field. The seed rate was calibrated and observed that 127 kg/ha with a middle flap position adjustment which is laying in the acceptable range of recommended seed rate. There was no visible damage observed. The mean field capacity and field efficiency were 0.112 ha/hr and 81.78% at speed of 1.71km/hr. 310 to 318 plant populations per meter square (1 m<sup>2</sup>) area were observed during field germination count. Based on the performance evaluation results, it is concluded that the developed seed drill can be effectively and economically used by the majority of farmers.*

**Key words:** Redesigning, Animal Drawn, Wheat Row Planter, performance

## Introduction

Wheat is the second important cereal crop in Ethiopia with annual production of about 3.43 million tons cultivated on area of 1.63 million hectares (CSA, 2013). According to CSA (2013) wheat occupied about 17% of the total cereals cultivated area with average national yield of 2.11 t/ ha which is low compared to the world average of 4 t/ha (FAO, 2009).

These low production and productivity of the crop are all attributed to low use of improved farm inputs (biological and mechanical), dependency on traditional farming system and rainfall. Traditional farming system in the country is the major factor contributing to lower production. The traditional method of row planting method is tedious, causing fatigue and

backache due to the longer hours required for careful hand metering of seeds and fertilizer. The importance of machine in agricultural operations in the world today should never be underestimated, be it manually operated or powered. One of the major problems confronting the farmers in Ethiopia is in the area of planting seeds because of the limited economy they can put up and most of them cannot afford the money to procure or hire sophisticated machinery that can be used for planting.

The planting operation is one of the most important cultural practices associated with crop production. Increases in crop yield, cropping reliability, cropping frequency and crop returns all depend on the uniform and timely establishment of optimum plant populations. Proper application of fertilizer at proper location and proper placement of seed row spacing has a good effect on yield growth. The main reason for increase in yield is the uniform and controlled application of fertilizer with respect to seed in a concentrated band at about 50 mm below and 50 mm away from the seed.

A developing country like Ethiopia is expected to continue to rely more on animal drawn tools for the predictable future for crop cultivation. The use of animal drawn tools for crop cultivation is still predominant in Ethiopia because tractors require resources that many farmers do not have easy access to tractors. These small holder farmers still continue to plant manually, the result of which is low productivity of the crops. It is therefore necessary to develop a low cost animal drawn row planter that will reduce tedium and drudgery and enable small holder farmer to produce more foods and also environmental friendly.

Under intensive cropping, timeliness of operations is one of the most important factors which can only be achieved if appropriate use of agricultural machines is advocated. Manual method of seed drilling, results in low seed placement, spacing efficiencies and serious back ache for the farmer which limits the size of field that can be row planted.

The federal and regional agricultural engineering research centers have been tried to develop and adapt prototypes of wheat row planters. Other private companies and individuals including farmers are also develop row planting implements to commercialize on larger scale. Various types of wheat row planter have been developed with different design approaches which have their advantage and disadvantages and also operational limitation.



Asella Agricultural Engineering Research Center has been developed, modified, evaluated and demonstrates continuously from four up to eight row animal drawn wheat seed drill. These seeder were designed to plant only wheat at a seed rate of 125 to 150 kg/ha with no fertilizer metering device, i.e fertilizer were broadcasted by hand before sowing of wheat. Even though, wheat seed drills were designed, modified, tested and evaluated continuously by different researchers at the center, still there is no proven wheat seed drill that can be used under farmers' conditions.

In general, the drawback observed to-date is that available wheat seed drills are not able to maintain uniform seeding rate, fertilizer and seed application at a time. To achieve the best performance from a seed driller, the observed limitations would be optimized by proper design and selection of the components required on the machine to suit the needs of crops. Therefore, this research activity was initiated to redesign, develop and evaluate the improved animal drawn wheat seed drill.

## **Material and Methods**

This section deals with the materials and methods employed for development of four row animal drawn wheat seed drill. The materials used to develop the planter and equipment used to test the developed row planter has been discussed under respective title.

### **Physical Properties of Some Selected Wheat Variety**

The physical properties of seeds are important factors for the design of different components of the machine. The most common wheat varieties of Digelu, Kekeba and Ogolicho wheat seed varieties were selected for the study to determine the geometrical size of the seed based on their physical properties. Parameters like thousand grain mass, geometrical size, sphericity, bulk density and angle of repose were considered.

### **Descriptions of Improved Row Planter**

The developed animal drawn wheat row planter prototype (fig.1) were simple and consists of the following main components; frame, seed and fertilizer hopper, furrow openers, ground wheel, metering device (flute), seed and fertilizer delivery tubes, hitching system, handle and beam.

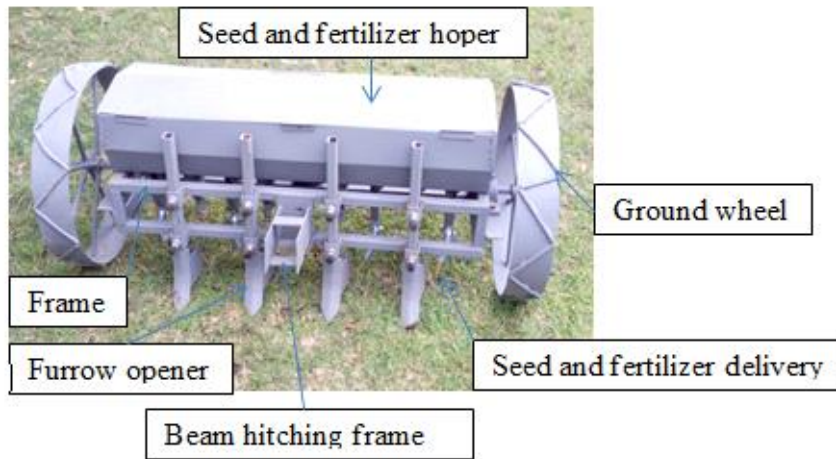

Fig.1. Pictorial description of the row planter

### Frame

The frame is the skeletal structure of the planter on which all other components are mounted on it. Frame of planter has to be rigid and strong as all parts are mounted on it. It is made from mild steel square pipe (fig.1). The furrow openers, metering mechanism, handle, hitch attachment and hopper were attached to the frame.

### Seed and fertilizer hopper

The hopper is feed in a vertical position only. The material used for the construction was sheet metal with thickness of 1.5 mm. For designing the seed hopper, the average bulk density of wheat seeds  $791.5 \text{ kg/m}^3$  and the angle of repose  $26.09^\circ$  were considered. Therefore, the angle of the hopper side wall was kept as  $62^\circ$ . Hence, the designed hopper has trapezoidal shape at the bottom half and rectangular shape at upper half height and divided into two compartments along its length; one for fertilizer and the other one for seeds. The volume of hopper was determined using the following formula (Olaoye and Bolufawi, 2001).

$$V = \frac{S_R}{nBD}$$

Where:  $S_R$  = seeding rate (kg/ha)

$n$  = number of refilling per hectare

$BD$  = bulk density of the seeds ( $\text{kg/ m}^3$ )

$$V = \frac{125(\text{Kg} / \text{ha})}{8 \times 791.5(\text{Kg} / \text{m}^3)} = 0.02 \text{m}^3$$

Actual volume of the seed hopper was determined on the basis of the assumed dimensions of the box listed below.

- Top width (b) = 28 cm
- Bottom width (a) = 20 cm
- Height (h<sub>R</sub>) = 9 cm
- Height (h<sub>T</sub>) = 8.5 cm
- Length = l = 94cm
- V<sub>R</sub> = Volume of rectangular part of the hopper
- V<sub>T</sub> = Volume of trapezoidal part of the hopper

Using the above assumed dimension of the box, its volume was calculated by the following formula (Sharma and Mukesh, 2010).

$$V = V_R + V_T = l * b * h_R + \frac{1}{2}(2 * a + 2 * l) * h_T * b$$

$$V = V_R + V_T = 94 * 28 * 9 + \frac{1}{2}(2 * 20 + 2 * 94) * 8.5 * 28$$

$$V = 50,820 \text{cm}^3 = 0.05 \text{m}^3$$

Hence, designed hopper has two compartments and equally separated, one for seeds and one for fertilizers which is 0.025 m<sup>3</sup> separately as shown in figure 4.

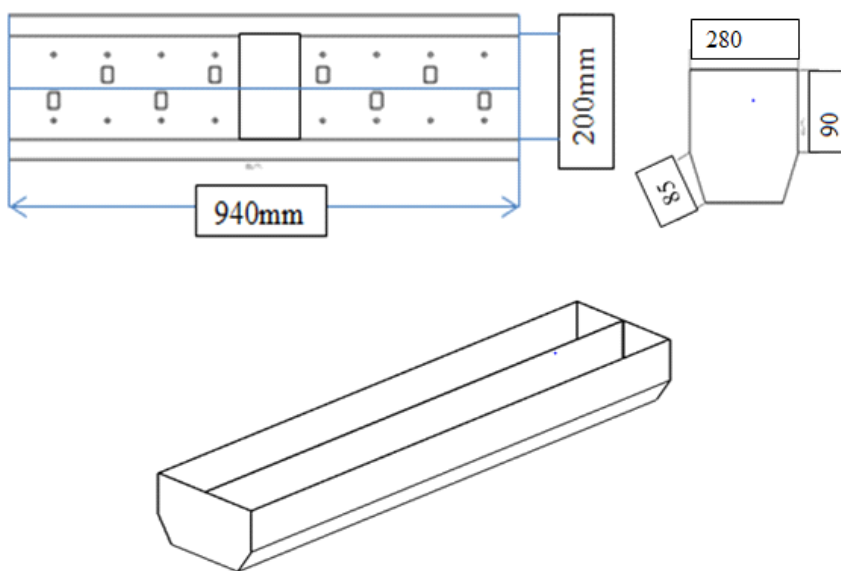

Figure 2. Isometric view of seed and fertilizer hopper

### Metering mechanism

Metering mechanism is the heart of planting machine which is distributes seeds uniformly at the desired application rates. The metering flute roller is derived directly by the ground wheel through drive shaft. The length, depth and number of flute on the seed metering roller were determined from the recommended seed rate per hectare. In this design, the seed metering flute lifts the seeds from the bottom flap of flute house and drops the seed and fertilizer into seed tube. The size of flutes was determined on the basis of recommended seed rate per hectare (RNAM, 1991).

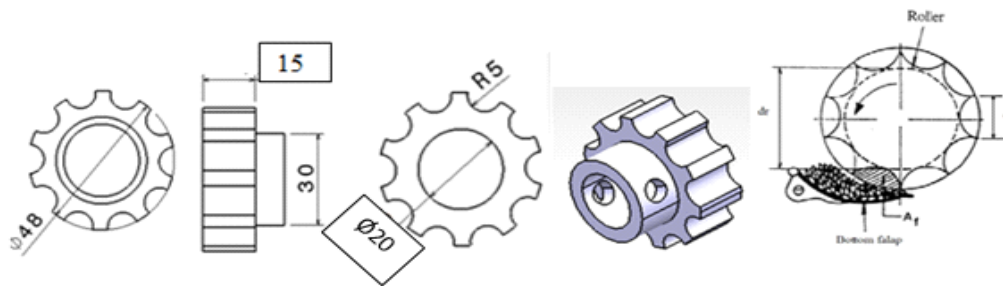

Figure 3. Schematic diagram and isometric view of fluted roller

### Adjustable furrow openers

Furrow openers were attached to the front side of frame which is used to open the soil for seed and fertilizer placement. As the furrow openers open the soil, the seeds and fertilizers come from delivery tube drops into the opened furrow. Furrow openers were fitted on the main frame of the planter with bolt and nut with provisions of adjusting the depth by moving furrow openers vertically as shown in figure 1.

### Seed tube

Seeds and fertilizer pass through delivery tube into opened furrow. The seed tube delivers the seeds and fertilizer at a desired uniform spacing into the opened furrow. Seed and fertilizer delivery tubes were provided for safe conveying of seed and fertilizer from metering unit into furrow created by furrow opener. A circular rubber hose pipe of 20 mm diameter was attached to the tube made at the lower part of the metering flute house (discharge spout).

### Hitching system

As the sowing implement was to put in the field and would have to operate parallel to the ground level by a pair of oxen, a circular wooden beam of 2800 mm length was pinned at its end by two round bar pins in the angled MS flats. The hitch was welded on the front side of

the main frame. The MS flats were drilled two holes of 8 mm diameter at 60mm, center to center distance. Three MS flats (40 x 70 mm) were welded on the tip of MS flats of length 180 mm.

### Handle and beam

The handle considered as the main component and determines the working position of the operator. The height of handle was kept little more so that pressure can be applied on the grip of handle at the applied forces and the height of handle remains within the reach of operator. The handle was made of MS flat (150 x 90 mm) was welded on main frame and 120 mm length water pipe of 45 mm diameter was welded on the middle of MS flat and 120 mm length wooden beam insert and pinned to the pipe.

### Ground wheel

The ground wheel is designed as an integral part of the seed metering mechanism connected to the seed metering device directly through shaft. The rims of the wheel were made from mild steel sheet metal of 2 mm thick and 80 mm wide. Each wheel have eight spokes made from mild steel rods with diameter of 8 mm and length of 280.5 mm, and welded to the rim and hub at the center used as bushing or shaft bearing, at equal interval as shown in figure 4. On the circumference of ground wheel, lugs made from mild steel round bar were provided to develop better traction or grip on the soil.

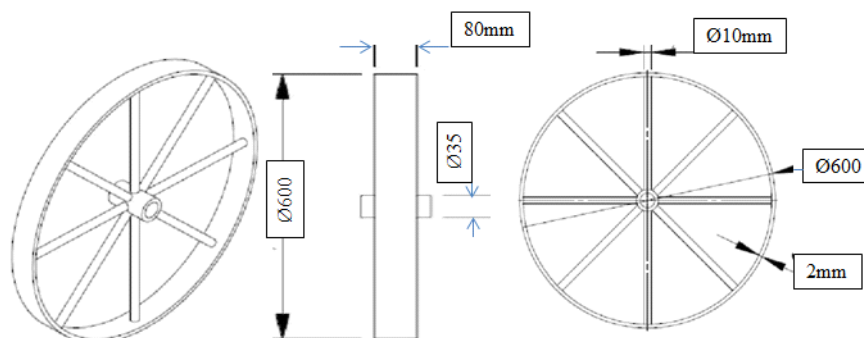

Figure 4. Isometric view of ground wheel

### Working principles of row planter

The principle of operation of the planting machine is very simple and requires only one man to operate. Seed drilling is accomplished by just pulling the planter in a prepared field. Since the metering flute roller is directly attached to the ground wheel through shaft. Ground wheel

rotates the metering flute roller also rotates, seeds and fertilizer automatically dropped into the opened furrow through the seed delivery tube.

### **Performance Test and Evaluation**

Before actual field performance test was carried out in the lab or field, the planter was tested to confirm the workability of all the functional components, to determine and check any malfunctioning parts and defects in the manufacturing.

### **Laboratory performance test**

The machine was calibrated in the laboratory to determine the rate of seed discharge and seed damage. The planter was suspended on a vice and the hopper was loaded with wheat seeds. A paint mark was made on the drive wheel to act as a reference point to count the number of revolutions when turned and a seed collecting bag was placed on the discharge tube to collect the seeds discharge and weighed. The drive wheel was rotated 10 times at constant speed. The test for percentage seed damaged was done with the machine held in a similar position of calibration.

### **Soil moisture content**

Soil moisture content on wet basis of soil was measured by oven dry method. The soil samples from test plot were taken using core sampler 80 mm diameter and 120 mm in length and a soil auger. The collected soil samples from each location were weighed initially and then kept in an oven for 24 hours at 105°C for obtaining dry weight of soil and moisture content was calculated following standard procedure as follows:-

$$M_c = \frac{W_w - W_d}{W_w} \times 100$$

Where: - MC = Moisture content of soil (%) on wet weight basis;

Ww= Weight of wet soil, g; and

Wd = Weight of dry soil, g.

### **Bulk density**

Bulk density of the soil is the oven dry mass per unit volume of the soil. It was determined by core sampler method. The core sample of soil of known volume was collected and weighed.

The bulk density was calculated by using formula:-

$$\rho = \frac{M}{V} =$$

Where,  $\rho$  = Bulk density of soil, g/cm<sup>3</sup>

M = Oven dry mass of soil contained in core sampler, g

V = Volume of core sampler, cm<sup>3</sup>

### **Width and depth of operation**

The depth of sowing was measured at different locations with the help of depth scale by putting a tip of depth scale in a furrow base and its average was taken as operating depth. The width of operation was calculated by dividing the total width of plot by the number of passes.

### **Operating speed**

The operating speed of row planter was carried out by observing the time required for traveling 40 m distance with the help of stop watch and calculated as follow:-

$$S = \frac{D}{t} * 3.6$$

Where: - S = digging speed, km / h.

D = travelling distance, m.

t = time, s.

### **Theoretical Field Capacity**

Theoretical field capacity was is the rate of field coverage of the implement, based on 100 per cent of time at the rated speed and covering 100 per cent of its rated width as follows:-

$$TFC = \frac{S * W}{10}$$

Where: - TFC = Theoretical field capacity, ha/h.

S = Operating speed, km / h.

W = Working width, m.

### **Actual field capacity**

Actual field capacity was measured by taking an area of 40 x 20 m<sup>2</sup> (i.e. 0.08 ha) and measuring the time in actual field condition. It includes turning loss, filling time and any other. There was continuously operated in the field for 0.08 ha to assess its actual coverage.

The time required for complete application was recorded and effective field capacity was calculated.

$$EFC = \frac{A}{T} * C$$

Where: -  $EFC$  = effective field capacity, ha/h.

$A$  = plot area, m<sup>2</sup>.

$T$  = time, sec.

$C$  = unit conversion factor

### **Field Efficiency**

The field efficiency is the ratio of the effective field capacity to the theoretical field capacity, the field efficiency was calculated.

$$FE = \frac{EFC}{TFC} \times 100$$

Where: -  $TFC$  = theoretical field capacity, ha/h.

$EFC$  = effective field capacity, ha/h.

$FE$  = field efficiency, %

### **Cost Analysis**

When a new technology is introduced to the farmer, they are interested to know whether the machine will be profitable to them or not. Cost analysis is very important for a new technology. Operational cost of the machine is the sum of fixed cost and operational cost of the machine. The total cost of the machine was determined by knowing the cost of the materials used for fabrication of the seed driller and fabricating cost of the machine. The following assumptions were made in determining the cost of operation of the row planter:-

i. Expected life of the machine 10 years

ii. Annual use of machine 30 days per year

Total annual use =  $30 \times 8$  h/year = 240 h/year

iii. Salvage value of the planter 10 percent of initial cost

#### **(A) Fixed cost**

It is the total cost of depreciation, interest on investment, tax, insurance and shelter. For calculating the depreciation of the machine, straight-line method was used.



**(a) Depreciation**

$$\text{Depreciation (Birr / hr)} = \frac{P - S}{L * H}$$

Where, P = purchase price (Birr),

S = Selvage value (Birr),

L = Useful life (Year)

H = Working hours per year

**(b) Annual interest @ 15 % in investment**

$$I = \frac{P + S}{2} \times \frac{i}{H}$$

Where, I = Interest Birr per hour;

i = Interest rate (a) 15%.

Shelter, Tax and Insurance, STI = 2.5% p

$$\text{Total fixed cost} = D + I + STI$$

**(B) Variable cost**

**(a) Repair and Maintenance**

Repair and maintenance cost was taken as 3.5% of initial investment

$$R \ \& \ M \ \text{cost} = \frac{3.5 \times P}{100 \times H}$$

**(b) Hire charges of pair oxen with operator**

The local custom hire charge of pair oxen with operator = 50 Birr/hr

Total variable cost = Repair and Maintenance cost + Hire charge

$$\text{Total cost of seed drilling (Birr / hr)} = \text{Fixed cost (Birr / hr)} + \text{Variabl cost (Birr / hr)}$$

$$\text{Cost of sowing operation (Birr / ha)} = \frac{\text{Total cost (Birr / hr)}}{\text{Effective field capacity (ha / hr)}}$$

## Data analysis

Simple descriptive statically analysis was used for the analysis of the mean values of data obtained from lab test and field evaluation.

## Results and Discussion

The experiments were conducted for four row animal drawn wheat crop planter in the laboratory as well as in the field. The performance of the machine was evaluated at the field of selected farmers at Hetosa district of Arsi Zone, considering seed rate, effective field capacity and field efficiency.

### Physical Properties of the Seeds

Physical properties of the seeds are important for optimizing the design parameters of the seed driller. The most popular wheat varieties of Digelu, Kekeba and Ogolcho were selected for the study. The size and shape of the seed was considered to relevant to the design of cell size on its periphery of metering flute roller and seed hopper. The slope of the hopper was selected on the basis of angle of repose of the seed. Their observed physical properties were presented in table 1.

The mean length (L), width (W), thickness (T), size, sphericity, thousand grain mass (TGM), angle of repose (AR) and bulk density (B.D) of selected wheat variety were determined and ranges from 5.49 to 6.12mm, 3.21 to 3.49 mm, 2.67 to 2.81 mm, 2.60 to 3.90 mm, 62.62 to 65.81%, 31.83 to 34.76 gm, 25.44 to 26.97 degree and 781.54 to 801.91 kg/m<sup>3</sup> respectively.

Table 1. Physical properties of digalu, kakeba and ogolcho wheat seeds varieties.

Physical properties	Samples size	Digalu	Kekeba	Ogolcho	Unit
Length ( L )	30	5.49±1.23	6.12±0.58	6.03±0.29	Mm
Width ( W ),	30	3.24±1.23	3.49±0.45	3.21±0.25	Mm
Thickness ( T )	30	2.67±0.89	2.81±0.45	2.8±0.19	Mm
Size	30	3.60±0.350	3.9±0.32	2.77±3.70	Mm
Sphericity	30	65.81±6.14	64.79±2.87	62.62±2.81	%
TGW	5	31.83±3.14	34±0.44	34.76±0.47	Gm
Angle of repose	5	25.86±0.84	25.44±0.74	26.97±0.94	Degree
Bulk density	5	791.15±2.94	781.54±2.48	801.91±2.48	kg/m <sup>3</sup>

## Mechanical damage to seed by metering mechanism

The mechanical seed damage is defined as injury to seeds, partially or completely by the seed metering of row planter. During the laboratory test of the row planter, drive wheel was rotated at animal walking speed. The observations of the mechanically damaged seeds of 1000g seeds were used for the testing; the variation of the damage seeds was found 0.06 to 0.12g seeds for different replications. The average percentage of the mechanically damaged seeds for Ogolcho wheat seed variety was found 0.0082%. Abiy Solomon (2017) found mean percent seed damaged for a Kekeba wheat variety seed was found to be 0.0088%. However, the internal damage of seeds was measured by germination test was found 98.78 % germination rate which is greater than that of predicted by seed supplier (98.7 %).

Table: 2. Mechanical damage to wheat seeds by seed drill

1. Table 1

Sr.no	Crop variety	Total weight of sample (g)	weight of broken seeds(g)	Percentage of damaged seeds %
1	Ogolcho	1000	0.12	0.012
2	Ogolcho	1000	0.08	0.008
3	Ogolcho	1000	0.10	0.004
4	Ogolcho	1000	0.11	0.011
5	Ogolcho	1000	0.06	0.006
Average			0.082	0.0082

## Effect of flap position on seed rates

Seed rate calibration is necessary to calibrate the planter before putting it in actual use to find the desired seed rate. It has been done to get the predetermined seed rate of the planter. Ogolcho variety was used for laboratory calibration by varying the flap position at upper, middle and lower (fully opened). A plastic bag was attached to each seed tubes to collect the seeds. The average seeds collected in the laboratory were observed as, 118.07, 127.07 and 141.26 kg/ha for upper, middle and lower as shown in table 3. Data revealed that with middle

flap position gave nearest values of seed rate in the range of 126.85 – 127.27 kg/ha. Average value of 127.07 kg/ha was obtained which is nearest to the recommended seed rate of 125 kg/ha of wheat.

Table 3. Mass of seeds collected from each furrow opener per 100 m length

Flap position	Replication	F1	F2	F3	F4	Total Seed Collected (gm)	Seed Rate (kg/ha)
Upper	1	235.34	239.19	230.30	234.71	939.54	117.44
	2	239.80	238.67	240.47	232.50	951.44	118.93
	3	235.80	231.10	241.33	234.67	942.90	117.86
Average		236.98	236.32	237.36	233.96	944.62	118.07
Middle	1	253.80	250.77	254.97	255.27	1014.81	126.85
	2	252.33	258.23	251.43	254.70	1016.69	127.08
	3	254.20	252.93	257.33	253.70	1018.16	127.27
Average		253.44	253.97	254.57	254.55	1016.55	127.07
Lower	1	278.33	283.3	280.13	289.43	1131.19	141.39
	2	277.62	288.07	283.78	285.45	1134.92	141.86
	3	283.66	272.33	285.29	282.97	1124.25	140.53
Average		279.87	281.23	283.06	285.95	1130.12	141.26

### Effect of Hopper Filling Level on Seed Rates

Table 4 shows the effect of hoper filling level on seed rate variations. It was observed that the entire samples collected for each hopper filling (Full, 3/4th and half) at middle flap position was nearly the same and there was little deviation among the samples.

Table 4. Mean mass of seeds collect for different hopper filling level at middle flap position

Observation	Seed rate (kg/ha)		
	Halve	Three fourth	Full
1	128.2	128.08	127.93
2	127.72	126.9	127.16
3	127.45	127.88	129.15
4	126.64	128.63	126.5
Mean	127.5	127.87	127.68

### Field test

The developed row planter was tested on farmers' wheat fields for its actual performances on plot of (20 m x 40 m) at Hetosa district. Ogolcho wheat variety was used for the study.

### Moisture Content and Bulk Density of Soil

Five soil samples were taken randomly at different location of the field at 15 cm depth from the surface of soil before operation of planter using core sampler of 8 cm diameter and 8 cm height. Average values of moisture content and bulk density were observed as 19.25% on dry basis and 15.49% on wet basis and 1.45 g/cm<sup>3</sup> respectively for experimental field as presented in table 5.

Table 5. Moisture content and bulk density of soil

<i>Observation</i>	<i>Weight of a soil (g)</i>	<i>Weight of oven dried soil (g)</i>	<i>Moisture Content (%)</i>		<i>Bulk Density (g/cm<sup>3</sup>)</i>
			<i>%Wb</i>	<i>%Db</i>	
<i>1</i>	<i>689</i>	<i>576</i>	<i>16.4</i>	<i>19.62</i>	<i>1.43</i>
<i>2</i>	<i>700</i>	<i>585</i>	<i>16.43</i>	<i>19.66</i>	<i>1.45</i>
<i>3</i>	<i>703</i>	<i>592</i>	<i>15.88</i>	<i>18.75</i>	<i>1.47</i>
<i>4</i>	<i>694</i>	<i>579</i>	<i>16.57</i>	<i>19.86</i>	<i>1.44</i>
<i>5</i>	<i>697</i>	<i>589</i>	<i>15.49</i>	<i>18.34</i>	<i>1.46</i>
<i>Average</i>	<i>696.6</i>	<i>584.2</i>	<i>16.15</i>	<i>19.25</i>	<i>1.45</i>
<i>S.D</i>	<i>5.41</i>	<i>6.69</i>	<i>0.45</i>	<i>0.66</i>	<i>0.02</i>

### Effective field capacity and Field efficiency of the row planter

The field capacity and field efficiency was calculated for planter using standard methodology described earlier and results are presented in table 6. The theoretical field capacity was determined as 0.137 ha/h, whereas the actual field capacity of planter was found to be 0.112 ha/h. From the actual and theoretical field capacity the field efficiency of the four row animal drawn row planter was found to be 81.95%. Generally, this shows that the row planter can sow a hectare of land within 8 to 9 working hours depending on the speed of operations.

Table 6: Field performance test results

<i>No. plot</i>	<i>Operating Speed (km/h)</i>	<i>TFC (ha/h)</i>	<i>EFC (ha/h)</i>	<i>Field efficiency (%)</i>
<i>1</i>	<i>1.71</i>	<i>0.137</i>	<i>0.111</i>	<i>81.02</i>
<i>2</i>	<i>1.73</i>	<i>0.138</i>	<i>0.114</i>	<i>82.61</i>
<i>3</i>	<i>1.69</i>	<i>0.135</i>	<i>0.111</i>	<i>82.22</i>
<i>Average</i>	<i>1.71</i>	<i>0.137</i>	<i>0.112</i>	<i>81.95</i>

## Plant population count

Plant population count was carried out in the field after twenty days of seeding; number of seeds germinated per 1m<sup>2</sup> area was counted as shown in table 7. However, there was some deviation of seeds emergence at the field as compared to the recommended seed emergence, these variations might be due to environmental factors.

Table 7: Seed germination potential obtained at field test

Replication	Field germination count Per 1m <sup>2</sup>		
	Expected	Counted	% Germinated
1	320	310	96.88
2	320	316	98.75
3	320	315	98.44
4	320	312	97.50
5	320	318	99.37
Average	320	<b>314.2</b>	<b>98.19</b>

## Cost Analysis

The cost of operation of the machine per hour as well as per ha is presented in table 8. The annual use of the row planter was taken only 240 hr/year. The unit cost of the developed four row animal drawn row planter was determined by calculating the cost of different components and their fabrication cost. The estimated cost of the developed animal drawn row planter was determined as 5893.3 Birr. The fixed cost and variable costs for row planter seed driller are presented in table 8. In this study, manual drilling required 12 man-days to seed drill one hectare of wheat field. Considering 400Birr per day hire of pair of oxen with operator and 150birr per day for manual seed and fertilizer drilling wage, hence 3400 birr/ha was required for manual seed drilling, whereas 832.23 birr/ha was calculated for row planter (table 8).

Net savings per hectare area 2,567.77Birr/ha could be saved as compared row planter against manual seed drilling. This net saving comes because of higher field capacity of row planter than manual seed drilling.

Table 8: Operational cost of row planter and hand drilling

Cost of row planter	5,893.3Birr
Fixed cost	
Deprecation	2.21 Birr/hr
Interest on investment/h @ 15% per hour	2.03 Birr/hr
Tax, Insurance and Shelter (@ 2.5% of initial cost per hour	0.61
Total fixed cost/hour	4.85 Birr/hr
Variable/Operational cost	
Maintenance cost (@ 3.5% of initial cost per hour)	0.86 Birr/hr
Hire of oxen with operator per hour	50
Wage of two assistance operator per hour	37.50 Birr/hr
Total operation cost per hour	88.36 Birr/hr
Total cost /hr (Fixed cost + operational cost)	93.21 Birr/hr
Operational cost/ha	832.23 Birr/ha

### Conclusions and Recommendations

On the basis of the findings of overall performance of the redesigned row planter was found best as compared to previous row planters and sowing behind the plough. Modification made in the seed cum fertilizer applicator resulted proper dropping of seeds in furrows with satisfactory seed placement with covering by soil. In general, the performance evaluations made indicated that the planter can be used successfully and the cost of the developed row planter is within the buying capacity of the small farmers. Hence, it can be concluded that the developed row planter overall performance is satisfactory and recommended for large demonstration.

### Reference

- Abiy Solomon, 2017. Design, Fabrication and Performance Evaluation of Two-Wheel Tractor Drawn Six Row Wheat Seed Drill. Unpublished MSc Thesis in Agricultural Machinery Engineering. Adama Science and Technology University, Ethiopia.
- Central Statistical Agency (CSA), 2013. Revised Report on the 2012 / 2013 Private peasant holdings, meher season, area and production of major crops Survey. Statistical Bulletin 532. Addis Ababa: The Federal Democratic Republic of Ethiopia.
- of canola agronomic and varietal development research. Council of Canada. 10: 8-10.
- FAO, 2009. How to feed the world in 2050. ([www.fao.org/fileadmin/templates/wsfs/docs/expert paper /How to feed the World in 2050](http://www.fao.org/fileadmin/templates/wsfs/docs/expert_paper/How_to_feed_the_World_in_2050.pdf)).
- Kepner, R.A., Bainer, R., Barger, E.L., 1978. Principles of Farm Machinery, 3rd edition. Inc. AVI Publishing Company, Westport, USA.
- Navneet Kumar Dhruwe (2016): Development of light weight five row animal drawn multi crop planter. Agricultural Engineering, India, unpublished.
- Olaoye, J.O. and Bolufawi, S.J., 2001. Design, fabrication and performance of multipurpose row planting machine. J. Sustain. Agric. Environ, 3(1): 7-20.
- RNAM (Regional Network for Agricultural Machinery), (1991). Agricultural Machinery Design and Data Handbook (Seeders and Planters). Economic and social for Asia and Pacific: 23-71.
- Sharma, D. N. and Mukesh S (2010): Farm machinery design principles and problems, second edition. Jain brothers.

## **Development and Evaluation of Solar Powered Pesticide Sprayer for Large Fruit Trees**

Jemal Nur\*, Heykel Jemal<sup>2</sup> and Bayissa Tarecha\*<sup>2</sup>

<sup>\*,2</sup> *Oromia Agricultural Research Institute, Fedis Agricultural Research Centre, Harar, Ethiopia*

<sup>2</sup> *Harar Polyphonic College, Automotive Department, Harar, Ethiopia*

\*Corresponding Author Email: [jeminur@gmail.com](mailto:jeminur@gmail.com)

### **Abstracts**

*In agriculture sector, spraying of pesticides is an important task to protect the crops from insects for obtaining high yield. However, farmers have been mainly using traditional conventional techniques like hand operated knapsack. If hand operated spray systems are used, the labor productivity decreases and the efficiency will be low, as well as chemical hazardous was a main problem. The use of solar energy system and faring pesticides contacts from operator is an alternate solution for these limitations. Hence, a solar powered agricultural pesticide sprayer was developed and evaluated for fruit tree like mangoes, avocado, and papaya. The system was by considering parameters like desired spraying*



*capacity, low weight, low cost, user-friendly nature, high operating time and for faster coverage of area as compared with that of old. The machine has capacity of 0.25 ha/hrs. Actual area coverage and discharging rate of 1.32lit/min, as well as the efficiency the machine was 79.4 % horizontal and vertical distance of the sprayer was 11 m and 9 m length respectively these values were coincided with average fruit tree of the study area. In addition to this the pumping efficiency of the DC motor was 71.7 % and the battery life was six (6)hr which take five (5) hr to full charging, but charging was possible simultaneously during operation. Among tested hose types six diameters at nine (9) m had good booming uniformity and droplet size which was relatively agreed with recommended values.*

**Key points:** *Solar Sprayer, Battery, DC Pump, Nozzle, Solar Panel and Hose.*

### **Introduction**

Agriculture is a profession of many tedious processes and practices, one of which is spraying of pesticides in the farm fields. Sprayers are mechanical devices that are specifically designed to spray liquids quickly and easily. Spraying of pesticides is an important task in agriculture for protecting the crops from insects. Farmers mainly use hand operated or fuel operated spray pump for this task. Backpack sprayers are fitted with a harness so the sprayers can be carried on the operator back. Tank capacity may be large as 20 liters. A hand lever is continuously operated for to maintain the pressure which makes the backpack sprayers output more uniform than that of a handheld sprayers Basic low cost backpack sprayer will generate only low pressure and lack feature such as high-pressure pumps, pressure adjustment control (regulator) and pressure gauge found on commercial grade units (Joshua *et al.*, 2010).

The engine operated sprayers typically produce more consistent sprayer's outputs, cover the sprays swath more uniformly, operate at constant speed and results in much more uniform coverage than the hand spraying. Motorized sprayers are also capable of higher pressure spray where required to provide a better coverage. There are many other types of hand operated sprayer that are not widely used throughout the agriculture. Some may be used wide extensively for the productions of specific commodities.

The High pressure sprayer is often called as hydraulic sprayers. They usually operate with a dilute mixture and at different pressure from two hundred and fifty up to several hundred psi limits. The design of high pressure sprayer is similar to that of low pressure sprayer; the only difference is that the component has to withstand high pressure. When fitted with boom they can do any work done by the suitable low pressure boom sprayers. These can also be fitted with handgun. The handgun are used for spraying shade tree and ornamental, livestock,

orchards, building, unwanted brush, rights-of-way, commercial crop etc., reduce drudgery, hazardous of chemical, Riley and Siemsen Ne. , (2003).

In this paper a solar operated was aimed to develop. A sprayer of this type was a great way to use solar energy. Solar based semi-automatic pesticides sprayer are the ultimate cost effective solution at the locations where spraying is difficult. This semi-automatic solar based pesticide sprayer system uses solar energy as source. Solar energy was first used to charge a storage battery. The solar energy stored in the battery was utilized to operate motor which functions as pump.

The prominent aim of this project is to fulfill the tasks of hand spraying, using non-conventional energy sources. Thus solar operated spray pump was help the farmers of those remote areas of east Hararghe zone where sun intensity available easily. They performed their regular work as well as saves labour up to large extent. At the same time they reduced environment pollution. The solar powered agricultural pesticide sprayer was fabricated according to the design parameters. The prototype is field tested according to the standard conditions. Our sprayer is of low cost and is easy to move in the field. After experimentation, it is observed that it reduces the user fatigue and improves the quality of spraying pesticides. The proposed system of Pesticide Sprayer which was expected to achieve better results compared to the oldest methods with using human assistance. This would be semi-automatic that would be powered by solar energy and reduce drudgery, hazardous of chemical by faring tip of the nozzle to protect the farmers and cultivators from harmful pesticides and chemicals. So the objective the study was to develop a solar powered pesticide spray for the fruit trees.

### **Materials and Methods**

The machines was constructed in FARC workshop, and evaluated on farm land of Babile and Fadis on the papaya, avocado and mango tree, which is located in East Hararghe zone of Oromia National Regional State of 1885 m above sea level in eastern Ethiopia and 522 km far from Finfinne. The district is lying between 09°18'9''N latitudes and 42°07'3'' longitudes.

Table 1. Description of solar powered sprayer material and specification

Sr.No	Description	Specification
1	Tank	PVC,15-20 Lit

2	Solar panel	20W PV solar panel:- Dimension: 540x350x25 mm, Weight :1 kg, Max voltage:17V, Max current: 1.18 A, Tolerance: ± 5%
3	Charge controller	Capacity 12v,5A
4	Battery	Sealed lead acid battery:- capacity: 12v,9Ah.dimension: 15*9*6cm, weight:2.5 kg, max initial current 2.4A, cycle use :14.5-14.9 v
5	Motor	Brushless DC motor Capacity :12 V, 1.2 A RPM :0-6000
6	Hose	Diameter: 6,8 and 10 mm diameter types 1/4
7	Metal parts	Wheel chair wheel, angle iron, square pipe, electric wire 1.8, metal pipes
8	Switch	push button type switch
9	Hardener	Epoxy

### **Solar panel**

A solar panel (also solar module, photovoltaic module or photovoltaic panel) is a packaged, connected assembly of photovoltaic cells. The solar panel can be used as a component of a larger photovoltaic system to generate and supply electricity in commercial and residential applications.. A photovoltaic system typically includes an array of solar panels, an inverter, and sometimes a battery and or solar tracker and interconnection wiring. Dimension of the panel was 540\*350\*25 mm.

**DC motor:** DC motor is used to lift the pesticide from tank to delivers sprayer nozzle, The DC pump is selected because of the advantages such as less in noise, longer in life, maintenance free.12 V DC motor

**Battery:** An electric battery is a device consisting of one or more electrochemical cells with external connections provided to power electrical devices. When a battery is supplying electric power, its positive terminal is the cathode and its negative terminal is the anode.

**Tank:** Storage tanks are containers that hold liquids used for the short-term storage of fluids. The term can be used for reservoirs. Storage tanks are available in rectangular shapes was selected.

**Nozzle:** A nozzle is a device designed to control the direction or characteristics of a fluid flow (especially to increase velocity) as it exits (or enters) an enclosed hose. A nozzle is often a pipe or tube of varying cross sectional area and it can be used to direct or modify the flow of a fluid (liquid or gas).

### **Solar sprayer carrier Frame**

The frame was used to support all the body and constructed from angle iron, square pipe and wheel. The main functions of a frame are: To support the tank components and all accessory body & to deal with static and dynamic loads, without undue deflection or distortion.

### Description of machines

In the assembly process the base structure (Carrier) was made from square pipe and angle iron, the required parts were fixed in the predetermined positions and the connections were made. Solar panel was placed in such a way that it can absorb the sunlight and this solar panel is connected to the controller and to the battery, so that we can charge the battery and from battery is connected to the DC motor, with the help of this the pump which was attached at the bottom of tank sucks the liquid from tank to flow through the hose it comes out of nozzle and pesticide is applied this in is the assembly process. The 'ON' and 'OFF' of motor is controlled with handle attached to spray gun as push button type switch.

**Vertical arm:** It was constructed from 40 mm square pipes of 1.50 m height and fixed with 1 inch of 0.30 height hollow shaft at the top again solar frame was attached at the middle with angle of  $90^\circ$



**Fig.1** vertical arm

**Horizontal arm:** It was assembled from 30, 25 and 20 mm square pipes of 4, 3, and 2.5 m length respectively. At 2 m from handlebar the jointer was hinged from hollow shaft of ½ inch diameter and 0.25 meter length to insert into 1 inch hollow shaft at the top of vertical arm. The horizontal arm was guided by operator at handle bar to carry the hose internally and rotate at 360°

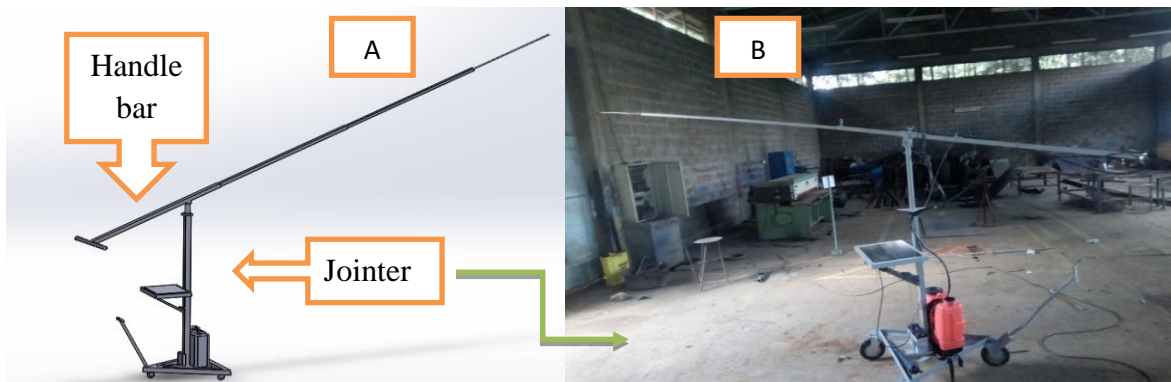

Figure 2. A- 3D frame design; B - fully Assembled prototype of solar powered sprayers

**Block diagram:** The block diagram of solar sprayer system was shown in order below,

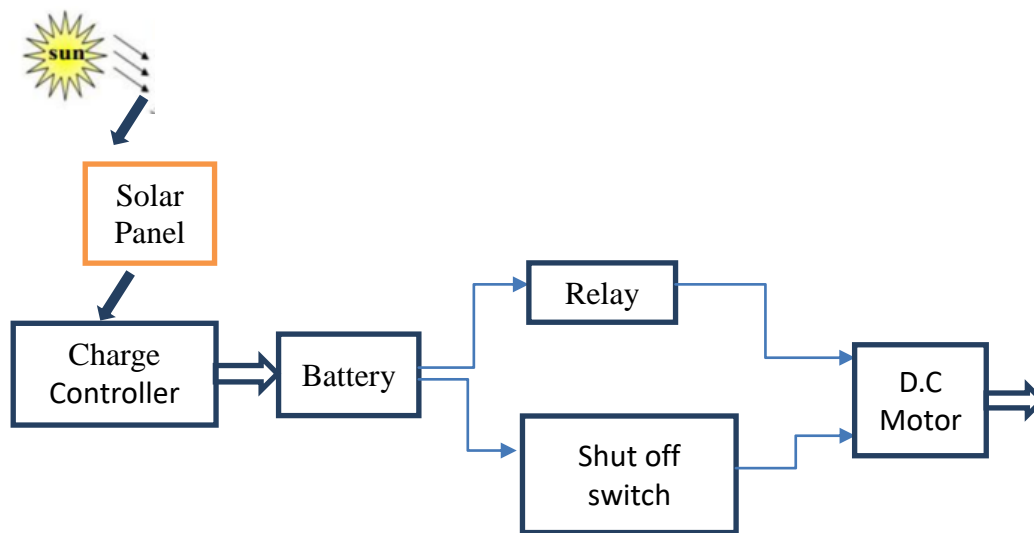

Figure 3. Flow chart of operation mechanism solar powered sprayer

### Experimental design and Statistical Analysis

The experiment was arranged in Randomized Complete Block Design (RCBD). Diameter and length hose were factors. Each treatment was replicated three times, accordingly the experimental treatment were 27 (twenty seven) total treatment combination. The height of the delivery hose containing nozzle is in the range of 3 (three) m, 6 (six) m and 9 (nine) m and diameter of 6 (six) mm, 8 (eight) mm and 10 (ten) mm. All measured variables were subjected to Genstat 15<sup>th</sup> edition software for analysis of variance. When the treatment effects were

found significant, the mean difference was tested using least significant difference at 5% level of probability.

Table .1 Treatments of the Experiment

Treatment	Hose diameter in (mm)	Hose length in (m)	Treatment combination
T <sub>1</sub>	6	3	Six diameter at three meter length
T <sub>2</sub>		6	Six diameter at six meter length
T <sub>3</sub>		9	Six diameter at nine meter length
T <sub>4</sub>	8	3	Eight diameter at three meter length
T <sub>5</sub>		6	Eight diameter at six meter length
T <sub>6</sub>		9	Eight diameter at nine meter length
T <sub>7</sub>	10	3	Ten diameter at three meter length
T <sub>8</sub>		6	Ten diameter at six meter length
T <sub>9</sub>		9	Ten diameter at nine meter length

### Data collected

Data collected during testing the solar sprayer on fruit tree of different height were Parameters like, Droplet size, Boom uniformity, Area coverage, Vertical height, discharging rate of fluids gathered as proposed. In addition to this data of solar system battery discharging rate, charging time, solar capacity, and Pumping efficiency were collected likely. All observations were recorded as means of three replications, were statistically analyzed to determine the significant difference.

### Machine performance

#### *Field capacity*

For calculating actual field capacity, the consumed time for real work and that lost for other activities such as cut off, filling of tank were taken into consideration. The time required for actual operation and time lost measured by stopwatch. The time lost for recharging was deleted because usually filling up before starting test can make recharging unnecessary for specially large field, also time for fixing machine trouble and nozzle was not taken into consideration as it varies widely to varies factors and its inclusion in time factor sometime unreasonably lower the actual field capacity.

$$\text{Actual field capacity} = \frac{\text{Actual area covered (ha)}}{\text{Total time required to covered area (hr)}}$$

$$\text{Theoretical field capacity} = \frac{\text{Theoretical width (m)} \times \text{Speed (km/h)}}{10}$$

### **Power Conversion Efficiency**

The Panel of the solar cell power conversion efficiency can be calculated by using the relation (Joshua *et al.* 2010)

$$\text{(Power conversion efficiency)} \eta = \frac{P_{max}}{P_{in}} = \frac{\text{output power}}{\text{input power}}$$

Equation of power calculation, (International Journal of Latest Engineering Research and Applications (Soothaand Gupta, 1991).

$$\text{Power} = \text{Voltage} \times \text{current}$$

$$B_t = \frac{\text{(Power stored in battery)}}{\text{Power Consumed by motor (pump)}}$$

### **Pumping efficiency**

This gives the measure how effectively the motor utilize the power supplied by the battery in delivering with constant pressure to the hose pipe.

$$\text{Pumping efficiency} = \frac{\text{power required to deliver liquid}}{\text{power supplied by the solar panel}} * 100$$

### **Assumptions**

The coverage area (Fruit trees canopy) is in the form of sector of a spherical shape whose path is controlled by operator.

## **Results and Discussion**

The result observed was indicated in calculation and tabulated outline form

### **Solar panel**

Voltage at maximum power  $V = 17V$

Current at maximum power  $I = 1.18A$

$$\begin{aligned} P &= V * I \\ &= 17 * 1.18A \\ &= \underline{20.06Wh} \end{aligned}$$

where, "P" was Power generated by solar panel

### **Battery**

12v, 9Ah current were taken from voltmeter reading

$$\begin{aligned} \text{Power} &= V \times I \\ &= 12v \times 9Ah = \underline{108Wh} \end{aligned}$$

#### **A. Battery charging time**

Time required charging the battery

$$T = \frac{108whrs}{20w} = \underline{5.4hrs}$$

Note- charging time varies with intensity of sun radiations at different rate.

#### **B. Battery discharging time**

Voltage = 12 V

Current = 1.5 Amp

We know the equation of the backup battery time of sprayer

$$\begin{aligned} B_t &= \frac{\text{(Power stored in battery)}}{\text{Power Consumed by motor (pump)}} \\ &= \frac{108Wh}{1.5Am * 12v} = \underline{6hrs} \end{aligned}$$

Where  $B_t$  is time of battery life. Therefore the battery time of spray was (six) 6 hrs.

### **Pumping efficiency**

Where power required to deliver liquid was 14.4 W and Power supplied by solar panel 20.07 W pumping efficiency was found to be 71.74 %. To provide the required energy to the system 20 W solar panels and 12 V DC motor was selected, so that the produced energy was stored in the battery then used by DC motor. To continuous supply of power to the spraying system,



battery bank of (12v, 9Ah) was used. Indicated the battery was continuously charging from the solar panel as there was a demand to operate by pumps. The mean values result of field performance over different fruit tree height were tabulated in the following table 3 below

Table 3. Mean values of performance test

Hose diameter (mm)	Treatment	Droplet size (mm)	Boom/Uniformity (inch)	Horizontal Distance (m)	Vertical Distance (m)	Area Coverage (ha)	Discharge rate lit/min
Smallest 6 (Six)	T <sub>1</sub>	0.816a	0.53a	4.84b	3.753a	1.19c	2.013ab
	T <sub>2</sub>	0.693a	0.997ab	7.537c	6.903b	0.8133bc	1.78ab
	T <sub>3</sub>	0.927a	1.43ab	10.015d	9.783c	0.3567ab	1.32a
Medium 8 (Eight)	T <sub>4</sub>	1.55a	2.263abc	4.507ab	3.967a	0.1667a	2.8c
	T <sub>5</sub>	0.827a	1.913ab	7.737c	6.93b	0.37ab	1.877ab
	T <sub>6</sub>	0.787a	2.54bc	9.98d	10.223c	0.36ab	2.073b
Largest 10 (Ten)	T <sub>7</sub>	1.53ab	2.093abc	4.147a	3.68a	0.2633ab	2.83c
	T <sub>8</sub>	1.6ab	2.26abc	7.37c	7.477b	0.3867ab	2.037b
	T <sub>9</sub>	2.283b	3.737c	9.917d	9.757c	0.1233a	1.527ab
CV (%)		30.7	46.5	5	7	68.2	18.3
L.S.D (%)		0.818	1.59	0.6436	0.8422	0.5289	0.6423

(FAO, 1994 Testing and evaluation of agricultural machinery and equipment)

### Droplet size

ANOVA indicated that droplet size of the sprayed fluid was significantly different among three diameter ( $p < 0.05$ ) even if at equal length of hose. This shown that the diameter of the hose affect the droplet size which leads to miss match with that of recommended size. But, for six (6) mm diameter the droplet size was uniform at all three length under test, therefore without any droplet disturbance for the largest length was observed, as well as this shown us the battery and motor pump capacity to fit. Eight and Ten diameter hose droplet size vary with respect to length again it was beyond the motor pumping capacity, since resistance is increase with increasing length and diameter of hose so that the pressure developed by motor was less than that of opposite resistance.

By comparing with medium and largest diameter the lowest mean values of droplet size was in smallest diameter 0.816, 0.693 and 0.927 respectively this was preferable than rest. Large droplets have the advantage of being less susceptible to spray drift, but require more water per unit of land covered. Due to static electricity, small droplets are able to maximize contact with a target organism, but very still wind conditions are required ([www.ijirst.org](http://www.ijirst.org)).

### Boom Uniformity

As ANOVA indicated that the lowest mean values or the gap between the droplet of spray was recorded from (smallest) six diameter of hose, which shown that more uniformity spray pattern during testing was occurred at smallest diameter, which among largest, medium, and smallest diameter the smallest one was relatively agree with the result of 255 and 588 micro meter knapsack sprayer booming pattern recorded at laboratory, (Foques and Nuyttens, 2011a), the accuracy of measurement was affected by natural factor like wind and sun so that droplet size of the drop expanded more than nature of boom before measuring by calliper,

### **Horizontal and Vertical distance**

Both distance obtained was indirectly proportional to the spraying capacity of the sprayer so that the optimum point which keep all parameter at expected level was 9 m and 11 m vertical and horizontal respectively.

### **Area coverage**

The highest mean values of area coverage was recorded under smallest diameter at three meter length this was due to high pumping capacity of motor at shorter distance as the length of pipes was increase the booming capacity of the nozzle also decrease as a result of pressure loss through tank, hose and nozzle. Therefore average values was taken keeps all parameters at expected level of height of tree, area, motor capacity etc., so that smallest diameter (six diameter) at nine (9) meter length was agreed values

### **Discharge Rate**

At fully charged battery the sprayer was pump the fluid of 5 litre in 6.18 min by recording with stop watch averagely, from the obtained result the motor discharge capacity was 1.32lit/min

### **Performance evaluation of solar sprayer**

Boom length from nozzle was 0.9 m to 1.5 m was observed by using 6mm diameter hose at 9 m (nine meter) m and 11.5 m vertical and horizontal distance respectively. A hose carrier or slider was fabricated by using square pipe of (15 & 30)×3×6000 mm size of totally 8m (eight meter) height attached to the centre of the stand frame. The solar powered spray pump system worked for 6 hrs. The battery had 12.87 V indicating it had not been completely discharged

since continuously depend on whether condition. The time taken to cover 1 acre of land by our system is 3 hrs.

The developed sprayer boom was tested in actual field on fruits Trees with average height of 10m. The sprayer was evaluated in local fruits tree for actual field capacity, theoretical field capacity, solar consummation, etc. Result of performance evaluation trial of solar sprayer on avocado, papaya and mango fruits trees.

### **Field efficiency**

Field efficiency is the ratio of actual field capacity to the theoretical field capacity; field efficiency is expressed in.

$$\text{Actual field capacity} = \frac{\text{Actual area covered (ha)}}{\text{Total time required to covered area (hr)}}$$

Assume that area of the fruit tree canopy was spherical shape of average radius of 5m.

$$A = 4\pi r^2 = 314\text{m}^2 = 0.0314\text{ha} \text{ to cover this area it took } 7.6\text{min} = 0.125\text{hr}$$

$$= \frac{0.0314\text{ha}}{0.125\text{hr}} = 0.25 \text{ ha/hr}$$

$$\text{Theoretical field capacity} = \frac{\text{Theoretical width (m)} \times \text{Speed (km/h)}}{10}$$

$$= \frac{1.9 \text{ m} \times 1.66 \text{ (km/h)}}{10} = 0.315\text{ha/hr}$$

$$\text{Field efficiency} = \frac{\text{Actual field capacity}}{\text{Theoretical field capacity}} * 100$$

$$= \frac{0.25}{0.315} * 100 = \underline{79.4\%}$$

### **Conclusion and Recommendation**

As observed from the above result the solar powered sprayer was best alternative in order to alleviate the problem during spraying on the operator of oldest type, since the spraying head was 10 (Ten) m and 9.8 m horizontal and vertical far away respectively with good area coverage and boom uniformity. The optimum level of hose diameter was 6 (six) mm at where

area coverage, discharge capacity of battery and pump, uniformity, droplet size was appropriate. Based on the performance evaluation results obtained the performance of the machines was affected by hose diameter and length of hose, so that the minimum droplet size and good uniformity can be achieved under six diameter was recommended hose dimensions.

In general, the proposed system was fulfilled the farmers' need for spraying the pesticide in farm fields for fruit trees easily, we highly recommend to use this technology for any use for desired purpose, since it is more effective. For further research, dry bamboo stem will replace in place of square pipe as hose carrier to reach the maximum height of any kind of fruit tree in order to decrease the load and cost of material. It's possible to use this sprayer for other stem grain like sorghum and maize to spray any fluid since it rotates in multidirectional. The main consideration of this solar was leakage from tanks, pipes or nozzles due to high pumping pressure of the motor.

## Reference

- Becky Riley and Lauren Siemen Newman 2003. On the frontline: Health hazard posed to pesticide applicators, restoring healthy school landscapes, pp. 18-24
- Foqué D. & Nuyttens D. (2011a) Nozzle Type and Spray Angle Effects On Spray Deposition in Ivy Pot Plants. *Pest Management Science*. 67: 199–208
- R. Joshua, V. Vasu and P. Vincent. 2010. Solar Sprayer - An Agriculture Implement *International Journal of Sustainable Agriculture* 2 (1): 16-19, 2010,
- Sootha, G.D. and S.K. Gupta, 1991. Jugal Kishor (Ed.) Solar Energy Centre. Proceedings of the Workshop on Technology Transfer
- [www.ijirst.org](http://www.ijirst.org). Agricultural Fertilizers and Pesticides Sprayers - A Review (*IJIRST –International Journal for Innovative Research in Science & Technology*| Volume 1 | Issue 11 | April 2015 ISSN (online): 2349-6010 by Nitish Das; Namit Maske, Vinayak Khawas, S. K. Chaudhary and R. D. Dhete

## Performance Evaluation of Jima Drum Replaceable Multi-Crop Thresher for Wheat and Barley Threshing

Tekalign Bedada\*, Milkessa Alemu, Teshome Urghe

*Oromia Agricultural Research Institute, Fedis Agricultural Research Center, Harar, Ethiopia.*

\*Corresponding author Email: [bedada.tekalign@yahoo.com](mailto:bedada.tekalign@yahoo.com)

## **Abstract**

*The Jima drum replaceable multi-crop thresher which was produced at Jima agricultural engineering research center was evaluated in Fedis agricultural research center for threshing performance of the crops wheat and barley. During evaluation the basic variables that given-attention were feed rates (kg/min), machine speeds (rpm) and crop types. The performance evaluation was done for wheat and barley crops at their average temperature 21°C, average moisture content 12.25 % and at constant inlet 20mm, central-beneath 50mm and out-let 20mm drum-concave clearance of the machine. The results obtained were threshing efficiency varied in the range of 99.03% to 99.82% for wheat crop and 97.10% to 100% for barley. Its throughput capacity was 2.25-2.5qt/hr for wheat and 2.2-2.86 qt/h for barley.*

**Keywords:** *Thresher, performance evaluation, variables, efficiency, output capacity.*

## **Introduction**

The term threshing can be defined as the process of detaching grains from the heads or from the plants. Threshing separates grains from panicles, cobs and pods. Threshing or detaching the kernels from the ears or pods is accomplished by combination of impact and rubbing action. While the conventional tangential threshing unit threshes mostly by impact other threshing devices like rotary threshing units act more by rubbing [1].

A Threshing is on the principle that when; some input or pounding is given on crops the grains is separate from panicles, cobs and pods. The crop mass passes through a gap between drum and concave wearing or rubbing action takes place this separates grain form panicles. Thus rupture of the bond between the grain ears is due to the factor, like: impact of beaters or spikes over grain and wearing or rubbing action; the strength of bond between the grain and panicles depends up on:

- 1) Type of crop
- 2) Variety of crop
- 3) Ripening phase of crop and
- 4) Moisture content of grain

In Ethiopia as well as in the Oromia region most of threshing operation was done manually (by hand). Few threshing operations are done by using combine harvesters and some engine driven threshers. For threshing of wheat and barley crop Asela wheat and barley thresher is utilized in limited areas. In East Harerghe Zone utilization of wheat and barley thresher is almost nothing. Due to that farmers are lost their time, money and energy for traditional threshing.

So, the objective of this study was to do the performance evaluation of this machine and if there was drawback plus inconveniences for threshing wheat and barley crops, to made improvement work on the machine, consequently by preparing the appropriate thresher, solving threshing problems of wheat and barley producer farmers of our mandate area.

## Materials and Methods

### Experimental materials

The basic experimental materials were used:-Jima drum replaceable multi-crop thresher (figure.1), 12 hp *Akmi* engine, un-threshed wheat and barley crops, tachometer, DRAMINSKI moister meter, digital balance weight, a stopwatch and caliper.

### Experimental Site

The performance evaluation test was done in east Hararghe zone, at *Garamuleta* (Grawa) district at the place known as *Rasa jeneta*, which is found near to in the iterance direction of Grawa town. The site is the major wheat and barley growing area in the zone. The experiment was done by using the farmer’s harvest.



Figure1. Drum replaceable Jima multi- crop thresher

### Experimental Design

#### *Grain throughput capacity, $T_c$ (kg/hr)*

This is the capacity of the thresher in terms of the total quantity of threshed materials in sample per unit time.

$$T_c = \frac{Q_s}{T} \dots \dots \dots (1)$$

Where:  $Q_s$  = Quantity of threshed grain will be collected after a threshing operation (kg)

$T$  = Time for a complete threshing operation (hr)

### Threshing efficiency, $T_e$ (%)

This parameter will be used to determine the threshing ability of the threshers.

$$T_e = 100 - \frac{Q_u}{Q_t} * 100\% \dots \dots \dots (2)$$

Where:  $Q_u$  = quantity of un-threshed grains in sample (kg)

$Q_t$  = Total quantity of grain in sample (kg)

### Mechanical grain damage $M_d$ (%)

This parameter will be used to determine the quantity of grains damaged during threshing.

$$M_d = \frac{Q_b}{Q_t} * 100\% \dots \dots \dots (4)$$

Where:  $Q_b$  = quantity of broken grains in sample (kg)

### Moisture Content of the grain $M_c$ %

The moisture content of the grain will be determine using oven drying in which the sample will dried at 130°C for 18 hours and moisture content on wet basis will being obtained from the equation below [3]. In our case the moisture content of samples were determined using DRAMINSKI moister meter

$$M_c = \frac{W_i - W_d}{W_i} * 100\% \dots \dots \dots (5)$$

$M_c$  = moisture contain (%)

$W_i$  = initial weight of sample (kg)

$W_d$  = dried weight of sample (kg)

### Experimental Method

The thresher was driven with 12 hp *Akmi* engine. Two crops; wheat and barley, three levels of cylinder speed 1300, 1400, and 1500 and three levels of wheat and barley feed rates; 5 kg/min, 10 kg/min and 15 kg/min and at constant inlet 20mm, central-beneath 50mm and out-let 20mm drum-concave clearance.

Moisture content of the wheat grain was 12.3% and its grain straw ratio 62.1%, for barley crop 12.2 % and grain straw ratio 53.4%.

The selected experimental design for this study was RCBD design with three replications. During the test operations, the selected weight of wheat and barley were fed through the inlet part of the machine by an operator and the threshed outputs were collected from the outlets. Three samples were taken from each test of main and straw out let. From each sample pure, with husk, un-threshed and broken grain were separated, weighed and then, the result was recorded.

The above procedure was repeated thrice for all combinations of wheat and barley with cylinder-concave clearance, rpm and feed rate. The selected design was used to analyze the obtained data during the experiment. Accordingly, the two types of crops wheat and barley were taken as the main plot treatment factors, three speeds as sub-plot treatment factors, three feed rates as sub-plot-plot and treatment factors with three replications as block. To analyze the treatment factors by split plot design laid down (2x3x3) x3 factorial combinations with three replications, which result 54 numbers of trials.

### **Results and Discussions**

Using GenStat released 16.1 (sixteenth edition) the processed data for wheat crop was analyzed and the following results obtained. Coefficient of variation (CV) was 0.3% for pure grain and 61.6 % for broken grain. At alpha level of 0.05 least significant deferent values for pure and broken grain were 0.477and 0.515 % respectively. During the test it was observed that the threshing efficiency of the machine was varied in a range of 99.03% to 99.82%. Maximum threshing efficiency of 99.82% was obtained at speed of drum 1400 rpm, feed rate of 10 kg/.min and at constant inlet 20mm, and central-beneath 50mm and out-let 20mm drum-concave clearance. The 99.03 % or minimum threshing efficiency of the machine was observed at feed rate of 10 kg/ min, 1500 rpm and at constant inlet 20mm, central-beneath 50mm and out-let 20 mm drum-concave clearance. From those results we can say that threshing efficiency increases with increasing drum speed in a given range then decrease (see table 1).



The highest broken grain of 0.96% was noticed at feed rate of 10 kg/min, 1500 rpm speed of the drum and at constant drum-concave clearance of 20, 50 and 20 mm for inlet, central-beneath and outlet clearance respectively. However, the lowest broken grain percentage was 0.181 % obtained at the feed rate of 10 kg/min, 1400 rpm speed of the drum and drum-concave clearance of 20, 50 and 20 mm for inlet, central-beneath and outlet clearance respectively. From the result obtained we can say that increasing cylinder speed raises grain breakage.

Table.1. Effect of drum speed and feed rate on threshing efficiency and grain damage for wheat crop.

	Parameter	Threshing Efficiency (Mean)	Broken Grain (Mean)
Crop types	wheat		
Drum speed (rpm)	Feed rate		
	5kg/min 10 kg/min 15kg/min		
1300	S1xF1	99.54 <sup>a</sup>	0.463 <sup>a</sup>
	S1xF2	99.76 <sup>a</sup>	0.240 <sup>a</sup>
	S1XF3	99.13 <sup>a</sup>	0.867 <sup>a</sup>
1400	S2XF1	99.77 <sup>a</sup>	0.2366 <sup>a</sup>
	S2XF2	99.82 <sup>a</sup>	0.1810 <sup>a</sup>
	S2x F3	99.81 <sup>a</sup>	0.1933 <sup>a</sup>
1500	S3XF1	99.13 <sup>a</sup>	0.8700 <sup>a</sup>
	S3XF2	99.03 <sup>a</sup>	0.9600 <sup>a</sup>
	S3XF3	99.34 <sup>a</sup>	0.6566 <sup>a</sup>
Mean		99.48	0.52
LSD (0.05)		0.477	0.515

For barley crop maximum threshing efficiency 100 % was recorded at feed rate of 5 kg/min and 1300 rpm speed of drum and at constant drum-concave clearance of 20, 50 and 20 mm for inlet, central-beneath and outlet clearance respectively while, the minimum threshing efficiency 97.10 % was seen at a feed rate of 5 kg/min , 1500 rpm speed of drum and at constant drum-concave clearance of 20, 50 and 20 mm for inlet, central-beneath and outlet clearance respectively (see table 2 ) . Un-threshed grain had been one of the independent variable which was considered in the experiment but at the time of data collection on both wheat and barley crop visible un-threshed grain had not seen.

The output capacity of the machine was varied between 2.2-2.86 qt/h for wheat and barley crops. Due to its grain straw ratio value barley was showed the utmost output capacity of the

machine than wheat. The evaluated Jima wheat and barley thresher does not incorporate the cleaning system as a result, both the grain, small-size straws and dust particles were unceperately come-out in grain outlet of the machine.

Table.2. Effect of drum speed and feed rate on threshing efficiency and grain damage for barley crop

Parameter		Threshing Efficiency (Mean)	Broken grain
Crop types	Barely		
Drum speed (rpm)	Feed rate		
	5kg/min 10 kg/min 15kg/min		
1300	S1xF1	100 <sup>a</sup>	0 <sup>a</sup>
	S1xF2	99.96 <sup>a</sup>	0.0333 <sup>a</sup>
	S1XF3	99.93 <sup>a</sup>	0.0746 <sup>a</sup>
1400	S2XF1	99.92 <sup>a</sup>	0.0776 <sup>a</sup>
	S2XF2	99.916 <sup>a</sup>	0.0833 <sup>a</sup>
	S2x F3	99.86 <sup>a</sup>	0.1363 <sup>a</sup>
1500	S3XF1	97.10 <sup>c</sup>	2.8995 <sup>c</sup>
	S3XF2	97.31 <sup>c</sup>	2.6900 <sup>c</sup>
	S3XF3	98.23 <sup>b</sup>	1.7678 <sup>b</sup>
Mean		99.14	0.8625
LSD (0.05)		0.646	0.646

The output capacity of the machine was evaluated for both wheat and barley crops with long duration test by means of three samples intended for wheat and barley crops harvest 7.5 qt, 11.5qt, 20.5 qt and 1qt, 2.5qt, 5.5q respectively.

It was done at recommended feed rate 10 kg/min and drum speed 1400 rpm for wheat crop. Also for barley crop feed rate 5 kg/min and drum speed were 1300 rpm along with considering recommended moister content of the grain. Long duration test result was indicated that the machine output capacity was between 2.25-2.5qt/hr for wheat and 2.2-2.86 qt/h for barley crop. The average specific fuel consumption was observed 0.138 lit/qt and 0.113 lit/qt for wheat and barley respectively (see figure 2. and 3.) below.

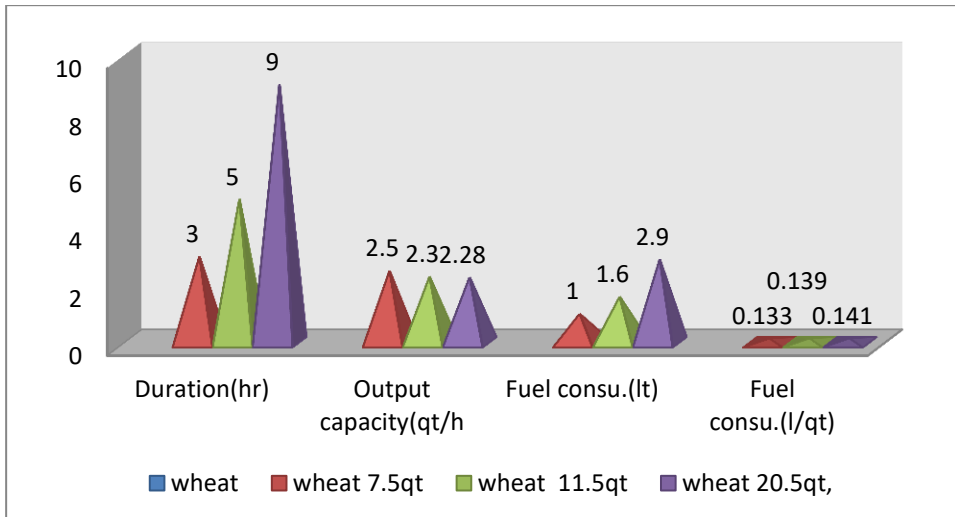

Figure2. Long duration test of drum replaceable Jima multi- crop thresher on wheat crop

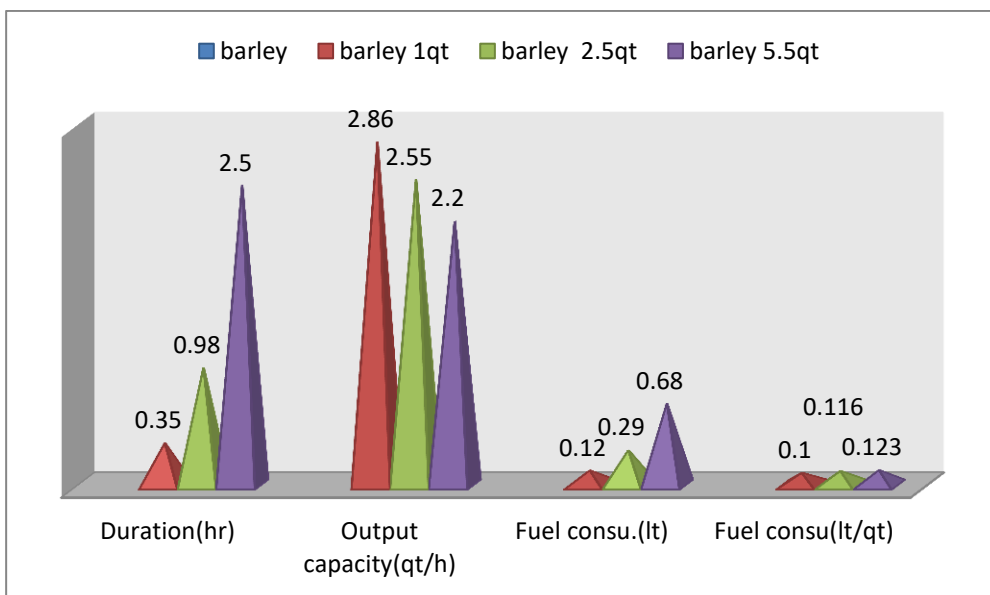

Figure3. Long duration test of drum replaceable Jima multi- crop thresher on barley crop

## Conclusions and Recommendation

### Conclusion

The evaluated wheat and barley thresher was found to be best in threshing efficiency for both crops, 99.03% - 99.82%, for wheat and 97.1 - 100% meant for barley. It is above the recommended value. The optimum conditions for thresher evaluation were set for threshing efficiency being 95% (Singhal and Thierstein, 1987). The obtained threshing capacity was

between 2.25-2.5qt/hr for wheat and 2.2-2.86 qt/h for barley. The machine doesn't have cleaning system the evaluation regarding cleaning system wasn't done so, the machine needs improvement work by incorporate cleaning system for attaining full system of the machine. Broken grain for wheat crop was between 0.19 – 0.87 % which is below the standard of 2% maximum (Sharma *et al.*, 1984). However, for barley crop it is in the range of 0 - 2.9 which is above the permissible percentage.

To get maximum efficiency, output capacity and minimum breakage (for wheat =0.46% and for barley=0%) users should adjust the drum speed on 1400 rpm, and feed rate at 10 kg/min for wheat and for barley adjust drum speed on 1300 rpm and feed rate at 5 kg/min, and considering recommended moisture content of the grain is important.

At the time of feeding the machine, the drum was pushed back grains, straw and dust particles which were blown on operator face and into the ground so that, an improvement work should be done on feeding table. An improvement work also should be done on engine set for weight reduction.

### **Recommendation**

Finally, the obtained machine performance was found to be in the acceptable ranges and taken as good results, therefore it is suggested that, the machine should be multiplied and promoted for farmers, to reduce the drudgery of wheat and barley threshing and grain losses.

### **References**

1. ASAE. (1972). American Society of Agricultural Engineers; ASAE Standard S.352-1 and 401-1. Yearbook, 2950 n Taylor, Niles Road, St Joseph, Michigan 49085.Pp 25
2. Bill A., et al., eds., " CIGR Handbook of Agricultural Engineering: Plant Production Engineering and The International Commission of Agricultural Engineering, Bernard Cheze Ministry of Agriculture, Fisheries and Food, France Volume III
3. Dr Jagdish W., "Elements of agricultural engineering" first edition 1971, published by a.k. Jain (prop) and reprints 2010 ISSN: 81-8014-044-x
4. Sharma, V.K., et al, 1984. Design, Development and Evaluation of a Tractor-Operated Multi-crop Thresher: *AMA*, vol. 15(42), pp.26-30.
5. Singhal, O.P. and Thierstein, G.E. 1987. Development of an Axial-Flow Thresher with Multi-Crop Potential: *AMA*, vol. 18(3), pp.57-65.

## Evaluation and Selection of Existing Machines for Sorghum Threshing

Tamiru Dibaba\*, Anane Gemedas\*, Tibabu Ababu

*Oromia Agricultural Research Institute, Jimma Agricultural Engineering Research Center,  
Oromia, Ethiopia*

*\*correspondent authors e-mail: [tamedibaba@gmail.com](mailto:tamedibaba@gmail.com) and [ananagemeda7@gmail.com](mailto:ananagemeda7@gmail.com)*

### Abstract

*Sorghum threshing in Ethiopia is characterized by high grain breakages and grain loss. Existing threshing methods are time - consuming and yield a low throughput. To reduce the losses, optimal levels of machine and operational parameters influencing threshing need to be established. The performance of the existing three crop threshers machine namely Fadis Sorghum thresher, Jimma Replaceable Drum Multi-Crop thresher, and Jimma multi Rice thresher was evaluated in terms of threshing capacity, threshing efficiency, cleaning efficiency, and breakage for sorghum crop. The maximum threshing capacity was observed from Jimma rice thresher which is 679.12 Kg/hr obtained at 8 kg/min feed rate and 800 rpm, maximum cleaning efficiency was observed from Jimma rice thresher which is 96.80% at occurred at 6 kg/min feed rate and 700 rpm, maximum threshing efficiency was observed from Jimma rice thresher which is 100.00% obtained at 4 kg/min feed rate and 800 rpm, and also from Jimma replaceable drum multi-crop thresher threshing efficiency was observed 100.00% obtained at 4 kg/min and 700rpm and broken grain was 4,81% from Jimma rice thresher at 800 rpm and 4 kg/min feed rate. Based on these results, the Jimma rice thresher was recommended as better machine than others interms of the evaluated parameters.*

**Key words:** *Sorghum, thereher, machine, selection, evaluation*

### Introduction

Sorghum (*Sorghum bicolor* L. Moench) is a cereal crop utilized as human food with the potential of providing food security in arid and semi-arid lands where many cereal crops produce little yield (Mamoudou HD, etal, 2006). Sorghum grows in areas of altitude 500 meters - 1700 meters above sea level (m a.s.l.), with an annual rainfall of 300mm. Sorghum can replace maize (*Zea mays* L.) as a staple food in case of crop failure as it is closely related to maize in utilization hence an alternative crop in marginal areas (Swigonova Z, etal, 2004). Sorghum is used as human food as well as animal feed and industrial raw material (Mamoudou HD, et al, 2006).

In southwestern Oromia, there is a high production area that did not give attention to minimize postharvest losses. In the 2008/2009 production season the total harvested sorghum was about 1243974.5Qt, 851781.48Qt, and 522038Qt in Jimma, Buno Bedele, and Iluababor zones respectively as the zones agricultural office said. After the crop is harvested, it undergoes several operations that, if improperly done, may result in serious losses. The average post-harvest losses of food crops such as teff, sorghum, wheat, and maize are 12.9 percent, 14.8 percent, 13.6 percent, and 10.9 percent respectively (Derege A. et al., 1989).

The threshing methods can be divided into artificial threshing, animal threshing, and mechanical threshing. Along with the rise of mechanization, more and more farmers use mechanical threshing machines in the world. In rural Africa, threshing involves beating the dried sorghum panicles with sticks on the ground or in sacks, or using a mortar and pestle. Grain is separated from dirt and chaff by winnowing.

The time required for threshing depends on variety, the degree of dryness of the grain, and the method of threshing. Thresh early to reduce field exposure to birds, rats, etc. (ensure that the moisture content is low enough); The majority of farmers thresh their seed from panicles by beating with sticks or rubbing the panicle on a hard surface like a rough stone or storing it on panicles. This contributed to high mechanical damage due to the breaking of seeds into small pieces hence reducing the seed quality (Derege A. et al., 1989). When seeds within a seed lot are broken into pieces, the embryos are damaged hence reducing the germination capacity of the seeds.

There were some threshing machines designed at different research centers such as Fadis, Melkasa, and Jimma research centers. The Fadis made sorghum threshing machine was tested at the constant grain moisture content of 20-21%, and the test result indicated that the threshing efficiency, output capacity, and cleaning efficiency were found to be 88.97-97.08%, 7-12 qt/h and 55%-78% respectively where the Jimma drum replaceable multi crop threshing machine was tested at moisture content 9.8% and the result indicated that the threshing efficiency, output capacity, and cleaning efficiency were 98.63%, 780.68 kg/hr and 98.56% respectively. Therefore, to increase production and to minimize the losses, the use of appropriate technology should be important because the threshed either by hand or by animal feet yet.

Hence, the objective of this activity was to evaluate and select the best performed sorghum threshing machine

## Materials and Methods

### Experimental site

The experiment was conducted at Jimma zone of Madara kebele of Gomma woreda

### Materials

The materials required for this study was:

- ✓ Fadis type sorghum thresher,
- ✓ Jimma drum-beater replaceable multi crop thresher
- ✓ Jimma made rice thresher
- ✓ stopwatch -for recording time of operating
- ✓ small size digital balance-for measuring output and broken grain
- ✓ digital tachometer –for measuring the speed of the machine
- ✓ oven-dry machine for measuring moisture content



Fig.1.a. Jimma Replaceable Drum Multi Crop Thresher b. Jimma Rice Thresher c. Fadis Sorghum thresher

### Methods

The experiment was conducted in factorial with RCBD design with three feed rate, three drum speed and three replications for the three threshers.

**Collected data:** The data was collected during performance testing before testing, during testing, and after testing. The data collecting from field testing and laboratory testing based on the measurement or test required. The data collected from laboratory and field test were:

### **Crop parameters**

- Moisture content
- Grain –straw ratio

### **Machine performance**

- Threshing capacity
- threshing efficiency
- cleaning efficiency
- mechanical grain damage

### **Moisture Content**

The moisture content of sorghum grain was determined using a drying oven. The grain samples were dried at 130°C for 18 hours (ASAE Standards. 2003.). the weight loss of the samples was recorded and the moisture content was determined in percentage.

The moisture content on wet basis, %:-

$$mc = \frac{\text{weight of wet sample} - \text{weight of dry sample}}{\text{weight of dry sample}}$$

### **Grain –straw ratio**

From the sorghum which was threshed, 3 samples are randomly taken of approximately 0.5kg each. The samples was placed in sealed plastic containers and taken to the laboratory where the grains and straw were separated by hand. The straw and grains from each sample were kept paired. After weighing, the samples were oven-dried at 130°C for at least 15 hours and then reweighed (Manfred, H. 1993).

The moisture content (M) on dry basis, %:

$$mc = \frac{\text{weight of wet sample} - \text{weight of dry sample}}{\text{weight of dry sample}}$$

The Grain-Straw ratio (K) was calculated as follows:-

$$k = \frac{\text{weight of dry grain}}{\text{weight of dry straw}}$$



## Determination of machine Performance Parameters

The performance tests of the sorghum threshing machines were conducted at different three threshers, at different levels of cylinder speed and three levels of feeding rates by using factorial with RCBD design of a 3x3x3 factorial experiment with three replications in each treatment and comparison between treatment means by least significance difference (LSD) at 5% level for locally available varieties separately. From the analysis of samples and sampling time, feed rate, threshing recovery, threshing efficiency, cleaning efficiency of main grain, outlet rate of damaged grains, loss of grain was calculated as follows.

### Threshing capacity

The threshing capacity was used to evaluate for how fast the thresher machine can perform its given task of threshing. It is the amount of the actual cleaned grain that a machine is able to thresh per time and it was determined using the relationship as determined by Ndirika (1994) and Mohammed (2009).

$$TC = \frac{Q_s}{T}$$

Where: TC = threshing capacity expressed in kilogram per minute (kg /h)

$Q_s$  = quantity of grains collect at the grain outlet in kilogram and

$T$  = time taken to thresh in minutes

### Threshing efficiency

Threshing efficiency was used to determine how effectively the thresher was in carrying out its primary function of threshing the crop. It is defined as the percentage ratio of the threshed grain to the total quantity of sample grain after the threshing process. The threshing efficiency was determined using the relationship as determined by Ndirika (1994) and Gbabo *et al.*, (2013)

$$TE = 100 - \frac{Q_u}{Q_T} \times 100$$

Where: TE = threshing efficiency in percentage

$Q_u$  = unthreshed quantity of grains in a sample in kg

$Q_T$  = the total quantity of grains (kg) threshed and unthreshed in the Sample

### Cleaning efficiency

The cleaning efficiency was used for the evaluation of the ability of the thresher to clean the crop effectively. The cleaning efficiency is the ratio by weight of the grains collect at the grain

outlet to the total weight of the chaff and grains collect at the same outlet expressed as a percentage. The cleaning efficiency was determined using the relationship as determined by Ndirika (1994) and Gbabo *et al.*, (2013).

$$C_E = \frac{(W_t - W_c)}{W_t} \times 100$$

Where:  $CE$  = Cleaning efficiency in percent

$W_t$  = total weight at the outlet in kilogram and  
 $WC$  = chaff weight at the outlet in a kilogram.

### **Mechanical grain damage**

Mechanical damage was used to determine the quantity of visible physical damage to grains that can be owed to the thresher. The mechanical grain damage was the expression as outlined by Ndirika (1994) and also Mohammed (2009)

$$MD = \frac{Q_b}{Q_t} \times 100$$

Where:  $MD$  = Mechanical grain damage (in percent),  
 $Q_b$  = the number of damage grains in kilogram, and  
 $Q_t$  = total weight of grains in the sample (kg).

### **Data analysis**

The collecting data was analyzed using a factor design with the RCBD method. The treatments under study were tested at three selecting feeding rates (4kg/min, 6kg/min, 8kg/min), three cylinder speeds (600rpm, 700rpm, 800rpm), and three threshers were applied at three replications and analysis by statistix 8software.

## **Results and Discussion**

The performance of the three machines (Fadis sorghum thresher (FST), Jimmareplaceable Drum multithresher (JRDMCT), and Jimma rice thresher (JRT)) was evaluated at various drum speed and feed rate at average moisture content of 18.3% and grain-straw ratio of 1:63 sorghum grain in terms of threshing capacity, threshing efficiency, cleaning efficiency, percentage of grain damaged.

## Threshing capacity

Table 1: Threshing capacity of the three threshers at different speed and feed rate

Feed rate x speed				Speed (rpm)	Mean	Feed kg/hr	Mean	Type	Mean
		<u>Speed(rpm)</u>							
Feed rate (kg/min)	600	700	800	600	Mean	4	Mean	Type	Mean
				<b>600</b>	499.53 <sup>a</sup>	<b>4</b>	508.02 <sup>b</sup>	<b>FST</b>	394.12 <sup>c</sup>
<b>4</b>	420.99 <sup>d</sup>	492.79 <sup>cd</sup>	610.27 <sup>a</sup>	<b>700</b>	555.76 <sup>b</sup>	<b>6</b>	545.82 <sup>b</sup>	<b>JRDMCT</b>	590.26 <sup>b</sup>
<b>6</b>	495.23 <sup>bcd</sup>	567.67 <sup>ab</sup>	574.60 <sup>abc</sup>	<b>800</b>	608.22 <sup>a</sup>	<b>8</b>	609.66 <sup>a</sup>	<b>JRC</b>	<b>679.12<sup>a</sup></b>
<b>8</b>	582.37 <sup>ab</sup>	606.84 <sup>a</sup>	639.78 <sup>a</sup>						
<b>SE</b>			44.11		25.46		25.46		25.46
<b>LSD</b>			0.1966		0.0003		0.0007		
<b>CV</b>									16.88

The maximum threshing capacity was 679.12 kg/hr, which is observed from Jimma rice thresher (JRC). The mean capacity of the three threshers is significantly different, but this threshing capacity was not significantly different among feed rate and speed means.

## Threshing Efficiency

Table 2: Threshing Efficiency of the three threshers at different speed and feed rate

Feed rate x speed				Speed (rpm)	Mean	Feed kg/hr	Mean	Type	Mean
		<u>Speed(rpm)</u>							
Feed rate (kg/min)	600	700	800	600	Mean	4	Mean	Type	Mean
				<b>600</b>	99.63 <sup>b</sup>	<b>4</b>	99.55 <sup>b</sup>	<b>FST</b>	99.5 <sup>a</sup>
<b>4</b>	99.46 <sup>bc</sup>	99.42 <sup>c</sup>	99.77 <sup>a</sup>	<b>700</b>	99.63 <sup>b</sup>	<b>6</b>	99.71 <sup>a</sup>	<b>JRDMCT</b>	<b>100<sup>a</sup></b>
<b>6</b>	99.68 <sup>ab</sup>	99.64 <sup>abc</sup>	99.80 <sup>a</sup>	<b>800</b>	99.81 <sup>a</sup>	<b>8</b>	99.77 <sup>a</sup>	<b>JRC</b>	<b>100<sup>a</sup></b>
<b>8</b>	99.75 <sup>a</sup>	99.72 <sup>a</sup>	99.85 <sup>a</sup>						
<b>SE</b>			0.1294		0.0747		0.0747		0.0747
<b>LSD</b>			0.6806		0.0128		0.0124		
<b>CV</b>									0.28

The maximum threshing efficiency of the machine was about **100.00%** which is observed from Jimma rice thresher (JRC) and Jimma replaceable Drum multi thresher (JRDMCT). This threshing efficiency was not significantly different among feed rate, speed means, and types of the thresher.

## Cleaning Efficiency

Table3: Cleaning Efficiency of the three threshers at different speed and feed rate

Feed rate x speed				Speed (rpm)	Mean	Feed kg/hr	Mean	Type	Mean
Feed rate (kg/min)		Speed(rpm)							
	<b>600</b>	<b>700</b>	<b>800</b>	<b>600</b>	93.96 <sup>a</sup>	<b>4</b>	93.46 <sup>a</sup>	<b>FST</b>	91.91 <sup>b</sup>
<b>4</b>	95.28 <sup>a</sup>	93.50 <sup>ab</sup>	91.61 <sup>b</sup>	<b>700</b>	92.65 <sup>a</sup>	<b>6</b>	93.72 <sup>a</sup>	<b>JRDMCT</b>	90.20 <sup>b</sup>
<b>6</b>	95.28 <sup>a</sup>	92.28 <sup>ab</sup>	93.61 <sup>ab</sup>	<b>800</b>	92.30 <sup>a</sup>	<b>8</b>	91.72 <sup>b</sup>	<b>JRC</b>	<b>96.80<sup>a</sup></b>
<b>8</b>	91.32 <sup>b</sup>	92.16 <sup>b</sup>	91.69 <sup>b</sup>						
<b>SE</b>			1.5038		0.8682		0.8682		0.8682
<b>LSD</b>			0.1979		0.1405		0.0503		
<b>CV</b>									3.43

The maximum cleaning efficiency of the machine was about **96.80%** which is observed from Jimma rice thresher (JRC). This cleaning efficiency was not significantly different among feed rate, speed, and types of thresher mean.

## Mechanical grain damaged

Table4: Percent of mechanical grain damaged of the three threshers at different speed & feed rate

Feed rate x speed				Speed (rpm)	Mean	Feed kg/hr	Mean	Type	Mean
Feed rate (kg/min)		Speed(rpm)							
	<b>600</b>	<b>700</b>	<b>800</b>	<b>600</b>	00.00 <sup>b</sup>	<b>4</b>	1.58 <sup>a</sup>	<b>FST</b>	00.00 <sup>b</sup>
<b>4</b>	00.00 <sup>b</sup>	2.01 <sup>ab</sup>	2.74 <sup>a</sup>	<b>700</b>	2.03 <sup>a</sup>	<b>6</b>	2.11 <sup>a</sup>	<b>JRDMCT</b>	00.00 <sup>b</sup>
<b>6</b>	00.00 <sup>b</sup>	3.15 <sup>a</sup>	3.19 <sup>a</sup>	<b>800</b>	2.51 <sup>a</sup>	<b>8</b>	1.11 <sup>a</sup>	<b>JRC</b>	<b>4.81<sup>a</sup></b>
<b>8</b>	00.00 <sup>b</sup>	1.74 <sup>ab</sup>	1.60 <sup>a</sup>						
<b>SE</b>			0.5621		0.5621		0.5621		0.5621
<b>LSD</b>			0.7283		0.0000		0.2100		
<b>CV</b>									128.56

The maximum percent of mechanical grain damaged of the machine was about **4.81%** which is observed from Jimma rice thresher (JRC). This percent of mechanical grain damaged was not significantly different among feed rate, speed, and types of thresher mean.

## Conclusion and Recommendation

### Conclusion

- According to the result, Fadis sorghum thresher (FST) had threshing capacity; threshing efficiency; cleaning efficiency, and percent of damaged grain were 394.12kg/hr at 8kg/min feed rate and 800 rpm, 99.5% at 8 kg/min feed rate and 800rpm, 91.91 at 6kg/min feed rate and 800rpm, and 0.00% respectively.
- Jimma rice thresher (JRC) had threshing capacity; threshing efficiency; cleaning efficiency and percent of damaged grain were 679.12kg/hr at 8kg/min feed rate and 800rpm. 100% at 4kg/min feed rate and 800rpm, 96.80% at 6kg/min feed rate and 700rpm and 4.81% at 4kg/min feed rate and 800 rpm respectively.
- Jimma replaceable Drum multi thresher (JRDMCT) had threshing capacity; threshing efficiency; cleaning efficiency and percent of damaged grain were 590.26kg/hr at 6kg/min feed rate and 800rpm, 100% at 4kg/min feed rate and 700rpm, 90.20% at 6kg/min feed rate and 700 rpm and 0.00% respectively.

### Recommendation

The selection of these machines was made on threshing capacity, threshing efficiency, and cleaning efficiency. Therefore it was better to use the rice thresher than the other.

### Reference

- ASAE Standards. 2003. S352.2FEB03. Moisture measurement unground grain and seeds. St Joseph, Michigan. ASAE
- Derege A. et al., 1989. Postharvest losses assessment in selected cereal crops
- Gbabo A., Ibrahim M. G. and Matthew S. A. (2013). Design, fabrication and testing of a millet thresher. *Journal of AgricSci* 1 (14): 100-106
- Mamoudou HD, Hurry G, Alfred S, Alphons GJ, Van B. 2006. Sorghum grain as human food in Africa: relevance of content of starch and amylase activities. *African Journal Biotechnology* 5, 384 - 395.
- Manfred, H. 1993. Harvest index versus grain/straw-ratio. Theoretical comments and experimental results on the comparison of variation. *Euphytica*, 68:27-32.
- Ndirika, V.I.O., 1993. Development and performance evaluation of a millet thresher. *Journal of Agricultural Technology*, 1(1): 2-10
- Swigonova Z, Lai J, Ramakrishna W, Llaca V. 2004. Close split of sorghum and maize genome progenitors. *Genome Research* 14, 1916–1923.

# Irrigation, Drainage and Water Harvesting Technologies

## Evaluation of Alternative, Fixed, Conventional Furrow Irrigation Systems and Irrigation Water Levels on Potato Yield at Oda Sirba Scheme

Asnake Tilaye\*, Bayan Ahmed and Fikadu Gemedu

Oromia Agricultural Research Institute, Asella Agricultural Engineering Research Center, P.O.Box: 06, Asella, Ethiopia. \* Corresponding author: [asnake127@gmail.com](mailto:asnake127@gmail.com)

### Abstract

Water availability is becoming a critical issue in Ethiopia so that preferable irrigation technologies need to be developed and water productivity of irrigated crops through water management is a vital option in water scarce areas. Hence, the objective of this study was to enhance potato tuber production through the application of different irrigation system and deficit irrigation application under highland climatic condition. Field experiment was carried out at farmer field of Oda Sirba scheme for three consecutive years with three furrow irrigation system and one deficit irrigation 80%ETc and control irrigation 100%ETc replicated three times in a split plot design. Obtained results revealed that, the highest seasonal water requirement value of 497.8mm was at CFI with full irrigation application while, the lowest value of 199.2 mm was by AFI and FFI with 80%ETc. The analysis of variance indicated that there was significant ( $P \leq 0.05$ ) difference obtained for yield and WUE of potato tuber. The highest yield of 36.12 t ha<sup>-1</sup> was obtained from control treatment with CFI while FFI at deficit application had the lowest yield of 26.3 t ha<sup>-1</sup>. The nearest yield of 34.22 t ha<sup>-1</sup> was obtained by AFI method with full irrigation application. Higher water use efficiency was observed at AFI method at a control level with 13.75 kg m<sup>-3</sup> and higher than at 80%ETc with 13.46 kg m<sup>-3</sup> but there is no significant variation between them. Highest benefit cost ratio of 47.85 was obtained from AFI method at control level. Yield and water use efficiency based comparison had shown that there was significant difference between the yield and WUE obtained at AFI and CFI, while applied water in AFI was reduced by 50%. Therefore, it can be concluded that increased water saving and associated water productivity through the use of AFI with 100% ETc, can solve problem of water shortage which improve WUE without significant reduction of yield. AFI system at full irrigation application appears to be a promising alternative for water conservation and labor saving with negligible reduction in yield.

**Key words:** Irrigation level, Alternate furrow, deficit irrigation, Potato, Water use efficiency

## Introduction

Land and water scarcity are major constraints for the production of food required to satisfy the quantitative and qualitative shifts of the world's demand in the mid-twenty-first century. Moreover, the effect of a global climatic change is worsening the scarcity of water for irrigation (Behera and Panda, 2009).

There is a growing concern in water use because of the conflict between the environment and agriculture particularly in lowland areas, where total base flows are diverted for irrigation without releasing adequate amount of water for downstream domestic, industrial and ecological conservation. According to study conducted by OESO (1999), there is 1.7 million hectares of land suitable for surface irrigation in Oromia out of which 93,185 hectares (5.5%) have been developed so far. The amount of water utilized for the purpose of irrigation is estimated to be about 1.5% of the total 58 billion m<sup>3</sup>, the mean annual runoff, generated in the region and the groundwater potential of (2.1 billion m<sup>3</sup>). On the contrary, it has been projected that about 1.132 million households were food insecure in the year 2003/2004 in Oromia.

For a country like Ethiopia, there is no readily identifiable yield increasing technology other than improved seed-water-fertilizer approach. Irrigation will, therefore, play an increasingly important role now and in the future both to increase the yield from already cultivated land and to permit the cultivation of what is today called marginal or unusable land due to moisture deficiency. Improvement of irrigation water management is portrayed as the key issue in coping up with crop irrigation needs and future water scarcity. One of the irrigation management practices which could result in water saving is through deficit irrigation (Eck et al., 1987). One more option to increase water productivity through deficit level is alternate and fixed furrow irrigation system.

Furrow irrigation water application system is most popular of surface irrigation, as it requires a smaller initial investment compared to other types of irrigation-water application systems. This type of irrigation method is the most widely used in our country in almost all-large and small irrigation schemes. It has been reported by FAO (2001) that 97.8% of irrigation in Ethiopia is done by surface methods of irrigation especially by furrow system in farmer's fields and majority of the commercial farms. Irrigation by the furrow method is accomplished by running water in small channels (furrows) that carry the water. Water seeps into the bottom and sides of the furrows as it moves down or across the slope of the field to provide the desired wetting of soil. Furrows are particularly suitable for irrigating crops, which are subject to injury if water covers the crown or stems of the plants. The studies of Du et.al, (2010)

improved by converting conventional furrow irrigation to alternate furrow irrigation (AFI) in order to increase water use efficiencies.

Conventional furrow irrigation (CFI), where every furrow is irrigated during consecutive watering, is known to be less efficient particularly where there is shortage of irrigation water. CFI usually causes excessive deep percolation at the upper part of the furrow, insufficient irrigation at the lower part and considerable runoff, resulting in low application efficiencies and distribution uniformities. Proper furrow irrigation practices can minimize water application and irrigation costs, save water, control soil salinity buildup and result in higher crop yields (Booher, 1974). One recent development towards optimum utilization of irrigation is to irrigate alternate furrows during each irrigation time (Zhang et al., 2000; Kang et al., 2000). By irrigating alternative furrows, half of root is exposed to wet soil condition and the other half is exposed to dry soil condition.

Many ways to save agricultural water use have been investigated. Various researchers (Hodges *et al.*, 1989; Graterol *et al.*, 1993; Stone and Nofziger, 1993) have used wide spaced furrow irrigation or skipped crop rows as a means of improving WUE. They selected some furrows for irrigation while other adjacent furrows were not irrigated for the whole season i.e. fixed furrow irrigation (FFI) which means that irrigation is fixed to one of the two neighboring furrows. In general, these techniques are a trade-off a lower yield for a higher WUE. This technique therefore is expected to save irrigation water with a potential to irrigate more land; it also helps to minimize the labor requirement in furrow irrigation technique.

Alternate furrow irrigation (AFI) is also practiced when the supply of water is limited. Besides, this alternate furrow method is adopted where salt is a problem. Water is discharged in alternate furrows keeping the in-between furrow dry. In the subsequent irrigation, water is allowed to flow through the alternate furrows that had been kept dry on the previous occasion. This method saves quite a good amount of water and is very useful and crucial in areas of water scarcity and salt problems.

Deficit irrigation is an optimization strategy in which irrigation is applied during drought-sensitive growth stages of a crop. Deficit irrigation aims at stabilizing yields and plays an important role in increasing water use efficiency (WUE) (Mati, 2012).

Under conditions of scarce water supply, application of deficit irrigation could provide greater economic returns than maximizing yields per unit of water (Enchalew *et al.*, 2016). The



deficit irrigation has been considered worldwide as a way of maximizing water use efficiency (WUE) by eliminating irrigation that has little impact on yield.

Potato (*Solanum tuberosum L.*) is the world's most important root and tuber crop worldwide. It is grown in more than 125 countries and consumed almost daily by more than a billion people. Its ability to produce high volume food per unit area and time (Israel *et al.*, 2012) and its ease of cultivation and nutritive content have made it a valuable food security and cash crop for millions of farmers (FAO, 2009).

In Ethiopia, potato is one among the most economically important crops as a source of food and cash in the country (Adane *et al.*, 2010). Annual potato production in Ethiopia has increased from 349,000 tons in 1993 to around 743, 153 tons in 2018 (FAOSTAT, 2020) and can potentially be grown on about 70% of arable land in the country (CSA, 2008/2009; Gebremedhin *et al.*, 2008). However, the average yields of potato in African are 6 to 12 tons per hectare (compared to 35–45 tons ha<sup>-1</sup> in Europe and North America) CIP (2017) and specifically, in Ethiopia, it is 7.97 tons ha<sup>-1</sup> CSA (2016) which is far below the potential of the crop (CIP, 2017). Moisture stresses is among the major constraints of potato production in Ethiopia (CIP, 2017; Keefelegn *et al.*, 2012; Tekalign & Hammes, 2005). Hence, the main objective of this research was, therefore, to enhance potato production through the application of different irrigation system and deficit irrigation application under highland climatic condition.

## **Materials and Methods**

### **Materials**

Representative composite soil samples that were collected from 0 – 15, 16 – 30, 31 – 60 cm soil depths weretaken to Oromia water works construction Enterprise laboratory for Textural, FC, PWP, ECe, pH, Organic Carbon and OM analysis.

### **Methods**

#### ***Soil Sampling and Analysis***

The bulk density of the field was determined from undisturbed soil samples from soil depth of 0 – 15, 16 – 30, 31 – 60 cm using the core sampler having a dimensions of 5.0 cm diameter and 5.0 cm height (98.21 cm<sup>3</sup>). The samples were oven driedfor 24 hours at temperature of 105°C to obtain dry soil sample. Hence, the bulk density (BD) was computed following Eq. (2.1).

$$BD\left(\frac{g}{cc}\right) = \frac{\text{weight of dry soil (g)}}{\text{volume of core sampler}(cm^3)} \quad (2.1)$$

Moisture contents at field capacity and permanent wilting point were measured using a pressure plate apparatus at Oromia water works construction Enterprise laboratory by applying pressures at 0.33 and 15 bars, respectively. The moisture content of the soil samples on volume basis were determined by multiplying the gravimetric water content on weight basis by the bulk density.

### Experimental Design Procedure

Field experiment was conducted for three consecutive years to evaluate the effect of irrigation methods and irrigation levels on yield and water productivity of potato. The experimental treatments include three irrigation systems, viz., the Alternate furrow irrigation, fixed furrow irrigation, conventional furrow irrigation and one deficit irrigation application levels, viz., 80%ETc, and a control irrigation of 100% ETc application. The experimental design was a split plot design with three replications. The irrigation system was used as main plots and irrigation water levels as sub-plots (Table 1).

Table.1. Treatment combination

Irrigation systems (main-plot)	Irrigation Level (sub-plot)	
	100% ETc	80% ETc
Alternative furrow irrigation	T <sub>1</sub>	T <sub>2</sub>
Fixed furrow irrigation	T <sub>3</sub>	T <sub>4</sub>
Conventional furrow irrigation	T <sub>5</sub>	T <sub>6</sub>

### Crop Agronomy

The experimental field was divided into 18 plots of 5 m by 5m to accommodate a plot consisted of seven ridges and eightfurrows and representing a single treatment. The plots and replications had a buffer zone of 1.5 m and 3 m length respectively from each other to eliminate influence of lateral flow of water.The crop wasplanted at a plant and row spacing of 30 cm and 83cm respectively.Field channel was constructed for each block to irrigate the field. For each plot, box shaped structures were constructed to dissipate the energy of water diverted to the plots.

Potato tuber Belete variety was planted on the experimental field by hand in row, after land is prepared well and pre irrigated. Land preparation includes plowing, leveling, layout preparation and main and field canal preparation.

Irrigation scheduling was done based on control treatment (100% ET<sub>c</sub>). The other deficit treatments received lower amount of irrigation water than the control treatment based on their level of moisture stress percentage. However, the same irrigation interval was used as that of control treatment. The control treatment was irrigated based on the allowable moisture depletion level ( $p = 0.35$ ) in the effective root depth that aims to refill the soil moisture to field capacity and applied water to the field was measured by parshall flume.

The experiment totally had eighteen experimental units. Blocking was taken as replication. All of these treatments were randomly assigned to each experimental unit to avoid any bias towards the selection.

## **Crop Water Requirements and Irrigation Water Management**

### ***Crop water requirement***

Reference evapotranspiration, ET<sub>o</sub> was estimated using FAO Penman-Monteith equation from long term meteorological data collected from Meraro meteorological station with the help of CROPWAT 8.0 model software. Seasonal crop water requirements, ET<sub>c</sub> was estimated by multiplying long term ET<sub>o</sub> value with the established K<sub>c</sub> value (Eq. 2.2).

$$ET_c = ET_o \times K_c \quad (2.2)$$

Where: ET<sub>c</sub> is Crop evapotranspiration (mm/day);

ET<sub>o</sub> is Reference crop evapotranspiration (mm/day)

K<sub>c</sub> is Crop coefficient (fraction)

Due to differences in evapotranspiration during the various growth stages, the K<sub>c</sub> for a given crop varies over the growing period. The growing period can be divided into four distinct growth stages: initial, crop development, mid-season and late season. The growth period of potato in the experimental site is 120-days and it was divided into four stages, viz, initial stage (20 days), development stage (40 days), mid stage (40 days) and late stage (20 days). The K<sub>c</sub> for potato crop under Bokoji climatic condition which is considered as semi-humid were established from the range listed as 0.4 – 0.5 for the initial, 1.05 – 1.2 for the mid stage and 0.85–0.95 for the late growth stages by (Doorenbos and Kassam, 1979) as shown in (Table 2).

Table 2. Potato growth stage and crop coefficient (Kc) under Bokoji climatic condition

Growth stage	Initial	Development	Mid	Late
Development day	20	40	40	20
Kc value	0.43	0.73	1.1	0.88
Root depth (m)	0.30 - 0.42	0.43 – 0.60	0.60	0.60

### Irrigation water management

The soil moisture level in all plots was brought to field capacity for each treatment in the last irrigation during the common irrigation time. The soil water availability in the experiment was tested from routine measurements of soil moisture content by the gravimetric method.

The wet soil samples was weighed and placed in an oven dry at a temperature of 105°C and dried for 24 hours. The gravimetric water content was converted to equivalent depth (D) from the Eq. (3).

$$D = \frac{W_w - W_d}{W_d} \times BD \times drz \quad (2.3)$$

Where: D is the depth of available soil moisture (mm);

Ww is wet soil weight (gm);

Wd is dry soil weight (gm);

BD is the soil dry bulk density (gm cm<sup>-3</sup>)

drz is the sampling depth within the crop root depth (mm).

The soil moisture depleted between irrigation was obtained from Eq. (2.4).

$$IRn = (FC - D) \quad (2.4)$$

Where: IRn is the net irrigation requirement (mm)

FC is the soil moisture content at field capacity (mm).

### Irrigation scheduling

Total available water (TAW) was computed from the moisture content of field capacity and permanent wilting point using the following Eq. (2.5).

$$TAW = (FC - PWP) \times BD \times Dz \quad (2.5)$$

Where: TAW is the total available water in the root zone (mm),

FC and PWP are moisture content at field capacity and permanent wilting point (%) on weight basis respectively

Dz is the root zone depth of potato at times of each irrigation

For maximum crop production, irrigation schedule was fixed based on p-value. The p for potato that was used in this study was 35% of TAW ( $p = 0.35$ ) (Allen *et al.*, 1998).

Hence, RAW was computed from the Eq. (2.6).

$$RAW = TAW \times p \quad (2.6)$$

Where: RAW is the readily available water or net irrigation depth, IR<sub>n</sub> (mm), p is allowable permissible soil moisture depletion fraction and TAW is total available water in the root depth (mm).

Hence, the IR<sub>n</sub> of irrigation was computed from Eq. (2.7).

$$IR_n = TAW * P \quad (2.7)$$

Where: IR<sub>n</sub> is the net irrigation requirement (mm) and p. is depletion fraction.

Irrigation interval, f, was estimated using the following Eq. (2.8).

$$f = \frac{IR_n}{ET_c} \quad (2.8)$$

Where, f is irrigation interval (day) and ET<sub>c</sub> is mean daily crop water requirement (mm day<sup>-1</sup>)

Whenever there is rainfall between irrigation, the IR<sub>n</sub> could be obtained from the Eq. (2.9).

$$IR_n = ET_c - P_{eff} \quad (2.9)$$

Where, P<sub>eff</sub> is effective rainfall (mm)

The effective rainfall, P<sub>eff</sub> was estimated using the method given by (Allen *et al.*, 1998) as,

$$P_{eff} = 0.6 \times P - \frac{10}{30/31} \quad \text{for month} \leq \frac{70}{30/31} \text{ mm} \quad (2.10)$$

$$P_{eff} = 0.8 \times P - \frac{24}{30/31} \quad \text{for month} > \frac{70}{30/31} \text{ mm} \quad (2.11)$$

Where: P is daily rainfall (mm)

### **Field application efficiency and gross irrigation water requirement**

Field irrigation application efficiency (E<sub>a</sub>) is the ratio of water directly available in crop root zone to water received at the field inlet. It is affected by the rate of supply, infiltration rate of the soil, storage capacity of the root zone and land leveling. Water is mostly lost through deep

percolation at the head end and through runoff at the tail end in furrow irrigation and deep percolation and evaporation in basin.

Furrow irrigation could reach a field application efficiency of 70% when it is properly designed, constructed and managed. The average ranges vary from 50 to 70%. However, a more common value is 60% (FAO, 2002a). Moreover, field application efficiency of heavy soil is 60% (Chandrasekaran *et al.*, 2010). For this particular experiment, irrigation efficiency was taken as 60%, which is common for surface irrigation method in furrow irrigation. Based on the net irrigation depth and irrigation application efficiency, the gross irrigation water requirement was calculated based on eq. (2.12).

$$IR_g = \frac{IR_n}{E_a} \quad (2.12)$$

Where:  $IR_g$  the gross irrigation requirement (mm)

$E_a$  is the field application efficiency (%).

### **Setting and discharge measurement of parshall flume**

Irrigation water applied to each experimental plot was measured by 3-inch Parshall flume (PF) made from metal sheet and installed 10 m away from the nearest plot along main canal. Leveling in all direction of converging section was checked. Leveling for the diverging section checked only across the waterway, as the base of the diverging part of PF is slightly slope upward. The entrance section was set 4 cm above the canal bed to avoid submergence flow and stone riprap was put in the downstream side on canal bed to minimize downstream scouring. Only one measurement was required to determine flow rate of free flow condition. This is the height of water from gauge of PF written on two-third surface wall of the entrance section.

Calculated gross irrigation was finally applied to each experimental plots based on the treatments proportion. Volume of water applied for every treatment was determined from plot area and depth of gross irrigation requirement. Time required to irrigate each treatment was calculated from the ratio of volume of applied water to the discharge-head relation of 3-inch PF. Since discharge level might vary at field condition, time required was calculated from 5 to 15 cm head levels. The time required to deliver the desired depth of water into each furrow was calculated using eq. (2.13) given by (Michael, 2008).

$$t = \frac{A \times d_{\text{gross}}}{Q} \quad (2.13)$$

Where: dg -gross depth of water applied (mm), t -application time (sec), A-plot Area (m<sup>2</sup>) and Q-flow rate (l/s)

To apply calculated water the canal was wet until the head become constant at peak head discharge to reduce variation of water divert to plots far from and near to the PF.

### Data Collection

The sample locations were selected systematically in the central ridges randomly (4 m x 4.15 m). Yield data were collected from plants in the net plot area of (16.6 m<sup>2</sup>).The collected parameters weremarketable tuber yield (tha<sup>-1</sup>), unmarketable tuber yield (t ha<sup>-1</sup>), total tuber yield (t ha<sup>-1</sup>) and water productivity (Kg m<sup>-3</sup>).

**Marketable tuber yield (t ha<sup>-1</sup>):**- was done by weighing all the tubers which were free from defects, disease, crack, and other physiological disorders and not underweight per net plot area and converting into ton per hectare (Tesfaye *et al.*, 2013).

**Total tuber yield (t ha<sup>-1</sup>):**- was calculated as the sum of the weights of marketable and unmarketable tubers from the net plot area and transformed into ton per hectare.

**Water Use Efficiency (kg m<sup>-3</sup>):** Water use efficiency sometimes called water productivity is simply the ratio of the water beneficially used and the quantity of water delivered. Water productivity was determined based on the ratio of yield of potato (bulb yield per hectare) to the net irrigation depth plus effective rainfall used from establishment to harvest expressed as (kg) of bulb yield per (m<sup>3</sup>) of water. It was calculated based on the Chandrasekaran *et al.* (2010) formula using eq. (2.14)

$$WP = \frac{Y_a}{T_{wu}} \quad (2.14)$$

Where: WP-Water productivity (kg/m<sup>3</sup>), Ya-Actual yield (kg/ha), Twu–Total water used (m<sup>3</sup>/ha)

### Economic Water Productivity

Economic water productivity analysis was begun by considering the general relationship between the crop water use and crop yield per hectare of land at different irrigation application levels using the partial budget analysis. For economic evaluation of the total return, net benefit, marginal return rate and cost benefit ratio using the different amount of water applied, the Partial Budget Analysis (PBA) was used following the CIMMYT procedure

(CIMMYT, 1988). It is a way of calculating the total costs that vary and the net benefits of each treatment (CIMMYT, 1988).

Economic data include input cost like cost for water (water pricing), potato tuber, fertilizers, land rent, chemicals and labor of production. However, the costs that varied among treatments were cost of water and labor for watering during experimental season. As an output, total gross benefit was calculated from tuber yield of potato. Local market price of potato tuber was assessed during the harvest time and was changed to hectare bases. Benefit cost ratio for each treatments were evaluated and income was calculated on the basis of local market price of potato on site during harvesting time.

According to CIMMYT (1988), the average yield was adjusted down wards by 10%. The gross returns were computed by multiplying average market rate with the yield of respective treatments during the crop harvesting period. The variable costs of this experiment among treatments were cost of irrigation water and costs of labor for irrigating. The field price of potato during the harvesting season was 12 Birr kg<sup>-1</sup>. The net income was calculated by subtracting total variable cost production from total return using eq. (2.15) (Kuboja and Temu, 2013).

$$NI = TR - TVC \quad (2.15)$$

Where: NI -Net income, TR -Total income from sales, TVC -Total variable cost spent during production.

The marginal return rate in measures the increase of the net income, which is generated by each additional unit of expenses and is computed as using eq. (2.16)

$$MRR = \frac{\Delta NI}{\Delta VC} \quad (2.16)$$

Where: MRR-Marginal rate of return (%),  $\Delta NI$  – change in net income,  $\Delta VC$  – change in variable cost

### **Statistical Analysis of Data**

The collected data were statistically analyzed using statistical analysis system (SAS) version 9.0 statistical package using procedure of general linear model (SAS, 2002) for the variance analysis. Mean comparisons were executed using least significant difference (LSD) at 5% probability level when treatments show significant difference to compare difference among treatments mean.



## Results and Discussion

### Soil Analyses

Some of the physico-chemical properties of the soil on experimental site such as texture, bulk density, field capacity, permanent wilting point, pH, EC, organic matter content, organic carbon and total nitrogen were analyzed and summarized below (Table 1 and 2).

### Physical Properties of Soil

The laboratory results of the average soil physical properties of the experimental site were presented in (Table 1) below.

Table 2. Average soil physical properties of experimental site

Depth (cm)	Bulk density (g/cc)	FC (%)		PWP (%)		TAW		Texture		
		(V/V)	(V/V)	(mm/m)	(mm)	% Sand	% Silt	% Clay	Class	
0 – 15	0.95	37.3	19.50	178.00	26.7	27.33	28.00	44.67	Clay	
16– 30	1.07	37.6	19.70	179.00	26.85	29.33	31.33	39.33	Clay	
31 – 60	1.14	39	20.20	188.00	56.4	26.00	30.00	44.00	Clay	
<b>Aver.</b>	<b>1.05</b>	<b>37.97</b>	<b>19.80</b>	<b>181.67</b>	<b>36.65</b>	<b>27.56</b>	<b>29.78</b>	<b>42.67</b>	<b>Clay</b>	

The average result of the soil physical properties from the experimental site showed that the composition of sand, silt and clay percentage were 27.56%, 29.78% and 42.67% respectively. Thus according to USDA Soil textural classification, the soil is classified as Clay.

Bulk density can be managed, using measures that limit compaction and build soil organic matter. The average bulk density of the experimental soil varied from 0.95 g/cm<sup>3</sup> at the top root zone (0 – 15 cm) to 1.14 g/cm<sup>3</sup> at the lower root zone layer (31 – 60 cm) (Table 1). Bulk density at the lower root zone layers are more compacted and have less organic matter, less aggregation, and less root penetration compared to top root layers, therefore contain less pore space (Brady and Weil, 2002). The weighted average bulk density of the experimental site was 1.05 g/cm<sup>3</sup>.

Total available water (TAW) which is the amount of water that a crop can extract from its root zone is directly related to variation in field capacity and permanent wilting point. As a result, high value of TAW (188.00 mm/m) was found in subsurface soil, whereas lower values (178.00 mm/m) were found in the top soil (Table 1). The average value of TAW was 181.67 mm/m (Brouwer *et al.*, 1985).

## Chemical properties of soil

Table 3. Average chemical properties of soil at the experimental site

Depth (cm)	pH	Total organic matter (% OM)	Total organic carbon (% OC)	ECe (ds/m)
0 – 15	5.27	3.15	1.83	0.10
16 – 30	5.13	3.19	1.85	0.12
31– 60	5.13	3.24	1.88	0.09
<b>Aver.</b>	<b>5.18</b>	<b>3.20</b>	<b>1.85</b>	<b>0.10</b>

The average pH value of the experimental site through the analyzed soil profile was found to be in recommended range with average value of 5.18 (Table 2). According to Doorenbos and Kassam (1979) potato requires a well-drained, well-aerated, porous soil with pH range of 5.0 to 6.0.

The average Organic Matter content and Organic Carbon content of the soil had an average value of 3.20 %, 1.85 % respectively over 60 cm depth of soil profile. An average electrical conductivity of an experimental soil is 0.10 ds/m. soils that had ECe < 2 (ds/m) was non saline (Cass, 1998).

## Irrigation water applied of potato tuber throughout the growth stages

Gross water applied for each stage was listed in (Table 3). Comparison of irrigation water used in alternating furrow irrigation (AFI), fixed furrow irrigation (FFI) and conventional furrow irrigation (CFI) under two different irrigation application levels and water savings from each treatment were shown in (Table 3) below.

Table 3. Water applied per growth stage and percent of water saved from each treatment

Treatment	Growth stage				IRg (mm)	Water saved (%)
	Initial	Development	Mid	Late		
AFI 100% ETc	27	40.6	124.95	56.35	248.9	50
AFI 80% ETc	21.6	32.48	99.96	45.08	199.12	60
FFI 100% ETc	27	40.6	124.95	56.35	248.9	50
FFI 80% ETc	21.6	32.48	99.96	45.08	199.12	60
CFI 100% ETc	54	81.2	249.9	112.7	497.8	0
CFI 80% ETc	43.2	64.96	199.92	90.16	398.24	20

From the concept of AFI and FFI, water applied only to two furrow (even or odd) at each successive irrigation event, so water saved from these irrigation methods was greater by saved water of neighbor furrow each event through the growth season, even though, the yield obtained was less than full irrigation application.

From (Table 3) water saved from treatment combination of AFI and FFI with 100% ET<sub>c</sub>, and 80% ET<sub>c</sub> levels were 50%, and 60% of total net volume of irrigation water applied respectively. Whereas CFI with 80% obtained was 20.0%. According to Shahnazari *et al.* (2007) comparative report of full irrigation with partial root drying for field grown potato, partial root drying treatments saves 30% of water which increases water use efficiency of the crop.

The optimum seasonal irrigation requirement was found to be 497.8 mm for every furrow irrigation method. For AFI and FFI, 248.9 mm of water was needed throughout the growing season of potato tuber (Table 3).

According to Doorenbos and Kassam (1997) for maximum yields, the crop water requirement (CWR) of potato for a 120 to 150 day crop growth is 500 to 700 mm depending on climate. Amount of water applied for every furrow irrigation treatment was agreed to some extent with the minimum water requirement stated previously.

### **Effect of Irrigation Methods and Irrigation water levels on yield of potato tuber**

The yield collected from each treatment was further differentiated to total yield, marketable yield and unmarketable yields. (Table 4) shows average tuber yield in terms of total tuber yield and marketable yield collected from each irrigation methods.

Table 4. Effect of Irrigation method and Irrigation level on potato yield and WUE

Irrigation Method (IM)	MY (t ha <sup>-1</sup> )	TY (t ha <sup>-1</sup> )	WUE (kg m <sup>-3</sup> )
AFI	24.84 <sup>b</sup>	30.51 <sup>b</sup>	13.61 <sup>a</sup>
FFI	24.18 <sup>b</sup>	29.00 <sup>c</sup>	12.97 <sup>b</sup>
CFI	31.51 <sup>a</sup>	33.49 <sup>a</sup>	7.98 <sup>c</sup>
S.Em±	0.46	0.17	0.05
CV	2.97	0.93	0.77
LSD (5 %)	1.81	0.67	0.20
Irrigation Level (IL)			

100% ET <sub>c</sub>	30.37 <sup>a</sup>	34.01 <sup>a</sup>	11.25 <sup>a</sup>
80% ET <sub>c</sub>	23.32 <sup>b</sup>	29.26 <sup>b</sup>	11.79 <sup>a</sup>
S.Em±	0.26	0.22	0.11
CV	1.68	1.22	1.59
LSD (5 %)	1.58	1.35	0.35

WUE = Water Use Efficiency, AFI = Alternate Furrow Irrigation, FFI = Fixed Furrow Irrigation, CFI = Conventional Furrow Irrigation, CV = coefficient of variation, LSD = Least significant difference, S.Em = Standard error of mean

### Marketable tuber yield (t ha<sup>-1</sup>)

Analysis of variance (Table 4) showed that marketable tuber yield was significantly ( $P < 0.05$ ) affected by irrigation methods (IMs) and irrigation levels (IL). The largest mean value of yield 31.51 t ha<sup>-1</sup> was produced under CFI, but statistically the yield recorded by AFI and FFI were not significantly different. Accordingly marketable tuber yield was influenced by Irrigation application levels; the average potato yield perceived by 100% ET<sub>c</sub> was 30.37 t ha<sup>-1</sup> and 23.32 t ha<sup>-1</sup> under 80% ET<sub>c</sub>. The lower marketable tuber yield was that received the least water. These results are in agreement with reports that water stress slows the vegetative development and reduces tuber yield (Kumar *et al.*, 2003 and Jensen *et al.*, 2000).

### Total tuber yield (t ha<sup>-1</sup>)

Analysis of variance (Table 4) showed that total tuber yield was significantly ( $P < 0.05$ ) affected by irrigation methods (IMs) and irrigation levels (IL). The largest mean value of 33.49 t ha<sup>-1</sup> was produced by CFI, and also the total yield of AFI and FFI were significantly different ( $P < 0.05$ ). The total yield recorded for AFI and FFI were (30.51 t ha<sup>-1</sup> and 29.00 t ha<sup>-1</sup>) respectively. The total tuber yield was nearly the same in both (AFI and FFI). Accordingly total tuber yield was influenced by irrigation application levels; the average total tuber yield obtained by 100% ET<sub>c</sub> was 34.01 t ha<sup>-1</sup> and 29.26 t ha<sup>-1</sup> by 80% ET<sub>c</sub> irrigation levels.

Liu *et al.* (2006b) found no difference in potato tuber yield between full irrigation (100% ET<sub>c</sub>) and PRD (70% of water applied to full irrigation from tuber initiation to maturity) in a field experiment, which suggest that PRD could be an effective strategy to improve WUE while sustaining yields provided PRD is optimized in terms of the timing of application and shifting and volume of irrigation water (Shahnazari *et al.*, 2008).

### Combined effect of Irrigation methods and Irrigation water Levels on tuber yield

From (Table 5) the interaction data of marketable yield and total tuber yield had significant effect ( $P < 0.05$ ) due to irrigation method (IM) and irrigation level (IL) and water use efficiency was not significantly affected.

Table 5. Interaction effect of Irrigation Systems and Irrigation Level on potato yield

Interaction (IS x IL)	MY (t ha <sup>-1</sup> )	TY (t ha <sup>-1</sup> )	WUE (kg m <sup>-3</sup> )
AFI x 100% ET <sub>c</sub>	30.01 <sup>b</sup>	34.22 <sup>b</sup>	13.75 <sup>a</sup>
AFI x 80% ET <sub>c</sub>	19.67 <sup>d</sup>	26.80 <sup>d</sup>	13.46 <sup>ab</sup>
FFI x 100% ET <sub>c</sub>	27.68 <sup>c</sup>	31.69 <sup>c</sup>	12.73 <sup>c</sup>
FFI x 80% ET <sub>c</sub>	20.68 <sup>d</sup>	26.30 <sup>d</sup>	13.21 <sup>bc</sup>
CFI x 100% ET <sub>c</sub>	33.41 <sup>a</sup>	36.12 <sup>a</sup>	7.2 <sup>e</sup>
CFI x 80% ET <sub>c</sub>	29.61 <sup>bc</sup>	34.69 <sup>ab</sup>	8.71 <sup>d</sup>
S.Em $\pm$	0.47	0.44	0.18
CV	3.06	2.40	2.72
LSD (5 %)	2.14	1.26	0.49

### Total potato tuber yield (t ha<sup>-1</sup>)

As indicated from the result the difference observed among irrigation methods as combined with irrigation levels in terms of total tuber yield was statically significant ( $P < 0.05$ ) effect (Table 5). However, total tuber yield was nearly the same in both (CFI and AFI) irrigation methods at full irrigation application (100% ET<sub>c</sub>); whereas total depth of water applied under every furrows irrigation was almost double as compared with that of applied under alternate furrow irrigation. The maximum tuber yield was 36.12 t ha<sup>-1</sup> at full irrigation application under CFI. Similar yield of 34.22 t ha<sup>-1</sup> was obtained by AFI method at full irrigation application. Good yields under irrigation of a crop of about 120 days in the temperate and subtropical climates are 25 to 35 t ha<sup>-1</sup> fresh tubers (Doorenbos and Kassam, 1979). Alternate furrow irrigation method produced total tuber yield of 33198 kg/ha which showed insignificant difference as compared with that obtained under every furrow irrigation (33369 kg/ha) (Adisu, 2018).



Figure: 3. Potato tuber at planting and maturity stage

Therefore, by implementing alternative furrow irrigation technique at full irrigation level, almost the same tuber yield was obtained comparing with every furrow irrigation method. This result agreed with outcome obtained by (Ahmadi, *et al.*, 2010) conclude that alternate furrow irrigation (AFI) or partial root-zone drying (PRD) can increase water productivity with no or minor yield loss.

The result also agreed with the outcome reported that alternate furrow irrigation or partial root-zone drying (PDI) saved irrigation water compared to every furrow irrigation while maintaining similar tuber yield with every furrow irrigation.

Even though, fixed furrow irrigation method saves water it is not appropriate method to meet crop water requirement as per growth stage of the crop and yield was reduced significantly. The minimum tuber (26.30) t ha<sup>-1</sup> was recorded at FFI method with 80% ETC irrigation level. This result agrees with outcome obtained by Shocket *et al.* (2013) conclude that improper irrigation depth and frequency can substantially reduce yields by increasing the proportion of rough, distorted tubers.

### **Effect of Irrigation methods and Irrigation water Levels on Water Use Efficiency**

Water Use Efficiency (WUE) sometimes called water productivity was expressed as the ratio of tuber yield at harvest to the water applied during growing season. Decreasing irrigation water application results in an increase in crop water productivity and the reverse is also true. Treatments with lower yield due to less water application had higher water use efficiency.

(Table 4) showed that WUE was significantly ( $P < 0.05$ ) affected due to irrigation methods (IMs) and not significantly affected by irrigation levels (IL). The largest mean value of  $13.61 \text{ kg m}^{-3}$  was recorded by AFI, and also that of FFI and CFI were ( $12.97$  and  $7.50$ )  $\text{kg m}^{-3}$  respectively. Water productivity was nearly the same in both AFI and FFI due to less irrigation water application. The result indicated that higher yield treatments had low water use efficiencies.

Water use efficiency was not significantly affected by the combination of irrigation methods (IM) and Irrigation levels (IL). The highest mean value  $13.75 \text{ kgm}^{-3}$  of WUE was recorded at AFI with full irrigation application and the minimum mean value  $7.26 \text{ kgm}^{-3}$  was obtained under CFI with full irrigation application (Table 3.5). The highest mean irrigation production efficiency of  $15.67 \text{ kg/m}^3$  is recorded when crop growing season is applied at 50% of irrigation schedule, because yield reduction is less as compared with seasonal water applied.

The higher mean value of WUE obtained under AFI was related to lower amount of water applied with uniform lateral movement in crop root zone and minor tuber yield reduction obtained under this method. The reason of having more water productivity (WP) and minor yield reduction for AFI could be related to better distribution of water in root zone in both sides of the ridge that increases water and fertilizer uptakes by plant.

This result indicated that AFI is appropriate to increase water productivity by applying less irrigation water for potato production which supports the outcome obtained by (Saeed *et al.*, 2007) using alternate furrow irrigation or partial root zone drying (PDI) higher water productivity (WP) and even better fruit quality can be produced.

WUE obtained between AFI and FFI was statistically non-significant. The same amount of irrigation water was applied for alternate furrow and fixed furrow irrigation techniques. However, alternative drying of root zone under alternate furrow irrigation method showed higher water productivity than fixed drying of root zone under fixed furrow irrigation method. This is due to uniform water distribution between ridges in alternate furrow than fixed furrow irrigation. Uniform water distribution between ridges in alternate furrow irrigation method enhanced root growth and improved nutrient uptake of crop which increases the yield than fixed furrow irrigation method. The results of this study are in close agreement with Wang *et al.* (2009) conclude that alternative furrow irrigation enhanced root growth and increased nutrient uptake of the crop. WUE value obtained was large for AFI and small for CFI at 100%  $\text{ETc}$  (Figure 1).

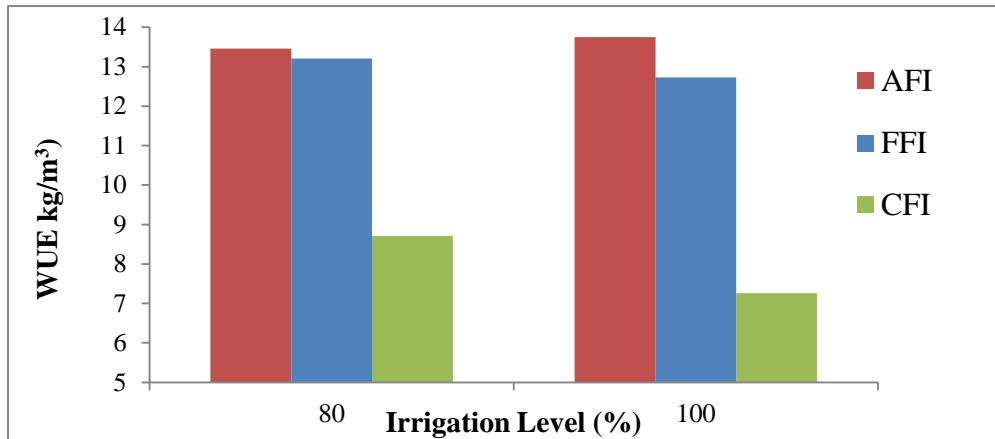

Fig 1. Irrigation level versus WUE

### Water supply–yield relationship

Water supply–yield relationship is also known as water production functions shows that, as the amount of irrigation water level increases yield production functions also increased (Figure 2). The slope of the regression line ( $R^2 = 1$ ) indicates that the increment of irrigation water level increases tuber yield. Large application of irrigation water for CFI increase yield as compared with other method but consumes large water.

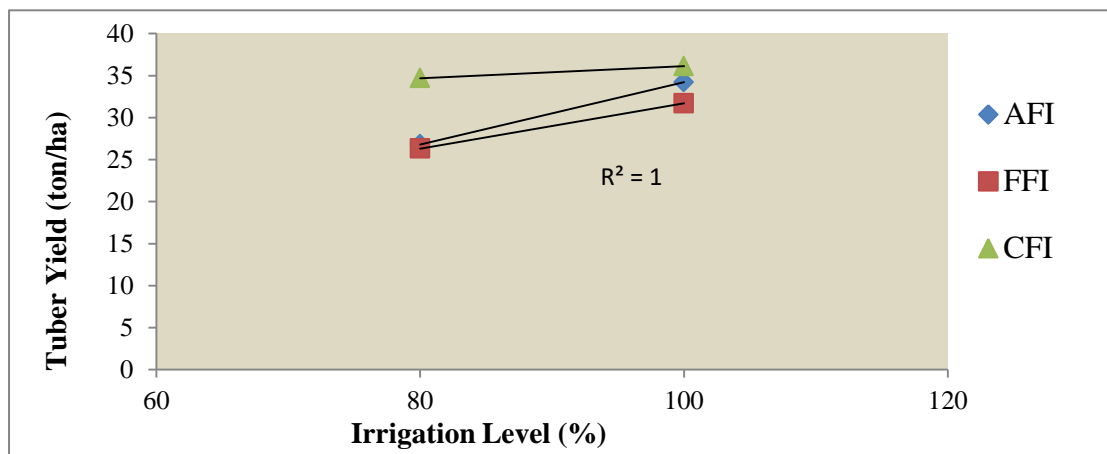

Figure 2. Irrigation water level versus Potato tuber yield

As shown in (Figure 3) below, if insufficient water is applied during the crop cycle the crop will not fully develop resulting in low quality of yield then water use efficiency is lowered.

Crop yield and water use efficiency can be increased if sufficient amount of water is added and also as the type of furrow method varies the yield and water production also varies. CFI gives highest yield and water production following AFI and FFI. Alternate furrow irrigation gives optimum yield and water production at full irrigation application.



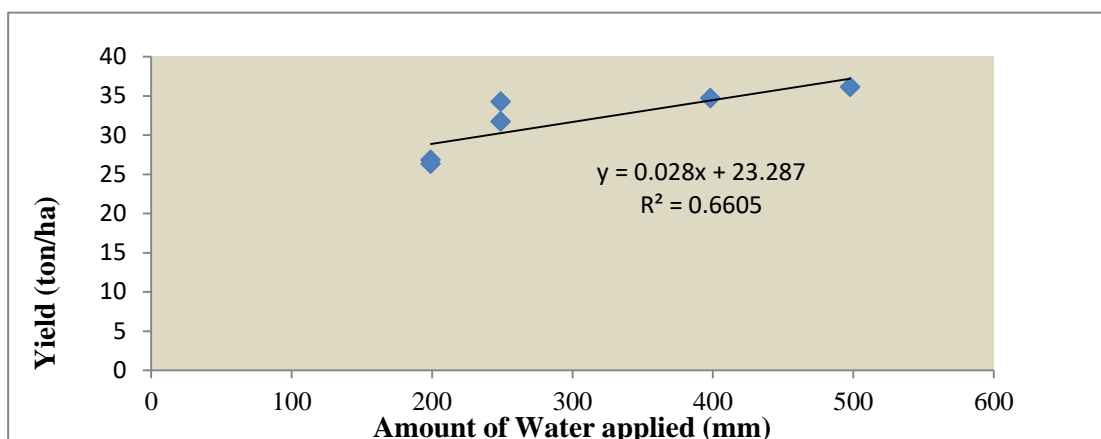

Figure 3. Irrigation water supplied versus tuber yield

As the amount of irrigation water applied increased for CFI the yield also increased, but high water productivity were gained in AFI and FFI system without significantly affecting the yield. The yield and water applied in three furrow irrigation system is leaner that means as the amount of water increased the yield increases. The comparison in (Figure 3) shows that there is a linear relationship between amounts of water applied and tuber yield obtained ( $R^2 = 0.6605$ ). The slope of the regression line which indicates the increment of tuber yield for an increase of irrigation water application is very low, because increasing unit application of water increase yield to certain limit and will finally stagnate and decrease.

Table 6. Water production function according to applied irrigation water

Treatments	Applied water (mm)	Actual yield (t/ha)	Water production function	$r^2$	Maximum yield (t/ha)
AFI x 100% ETc	248.9	34.22			30.26
AFI x 80% ETc	199.12	26.8			28.86
FFI x 100% ETc	248.9	31.69	$Y = 0.028W + 23.287$	0.6605	30.26
FFI x 80% ETc	199.12	26.3			28.86
CFI x 100% ETc	497.8	36.12			37.23
CFI x 80% ETc	398.24	34.69			34.44

As indicated in (Table 7), the result showed that the minimum yield reduction 3.96% was from CFI 80% ETc. But it consumes large amount of water. AFI x 100% ETc result in yield reduction of 5.26% correspondingly saves 50% water from the required amount of gross irrigation. Accordingly, additional area able to be irrigated with saved water. It clearly seen that the value of net yield generated was not influenced only by water applied but also furrow irrigation methods. The volume of water needed to irrigate one hectare area in CFI system is

enough to irrigate two hectare area of land in AFI system. So, when the area to be irrigated becomes double in AFI system using the saved volume of water, the yield obtained also becomes double.

Table 7. Extent of saved water and yield reduction

Treatment	Total Yield (tha <sup>-1</sup> )	Yield Reduction (%)	GIrr (mm)	water saved (mm)	Water saved (%)
AFI x 100% ETc	34.22	5.26	248.9	248.9	50
AFI x 80% ETc	26.8	25.80	199.12	298.68	60
FFI x 100% ETc	31.69	12.26	248.9	248.9	50
FFI x 80% ETc	26.3	27.19	199.12	298.68	60
CFI x 100% ETc	36.12	-	497.8	-	-
CFI x 80% ETc	34.69	3.96	398.24	99.56	20

### Potato tuber yield response to water

The crop yield response factor gives an indication of whether the crop is tolerant of water stress. A response factor less than unity indicates a crop is more tolerant to water deficit, and recovers partially from stress, exhibiting less than proportional reductions in yield with reduced water use. The steeper the slope (i.e. the higher the  $K_y$  value), the greater the reduction of yield for a given reduction in evapotranspiration because of water deficits in the specific period (FAO, 2012). The yield response factor was affected by irrigation method and irrigation level. From (Table 8), the result reveal that the lowest  $K_y$  (0.33) indicates there is lower reduction of yield of potato tuber due to flat slope ( $r^2 = 0.64$ ).

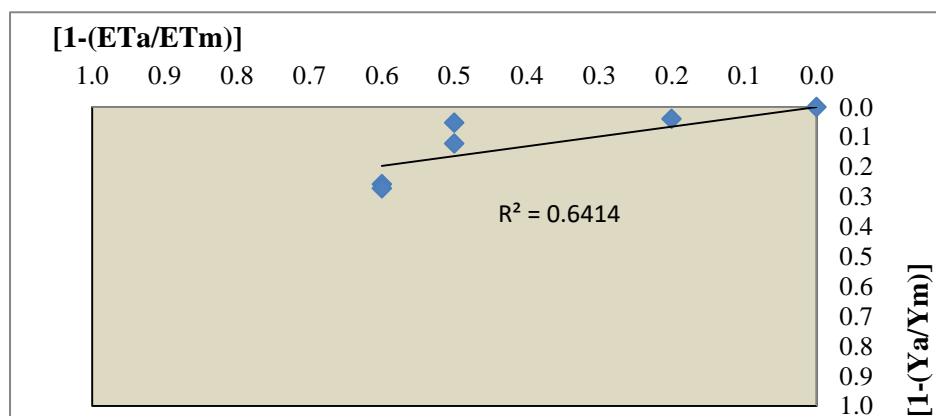

Figure 4. Linear water production functions for potato water deficits

## Economic Water Productivity

The field price of potato during the harvesting season 12 Birr kg<sup>-1</sup> and 3.8 Birr m<sup>-3</sup> value for water was taken (Jansen *et al.*, 2007). All the total costs were subtracted from gross benefit to obtain net benefit. Adjusted yield was multiplied by field price to obtain gross field benefit of tuber.

Table 8. Partial budgeting MRR and B/C analysis for economic potato production

Treatments	TC (ETB/ha)	UTY (kg/ha)	ATY (kg/ha)	GB (ETB/ha)	NB (ETB/ha)	B/C	MRR (%)
T <sub>1</sub>	7,565.66	34,220	30,798	369,576	362,010.34	47.85	
T <sub>2</sub>	6,052.53	26,800	24,120	289,440	283,387.47	46.82	5,196.03
T <sub>3</sub>	7,565.66	31,690	28,521	342,252	334,686.34	44.24	3,390.24
T <sub>4</sub>	6,052.53	26,300	23,670	284,040	277,987.47	45.93	3,747.12
T <sub>5</sub>	15,131.33	36,120	32,508	390,096	374,964.67	24.78	1,068.17
T <sub>6</sub>	12,105.06	34,690	31,221	374,652	362,546.94	29.95	410.33

TC= Total cost, UTY= Unadjusted total yield, ATY= Adjusted total yield, GB= Gross benefit, NB =Net benefit, B/C = Benefit cost ratio and MRR= Marginal Return of Rate

The detail evaluation of the economic analysis of treatments has shown that there was increasing trend of net benefit (NB) for increase in water application level (Table 8). It is clear that water saving at high application level is very low, though CFI treatment (T<sub>5</sub>) has the highest NB.

The extra income which can be obtained from unit increment in investment cost described as marginal rate of return (MRR). The highest MRR was 5,196.03% obtained at T<sub>2</sub>. This means that for every 3.8 birr invested on applied water of 199.12mm, farmers can expect to recover 3.8 birr and obtained additional of 51.96 birr. This shows that T<sub>2</sub> can be the most preferable type of irrigation treatment to all other tested irrigation treatments as it can generate more profit per extra addition investment in water limited areas. The highest B/C ratio (47.85, and 46.82) was obtained from T<sub>1</sub> and T<sub>2</sub> respectively (Table 8). This result generally revealed that AFI gave high net income as compared to the other furrow methods for furrow irrigated total tuber yield of potato.

## **Conclusions and Recommendations**

### **Conclusions**

In this study, an attempt was made to evaluate the effect of potato tuber to furrow irrigation system and irrigation water level at Oda Sirba scheme, Bokoji climatic condition. The aim was to enhance potato production, to investigate the effect of alternate, fixed and conventional furrow irrigation systems on yield and water productivity of and to identify the level of deficit irrigation for achieving optimum crop yield.

The experimental treatments include three irrigation systems, viz., the Alternate furrow irrigation, fixed furrow irrigation, conventional furrow irrigation and one irrigation application levels, viz., 80% ETc, and a control irrigation of 100% ETc application. The experimental design was a split plot design with three replications.

The result obtained reveals that 50% water was saved in AFI and FFI as compared to FFI method. When less irrigation was applied as in alternative furrow irrigation (AFI) system, the smallest grain yield reduction was happened. In fact, this yield reduction was not statistically significant with CFI treatments. Even though, the highest yield was obtained at CFI at full irrigation application it consumes large amount of water. AFI at full irrigation application give similar yield as that of CFI. The highest WUE was obtained at AFI with 100% ETc.

The yield of potato tuber is increased by increasing the amount of water up to the optimal consumption level, and if irrigation water is used more than crop water requirement, further run off over irrigation will cause the reduction of yield and loss of water.

Therefore, it can be concluded that increased water saving and associated water productivity through the use of 100% ETc with AFI, can solve problem of water shortage which improve WUE without significant reduction of yield. AFI system at full irrigation application appears to be a promising alternative for water conservation and labor saving with negligible reduction in yield.

### **Recommendations**

Based on the findings obtained from the experiment, the following recommendations are made:

- Irrigation water management through deficit irrigation strategies should be declared with appropriate irrigation level restriction during growth stages to achieve optimum yield and save water.
- Suggesting of practicing irrigation with different irrigation method save irrigation water and it increases frequency of cultivation, additional command area to be irrigated or use for other purpose of income generation.
- Thus, it is recommended that all possible efforts made to introduce the technology to the farming community since the use of alternate and fixed furrow irrigation method saves reasonable amount of water without affecting the production in moisture deficit areas using appropriate varieties of a given crop. Nonetheless, further studies should be made to identify potentially suitable crops for alternate, fixed and conventional furrow irrigation method.

## References

- Adane, H., Miranda, P. M., Meuwissen, A. T., Willemien, J. M., Lommen, A. O. L., Admasu, T., & Paul, C. S. 2010. Analysis of seed potato systems in Ethiopia. *American Journal of Potato Research*, 87(6), 537–552. <https://doi.org/10.1007/s12230-010-9164-1>
- Adisu Tadese Eba, 2018. The Impact of Alternate Furrow Irrigation on Water Productivity and Yield of Potato at Small Scale Irrigation, Ejere District, West Shoa, Ethiopia. *J Plant Sci Agric Res.* (2). 2:16.
- Ahmadi, S.H., Andersen, M.N., Plauborg, F., Poulsen, R.T. and Jensen, C.R. 2010. Effects of irrigation strategies and soils on field grown potatoes: Yield and water productivity. *J Agric Water Manag* 97:1923-1930.
- Ali, M.A., Hoque, M.R., Hassan, A.A. and Khair, A. 2007. Effects of deficit irrigation on yield, water productivity and economic return of wheat. *J Agric Water Manag* 92:151-161.
- Awulachew, B., Merrey, D. J., Kamara, A. B., Van Koopen, B., De Vries, Penning, F. and Boelle, E. 2005. Experiences and opportunities for promoting small-scale/micro irrigation and rainwater harvesting for food security in Ethiopia. IWMI Working Paper 98. IWMI, Colombo, Sirilanka
- Awulachew, B., Teklu, E. and Regasa, E. N. 2010. Irrigation potential in Ethiopia constraints and opportunities for enhancing irrigation potential in Ethiopia constraints and opportunities for enhancing the system. IWMI, Colombo. Sirilanka.
- Awulachew, B., Yilma, D., Loulseged, M., Loiskand, W., Ayana, M. and Alamirew, T. 2007. Water Resources and Irrigation Development in Ethiopia. IWMI Working Paper 123. Colombo, Sirilanka.
- Booher, L. J., 1974. Surface irrigation. FAO, Agricultural Development Paper 95. FAO, Rome.
- Brouwer, C., Goffeau, A. and Heibloem, M. 1985. Irrigation Water Management: Training Manual No. 1- Introduction to Irrigation. Food and Agriculture Organization of the United Nations, Rome, Italy.
- Cass, A. 1998. Measuring and managing chemical impediments to growth. *Australian Grape grower & Winemaker*. 415, 13–16.
- CIMMYT (International maize and wheat improvement center). 1988. From Agronomic Data to Farmer Recommendations: An Economics Training Manual. Completely Revised Edition, DF, Mexico.
- CIP (International Potato Centre). 2017. *Harnessing potato and sweet potato's power for food security, nutrition and climate resilience international, annual report*. International Potato Centre.
- CSA (Central Statistical Agency). 2016. *Agricultural sample survey: Area and production of major crops*. Central Statistical Agency.
- Doorenbos, J. and Kassam, A. H. 1979. Yield response to water. FAO Irrig. Drain. Paper No.33. FAO, Rome, Italy.

- Enchalew, B., Gebre, S. L., Rabo, M., Hindaye, B., Kedir, M., Musa, Y. and Shafi, A., 2016. Effect of Deficit Irrigation on Water Productivity of Onion (*Allium cepa.*) under Drip Irrigation. *Irrigation & Drainage Systems Engineering*. Ethiopia, 5(3): 2168-9768
- FAO (Food and Agricultural Organization), 2001. AQUASTAT-FAO's Information systems on water and agriculture. <http://www.wca.infonet.org/cds static/en/aqua-stat fao information system water> Ethiopia 569-14376 (online 3/24/05).
- FAO (Food and Agriculture Organization of the United Nations. 2009. *Sustainable potato production, Guidelines for developing countries*. FAO, Rome, Italy.
- FAOSTAT. 2020. *Statistical database*. Food and Agricultural Organization of United Nations.
- Gebremedhin, W., Endale, G., & Lemaga, B. 2008. Potato variety development. In W. Gebremedhin, G. Endale, & B. Lemaga (Eds.), *Root and tuber crops: The untapped resources* (pp. 15–32). Ethiopian Institute of Agricultural Research.
- Graterol, Y. E., Eisenhauer, D. E. and Elmore, R. W. 1993. Alternate furrow irrigation for soybean production. *Agricultural Water Management*, 24: 133-145
- Hodges, M. E., Stone, J. F., Garton, J. E. and Weeks, D. L. 1989. Variance of water advance in wide spaced furrow irrigation. *Agricultural Water Management* 16: 5-13
- IWMI (International Water Management Institute). 2010. Irrigation potential in Ethiopia. Constraints and opportunities for enhancing the system. International Water Management Institute.
- Jensen, M. E. 1968. Water consumption by agricultural plants. In: Kozlowski T.T. (ed.), *Water deficits in plant growth*, Academic Press, New York 2:1–22.
- Kang, S., Liang, Z., Pan, Y. and Zhang, J. 2000. Alternate furrow irrigation for maize production in an arid area. *Agricultural Water Management* 45: 267-274
- Kefelegn, H., Chala, A., Kassa, B., & Tiwari, P. K. 2012. Evaluation of different potato variety and fungicide combinations for the management of potato late blight (*Phytophthora infestans*) in Southern Ethiopia. *International Journal of Life Sciences*, 1(1), 8–15. <http://www.crdeep.org>
- Liu, F., Shahnazari, A., Andersen, M. N., Jacobsen, S. E. and Jensen, C.R. 2006. Physiological responses of potato (*Solanum tuberosum* L.) to partial root-zone drying: ABA signaling, leaf gas exchange, and water use efficiency. *J Exp Bot* 57: 3727-3735.
- Mati, B. M., 2012. *In-Field Water Management in Irrigated Agriculture: Adaptable Best Practices*. Training Manual No. 8. Nile Basin Initiative (NBI), Nile Equatorial Lakes Subsidiary Action Program (NELSAP), Regional Agricultural Trade and Productivity Project (RATP)
- OESO (Oromia Economic Study Office), 1999. Annual Report of Regions for Investment.
- Saeed, H., Grove, I.G., and Kettlewell, P.S. and Hall, N.W. 2007. Potential of partial root zone drying as an alternative irrigation technique for potatoes
- Shock, C.C., Pereira, A., Wang, F.X., Flock, R. and Eldredge, E. 2013. Successful irrigation scheduling of potato. *Sustainable Agriculture Techniques*. Oregon State University, USA. pp. 1-8.
- Stone, J. F, and Nofzger, D. L. 1993. Water use and yields of cotton grown under wide spaced furrow irrigation. *Agricultural Water Management* 24: 27-38
- Tekalign, T., & Hammes, P. S. 2005. Growth and productivity of potato as influenced by cultivar and reproductive growth I, stomatal conductance, rate of transpiration, net photosynthesis and dry matter production and allocation. *Scientia Horticulture Journal*, 105(1), 13–27. <https://doi.org/10.1016/j.scienta.2005.01.029>
- Wang, H., Liu, F., Andersen, M.N. and Jensen, C.R. 2009. Comparative effects of partial root-zone drying and deficit irrigation on nitrogen uptake in potatoes (*Solanum tuberosum* L.). *J IRRIGATION SCI*. 27: 443-448.
- Zhang, J., Kang, S., Liang, Z., Pan, Y. Z., Shi, P., Pan, Y. H., Liang, Z. S. and Hu, X. T. 2000. Soil water distribution, uniformity and water use efficiency under alternate furrow irrigation in arid areas. *Irrig. Sci*. 19: 181-190.

# Design, construction and evaluation of runoff water harvesting Pond for smallholder farming

Bayan Ahmed\* and Fikadu Gemedu

*Oromia Agricultural Research Institute, Asella Agricultural Engineering Research Center  
P.O Box 6, Asella, Oromia, Ethiopia. \*Correspondent author email: bayahm@gmail,.com*

## Abstract

*Rainfall shortage and variability constrain crop production of smallholder farmers in Ethiopia is the main problem. For this supplementary irrigation by run off harvesting is strategic pathway to reduce poverty in rural drought prone areas for enhancing agricultural productivity and boosting farm income. For this, this study is conducted to Design, construction and evaluation of runoff water harvesting Pond for supplementary irrigation to addressing inherent crop failures under the rain fed agriculture due to mainly erratic rainfall. For this design climatic and soil data were input to determine seasonal crop water requirement (CWR) of onion and evaporation loss of water from water surface. Then the performances of water harvested verses area irrigate were evaluated. To make this study more economical the water harvester capacity decreed by two fold and water harvesting made at two times. Seasonal volume crop water requirement (CWR) of onion for farm area 2500 m<sup>2</sup> and evaporation loss of water from water surface of 121 m<sup>2</sup> and total volume of seasonal water need were 382.05,53.38 and 435.43 m<sup>3</sup> respectively. The geo-membrane laminated water harvester that has capacity of 223 m<sup>3</sup> was designed and constructed. From on field performance shows, this volume of water harvested twice can irrigate 0.25ha by supplementary irrigation using water saving irrigation technology (treadle pump) by over showering and was produced 4.2 tone/ha. The investment, operation and production costs were 63116, 1125 and 6675 ETH birr respectively. The total cost was 70,916 birr and the growth return of 0.25ha was 15,750 birr/year (1050kg\*15 birr/kg). This show the farmer can return 22.21% of their investment cost. So it is recommended to the government and non-government to initiate the farmers at lower stream of the catchment to harvest run off water and use for supplementary irrigation to increase their income.*

**Key words:** *Rain water harvesting, runoff, desighn, pond*

## Introduction

Agriculture is the backbone of Ethiopian economy. It accounts for a little over 50 percent of the GDP, 90 percent of the total export revenue and employs 85 percent of the country's labor force and the main income generating sector for the majority of the rural population. It provides raw materials for more than 70% of the country's industries (CSA, 2013). The dependency of farming system on rain fed agriculture has made the Ethiopia's agricultural

economy extremely exposed to weather and climate effects (Conway and Schipper, 2011). The failure of rain and the occurrence of drought or consecutive dry spells during the growing season lead to crop failure. This in turn results in food shortage and contributes to food insecurity and reduced income generation from agricultural products sale (Teshome *et.al*, 2010).

Rain-fed agriculture in Ethiopia is suffering from moisture stress which is a major limiting factor for successful crop production. Many of Ethiopian smallholders depending on rain-fed agriculture are food insecure. In many places, the amount of rainfall and the duration of rainy season are highly variable frequently resulting in low crop yields and associated low incomes. Because of large differences in rainfall distribution between years and within years coupled with short rainy seasons, rain-fed agriculture is very susceptible to water shortage. As the scarcity of water is rapidly increasing, everyday particularly during the summer season the demand for water also substantially increases (Teweldebrihan, 2014).

Water harvesting can best be described as all activities to collect available water resources, temporarily storing excess water for use when required, especially in periods of drought or when no perennial resources are available. The starting point is the collection of natural water resources from rainwater, fog, runoff water, groundwater or even waste water, which otherwise would have escaped. World water resources are facing dramatic changes as a result of global climate change, high water demands, population growth, industrialization and urbanization.

To respond to water scarcity and unequal distribution, small-scale water harvesting techniques provide a direct solution, especially in rural and drought-prone areas. Local storage of water is increasingly important for ensuring water availability and food security for rural and urban populations, especially in developing countries. This is particularly the case in areas with dry seasons where perennial rivers and fresh groundwater are not available or difficult to reach (NWP, 2007).

The on-farm research in semi-arid locations in Kenya (Machakos district) and Burkina Faso (Ouagouya) during 1998-2000 indicates a significant scope to improve water productivity in rainfed agriculture through supplemental irrigation, especially if combined with soil fertility management. The results were more promising on soils with higher water holding capacity on which crops seem to cope better with intra-seasonal dry spells (Fox and Rockstrom, 2000).



In Ethiopia, promotion and application of rainwater harvesting techniques as alternative interventions to address water scarcity were started through government initiated soil and water conservation programmers.

Today, smallholder farmers feel increasing vulnerability to water shortages; consequently, the demand for water storage is rising. The more unreliable the natural supply becomes, the greater the need for water storage. With stored water accessible, farmers feel less vulnerable to climatic fluctuations, and thus are encouraged to invest more in agricultural inputs and equipment to improve their farming productivity.

One of the main pillars of the Ethiopian government food security strategy is the development and implementation of water harvesting schemes mainly in the drought prone and chronically drought affected areas of the country. But most of farmers have not trained to harvest water and some of water harvester constructed was not depend on catchment run off and silt protector is not properly designed for this reason most of water harvested is filled by sediment.

Therefore to minimize the negative impacts of runoff water generated from catchment area (erosion, flooding) and optimizing its benefits as supplementary source for addressing inherent crop failures under the rainfed agriculture due to mainly erratic rainfall this study were conducted with the objective of design and construction and evaluation of runoff water harvesting structure on onion crops.

## **Material and methods**

### **Description of the study area**

The study was conducted at Dodola district of Keta Barendkebele. The crop used for this study was red onion and treadle pump was used to transport water from harvester to irrigating field by over showering. The field area used for evaluation was 2500 m<sup>2</sup>.

### **Data collection**

The primary and secondary were collected. The data collected were farmers' estimations on direction of water flow, meteorological data; laboratory work was done to assess the soil physical and chemical characteristics.

### **Soil data**

To determine the soil texture disturbed soil samples and for bulk density, moisture content at field capacity (FC) and permanent wilting point (PWP) undisturbed soil samples were collected by core sampler and auger from two depths 0-30cm and 30-60cm at three points diagonally of the experimental site and were taken to laboratory for analysis.

### **Climatic data**

Necessary parameters, like minimum and maximum temperature, relative humidity, wind speed and daily sunshine hour 20 years of the study area were collected from National Meteorological Agency to determine mean daily reference evapotranspiration (ET<sub>o</sub>).

### **Irrigation Water Requirement**

CROPWAT version-8 was used and climatic and soil data were fed to calculate the reference evapotranspiration (ET<sub>o</sub>) of the study area. To determine it 20 year data from National Meteorological Station were used and feed to CROPWAT 8 software.

$$ET_c = ET_o \times K_c \quad (1)$$

Where: ET<sub>c</sub> = crop evapotranspiration (mm/day)

ET<sub>o</sub> = reference crop evapotranspiration (mm/day)

K<sub>c</sub> = crop coefficient

### **Soil Infiltration Capacity**

Infiltration rate was measured using double ring infiltrometer. The measurement was done at 15,30,45,60 minute intervals at randomly selected study site.

### **Run off collection**

Due to site selected at the tail of large catchment the volume of run off collected was fixed by field to irrigate depending on crop water requirement need. To collect run off the rectangular canal and silt trap was constructed and diverted from flooding tail point of catchment.

### **Sediment load analysis**

For sediment load determine, two methods were used and used for design water harvester volume of sediment (dead storage) determine. The first was during water harvest and second

was after water harvested. For the first option one liter of runoff sample was taken from the inlet and outlet of the silt trap.

### **Water loss/evaporation**

This lost water is referred to as consumed, because it is removed from the system. In some cases, this water consumption can be quite substantial. This will be calculated as sated by FAO (2015).

$$E = K_w * E_{To} \quad (2)$$

Where: E is water loss/evaporated,  $K_w$  is the coefficient for open water,  $E_{To}$  is reference ET for short Grass. FAO (1998) suggests a  $K_w$  value of 0.65 at initial and 1.25 at development of the crop.

### **Determination of the Storage Capacity of RWH Pond**

For determining volume of water harvester, sessional crop water and evaporation from surface water harvester and volume of sediment occupied was identified. Then truncated Square pyramid formula was used.

$$\text{Volume: } V = (a^2 + ab + b^2) h \quad (4)$$

$$\text{Lateral Area: } F = 2(a+b) \quad (5)$$

$$\text{Surface Area: } S = F + a^2 + b^2 \quad (6)$$

Where:  $b$  = the bottom surface of the pond

$a$  = top surface of the pond and

$h$  = the depth of the pond

### **Laminating and fencing**

To prevent seepage loss, surface area of water harvesting pond was calculated using equation (6) and fitting geo-membrane plastic of 0.5mm was laminated. The fence was constructed to prevent the interference of animals and children.

### **Performance of water harvested**

The performance of water harvested was evaluated by theoretical irrigating capacity and on farm irrigating capacity of harvester depending on climatic and soil of the area, volume of sediment occupied, silt trap efficiency and water productivity.

### **Volume sediment occupied**

The silt passed the silt trap and entered harvesters were determined by area method after water used.

### **Silt trap efficiency (STE)**

The silt trap efficiency of the reservoir is the ratio of sediment caught in the storage and total load entering with the runoff.

### **Water productivity (WP)**

Is the ratio of the physical yield of a crop (kg) and the amount of water consumed (m<sup>3</sup>), including both rainfall and supplemental irrigation (Arega, 2003).

$$WP = \frac{\text{Yeild}}{\text{Amount of water consumed}}$$

### **Economic Analysis**

Economic analysis was computed based on investment, operation and production cost of the experiment. The investment and operation cost was by adding material need for the contraction and cost of man power consumed during excavation and on field operation and production. The total gross return was obtained by multiplying yield with unit price of the product.

### **Statistical analysis**

The results were analyzed by descriptive statistically using Microsoft excel and compared averages result of parameters.

## **Results and Discussions**

### **Soil Physical and Chemical Properties**

The laboratory result of soil physical and chemical properties at study site is presented in Table 1. From this table, the soil texture was clay and average soil bulk density was 1.13 g / cm<sup>3</sup>. Field capacities (FC) and permanent wilting point (PWP) were 38.2 and 23.7 (%) respectively. The total available water (TAW) was 145 mm/m.

Table 1:- Soil physical and chemical property

Soil property	Results
Soil Particle size distribution	Sand (%) = 19 Silt (%) = 29 Clay (%) = 52
Texture	Clay
pH	5.8
EC	0.18
OC	2.26
OM	3.9
Bulk density (g/cm <sup>3</sup> )	1.32
FC (% Vol)	38.2
PWP (%Vol)	23.7
TAW (mm/m)	145
Infiltration rate (mm/hr)	8

### Reference Evapotranspiration and Crop Water Requirements

Table 2 shows daily and monthly reference evapotranspiration (ET<sub>o</sub>), effective rain fall and irrigation water requirements of onion crop at study area. This was used to determine volume of water harvested relation to area to irrigate. The minimum reference evapotranspiration was occurred 1.87 mm/day in December, maximum 4 mm/day in February and mean of 3.23 mm/day. The sessional reference evapotranspiration (ET<sub>o</sub>), effective rain fall and irrigation water requirements were 361.5, 107 and 254.6 mm respectively.

Table 2:- daily and monthly reference evapotranspiration (ET<sub>o</sub>), effective rain fall and irrigation water requirements of onion

Month	Decade	Stage	Kc coeff	ET <sub>c</sub> mm/day	ET <sub>c</sub> mm/dec	Eff rain mm/dec	Irr. Req. mm/dec
Nov	3	Init	0.5	1.88	18.8	3.7	5.7
Dec	1	Init	0.5	1.87	18.7	6.1	12.6
Dec	2	Deve	0.61	2.28	22.8	4.7	18.1
Dec	3	Deve	0.82	3.07	33.8	6.8	27
Jan	1	Mid	0.99	3.71	37.1	9.8	27.4
Jan	2	Mid	1	3.77	37.7	11.7	26
Jan	3	Mid	1	3.85	42.3	11.5	30.9
Feb	1	Mid	1	3.93	39.3	10.7	28.6
Feb	2	Late	1	4	40	10.6	29.4
Feb	3	Late	0.94	3.78	30.2	11.9	18.4
Mar	1	Late	0.85	3.44	34.4	12.8	21.6
Mar	2	Late	0.77	3.16	15.8	6.8	9
<b>Total</b>					<b>361.5</b>	<b>107</b>	<b>254.6</b>

Kc= Crop coefficient, ET<sub>c</sub> = Evapotranspiration of the crop

### Water loss/evaporation calculation

The loss of water from upper area of water body was estimated using the equation 2 throughout session. Then the volume of water lost was considered as consumed on design. From the table 3 below the volume of water lost due to evaporation from the surface of the body during crop growing season was 53.38 m<sup>3</sup> was calculated.

Table 3:- Water loss from water body of crop growing

Month	Average ETc (mm/dec)	Kw	Loss (mm)	Loss (m)	Area (m <sup>2</sup> )	Volume of water (m <sup>3</sup> )
Nov	18.8	0.65	12.22	0.01	121	1.48
Dec	18.7	0.65	12.155	0.01	121	1.47
Dec	22.8	1.25	28.5	0.03	121	3.45
Dec	33.8	1.25	42.25	0.04	121	5.11
Jan	37.1	1.25	46.375	0.05	121	5.61
Jan	37.7	1.25	47.125	0.05	121	5.70
Jan	42.3	1.25	52.875	0.05	121	6.40
Feb	39.3	1.25	49.125	0.05	121	5.94
Feb	40	1.25	50	0.05	121	6.05
Feb	30.2	1.25	37.75	0.04	121	4.57
Mar	34.4	1.25	43	0.04	121	5.20
Mar	15.8	1.25	19.75	0.02	121	2.39
<b>Total</b>						<b>53.38</b>

### Design of water harvester

For determining volume of water harvester, sessional crop water and evaporation from surface water harvester and volume of sediment occupied. For determining volume of water harvester, sessional crop water and evaporation from water surface were 382.05 and 53.38 m<sup>3</sup> respectively. The total volume of water used for design of harvester was 435.43 m<sup>3</sup>

Table 4:- Total volume of water pond

Month	CWR (mm)	Irrigated area in (m <sup>2</sup> )	Volume of water need in (m <sup>3</sup> )	Volume of water loss in (m <sup>3</sup> )	Total volume of water in (m <sup>3</sup> )
Nov	5.7	1500	8.55	1.48	10.03
Dec	12.6	1500	18.9	1.47	20.37
Dec	18.1	1500	27.15	3.45	30.6
Dec	27	1500	40.5	5.11	45.61
Jan	27.4	1500	41.1	5.61	46.71
Jan	26	1500	39	5.70	44.7

Jan	30.9	1500	46.35	6.40	52.75
Feb	28.6	1500	42.9	5.94	48.84
Feb	29.4	1500	44.1	6.05	50.15
Feb	18.4	1500	27.6	4.57	32.17
Mar	21.6	1500	32.4	5.20	37.6
Mar	9	1500	13.5	2.39	15.89
<b>Total</b>			<b>382.05</b>	<b>53.38</b>	<b>435.43</b>

But 223 m<sup>3</sup> the harvester that have the bottom surface of 6 m top surface of 11 m and depth of 3 m the pond was designed and to make this study more economical the water harvester capacity decreed by two fold and water harvesting made at two times. It lateral surface area was laminated by 238 m<sup>2</sup> geo-membrane.

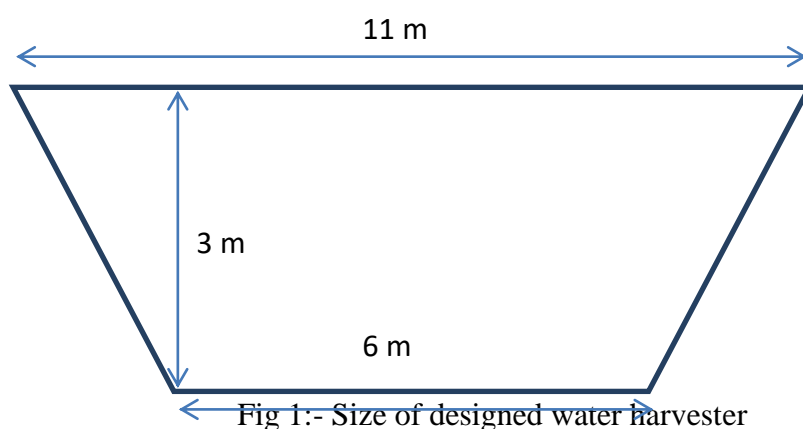

Fig 2:- Water harvester pond constructed

### Water productivity (WP)

The was calculated using yield of 4200kg /ha and sessional water requirement of 4500 m<sup>3</sup>/ha was 0.93kg/m<sup>3</sup>.

### Estimation of costs for a run off harvester with 223 m<sup>3</sup> capacity

The following Economic analysis was computed based on investment, operation and production cost of the experiment. The total investment, operation and production cost was 63,116 birr.

Table 5:- The investment cost of water harvesting pond

Materials	Quantity	Unit cost in birr	Total cost in birr
Excavation	223 m <sup>3</sup>	150	33,450
Geo-membrane plastic 0.5mm	238 m <sup>2</sup>	65	15,470
Geo-membrane binding	238 m <sup>2</sup>	42	9,996
Fence wire	36 kg	60	2160
Nail 3, 5,7,9	3 kg	30	90
Kanch	55 pcs	20	1100
Korkora	1 pcs	100	100
Daily lobar fence constriction	10	75	750
<b>Total cost</b>			<b>63,116</b>
<b>Operation/session</b>			
Water lifting by Treadle pump	15	75	1125
<b>Total</b>			<b>1125</b>
<b>Production for 0.25 ha</b>			
Land preparation	2 time	500	1000
Seed	Bed	800	800
Fertilizer	1.5 kunt	1500	2250
Cultivation	10	75	750
Chemicals			1500
Harvesting	5	75	375
<b>Total</b>			<b>6,675</b>
<b>Over all total cost</b>			<b>70,916</b>

### Net return cost

This capacity of harvester was irrigate 0.25 ha/year and its total cost was 70,916 birr. The growth return of 0.25ha was 15,750 birr (1050kg\*15 birr/kg). This show the farmer can return 22.21% of their investment cost.



## Conclusions and Recommendations

### Conclusions

Supplementary irrigation by run off harvesting is strategic pathway to reduce poverty in rural drought prone areas for enhancing agricultural productivity and boosting farm income.

For the study to Design, construction and evaluation of runoff water harvesting Pond for supplementary irrigation the climatic and soil data were input to determine seasonal crop water requirement of onion and evaporation loss of water from water surface.

From the result obtained the Seasonal volume of crop water requirement of onion for farm area  $2500 \text{ m}^2$  and evaporation loss of water from water surface of  $121 \text{ m}^2$  and total volume of seasonal water need to irrigate this area were  $382.05, 53.38$  and  $435.43 \text{ m}^3$  respectively and used for the design. The geo-membrane laminated water harvester that has capacity of  $223 \text{ m}^3$  (6 m bottom width and 11 m top width) was designed and constructed. Then the performances of water harvested verses area irrigate were evaluated. From on field performance shows, this volume of water harvested twice can irrigate 0.25ha by supplementary irrigation using water saving irrigation technology (treadle pump) by over showering and was produced 4.2 tone/ha.

### Recommendation

The extension team has work to initiate the farmers at lower stream of the catchment to harvest run off water and use for supplementary irrigation to increase their income.

### Reference

- Conway, D. and E.L.F. Schipper (2011), Adaptation to climate change in Africa: Challenges and opportunities identified from Ethiopia. *Global Environmental Change*, 21(1): p. 227-237.
- CSA (Central Statistical Agency). 2013. Revised Report on the 2012 / 2013 Private peasant holdings, meher season, area and production of major crops Survey. Statistical Bulletin 532. Addis Ababa: The Federal De
- FAO (Food and Agriculture Organization). 2015. Evaporation from artificial lakes and reservoirs.
- Fox, P., Rockstrom, J., 2000. Water harvesting for supplemental irrigation of cereal crops to overcome intra-seasonal dry spells in the Sahel. *Phys. Chem. Earth (B)* 25 (3), 289–296.
- GetachewAlem, 1999. Rain water harvesting in Ethiopia: an overview Netherlands Water Partnership (NWP, 2007). *Smart Water Harvesting Solutions*. Examples of innovative, low-cost technologies for rain, fog, runoff water and groundwater.in Stockholm, Sweden.
- Teshome, A., E. Adgo, and B. Mati, (2010), Impact of water harvesting ponds on household incomes and rural livelihoods in MinjarShenkora district of Ethiopia. *Ecohydrology& Hydrobiology*, 10(2): p. 315- 322.
- Teweldebrihan, M. D. 2014. Optimizing Intensified Runoff from Roads for Supplemental Irrigation: Tigray Region, Ethiopia, (April).

# Effect of Decision Variables on Irrigation Performances and Yield of Onion Crop at Bako Woreda, West Shewa, Ethiopia

\*Gudeta Genemo<sup>1</sup>, Teshome Seyoum<sup>2</sup> and Fantaw Abagez<sup>3</sup>

<sup>1</sup>Oromia Agricultural Research Institute, Bako Agricultural Engineering Research center, Bako

<sup>2</sup>School of Water Resources and Environmental Engineering, Haramaya University, Ethiopia

<sup>3</sup>Ethiopian Institute of Agricultural Research, Senior Irrigation and Drainage Engineering Researcher

\*Corresponding author e-mail: [4genemo@gmail.com](mailto:4genemo@gmail.com)

## Abstract

*Flow rate and Furrow length are the main furrow irrigation decision variables currently affecting the performance of furrow irrigation at the farm level. Improper selection of these variables makes over Irrigation which results in loss of crop yield and low irrigation efficiencies. The general objectives of this study was to investigate the effect of decision variables on irrigation performances and yield of onion, with specific objectives of analyzing the effect of flow rate and furrow length on irrigation performances and yield under onion crops. The field experiment was laid out factorial in randomized complete block design arrangement of three levels of flow rate (0.7, 0.98 and 1.3l/s) and three levels of furrow length (25, 35, and 50m) with three replication. For performance evaluation, Soil moisture content was determined by using the gravimetric method. Irrigation performance parameters such as application efficiency (Ea), storage efficiency (Es), distribution uniformity (DU), Christiansen's uniformity coefficient (UCC), deep percolation ratio (DPR), and onion yield were used for evaluation. The analysis of performance parameters indicated that the effect of furrow length and flow rate was highly significant ( $P<0.01$ ) on all performance indicators. The minimum and maximum values for Ea, Es, DU, UCC and DPR were 53.60 and 65.87%; 78.05 and 94.98%; 80.42 and 92.17%; 91.14%, 97.97%, 34.35% and 46.40%, respectively. The ranges of mean yield gained from furrow length and flow rate were 14.75 to 15.96ton/ha and 13.59 to 16.94ton/ha, respectively. The effect of furrow length and their interaction with flow rate on yield was not significant ( $p<0.05$ ). However, the flow rate showed a highly significant ( $p<0.01$ ) effect on the yield of onion. Therefore, In a soil that has clay loam texture, 0.6% furrow bed slope, and a furrow length of 50m it is suitable to use 1.3 l/s of flow rate for better onion yield, and irrigation efficiency.*

**Keywords:** decision variable, flow rate, furrow irrigation, Performance parameter

## Introduction

Agriculture is the main sector for the Ethiopian economy. However, agricultural production and its impact on the country's economy are closely linked with the occurrence and levels of precipitation fluctuations. The government has increased the emphasis on irrigated agriculture to mitigate the effect of rainfall variability and to enhance crop production and improved livelihood.

Despite its enormous potential to boost the country's economy irrigated agriculture is facing several problems. One of the major problems is the generally poor efficiency with which water resources have been used for irrigation. A large part of low irrigation efficiency may be due to inadequate water management at farm level and design problem of furrow irrigation. In Ethiopia, irrigation efficiencies are generally low, of the order of 25 to 50%, and problems with rising water tables and soil salinization are now emerging (EARO, 2002).

Furrow irrigation, recounted to be one of the least efficient methods compared with other irrigation methods and still one of the most widely used forms of surface irrigation. Irrespective of its application efficiency remaining relatively low not enough effort is being made to keep improving its management and efficiency. There is a need for basic technical parameters such as flow rate, furrow length and cut off time that easily applied to furrow irrigation system design in order to optimize for local condition (Di wu *et al.* , 2017).

Flow rate and furrow length are the main management and design parameters affecting irrigation efficiency (Eldeiry et al., 2005). However, proper selections of these parameters are not well practiced in the study area. The possibility of using optimum or longer furrow length in the farmers is very low. Therefore, appropriate selections of these parameters were significant element for improving the irrigation performances and crop yield under framers field. The main objectives of this study were to investigate the effect of decision variables on irrigation performances and yield of Onion crop around the study area.

## **Materials and Method**

### **The study area**

The study area was located Bako Woreda, West Shewa Zone ,Oromia Regional State with an altitude of 1590m above sea level and lies in 9°06' N and 37°09' E Latitude and longitude has mean monthly minimum and maximum temperature in the area are 13.7°C and 28.4°C respectively. Mean monthly annual dependable and effective dependable rainfall in the area were 808.5mm and 482mm, respectively. The potential evapotranspiration of the study area calculated using the CROPWAT Model is more than the effective dependable rainfall in most of the months and in this case, rainfall is insufficient to compensate for the water lost by evapotranspiration. This indicated that most of the crops planted in these months need supplemental irrigation.

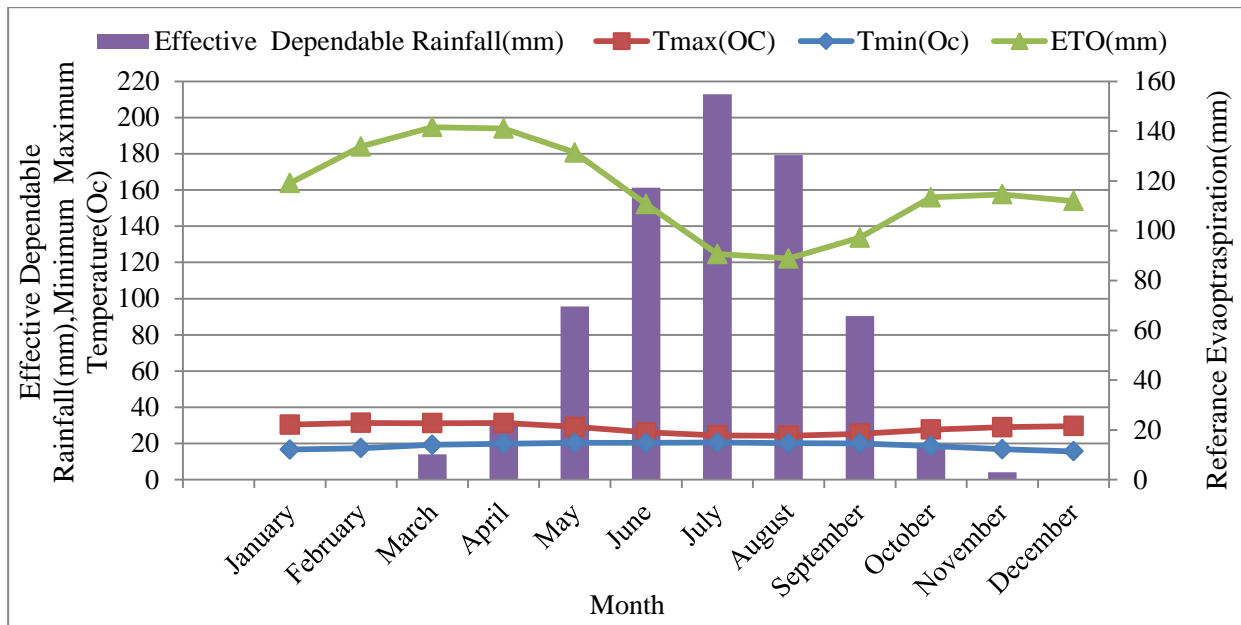

Figure 1. Monthly distribution of Reference evapotranspiration and effective dependable rain fall of study area

### Experimental Design and treatments

The treatments include two factors namely furrow length and flow rate. The levels of treatments include three level of both furrow length (F1, F2, and F3) and flow rate (Q1, Q2, Q3). The furrow length was 25m, 35m and 50m. The flow rate was made by rating of 50%, 75% and 100% of the maximum non erosive flow rate. The experimental field was arranged 3x3 factorial experiments in randomized complete blocks design with three replications. Each replication had nine treatments or plots and each plot had four furrows with 2.4m width. The treatments were assigned randomly into three blocks. The block and plot spacing were 1.5m and 0.5m respectively.

Table 1. Combinations of Experimental Treatment

Flow rate (l/s)	Furrow Length(m)		
	F1	F2	F3
Q1	F1Q1 (T1)	F2Q1 (T4)	F3Q1 (T7)
Q2	F1Q2 (T2)	F2Q2 (T5)	F3Q2 (T8)
Q3	F1Q3 (T3)	F2Q3 (T6)	F3Q3 (T9)

**Determination of Crop water Requirement and Irrigation Requirement:** Crop water requirement and irrigation scheduling of onion were prepared based on the meteorological data, the soil characteristics of the experimental site, and crop data. Onion crop coefficient (Kc) given by Allen *et al.*, (1998) as 0.7 for the initial stage,  $0.7 < Kc < 1.05$  for the crop development stage, 1.05 for the mid-season stage and  $0.95 < Kc < 1.05$  for the late-season stage.

The net irrigation requirement was calculated using crop water requirement and effective rainfall as described by Allen *et al.*, (1998). To determine the effective rainfall data probability analysis can be carried out so that a dependable rainfall (80% of probability exceedance) level of rainfall was selected. Dependable rainfall can be determined by using plotting rainfall probabilities or Weibull's formula (FAO, 1977).

$$P = \frac{100m}{N + 1} \quad (2)$$

Where; P=probability or plotting position (%),  
 m= rank number (after arranging rainfall data in descending order),  
 N= total data number

Finally, after determine the rainfall probability, effective dependable rain (FAO/AGLW) Formula was used to determine effective rain fall and gross irrigation requirement was calculated by considering 60% of field application efficiency.

**Soil Sample Collection:** For the Performance evaluation soil moisture content before and two days after irrigation at the initial and midseason growth stages of the onion crop at initial, mid (1/2L), and end of the furrow (L) along furrow length from each plot at three depths of onion 0-20cm, 20-40 cm, and 40-60cm was collected by using soil auger. To determine gravimetric moisture content, the gravimetric moisture determination method was used.

### Determination of Field Evaluation Parameters

**Furrow characteristics:** For measuring the cross-sectional area of furrows at the inlet, a furrow profilometer was done at Bako Agricultural Engineering Research center. A profilometer consists of round bars with 8mm in diameter and 500mm length and 1200mm wooden base. The cross-sectional area of the furrow at the inlet ( $A_o$ ) was determined from the manning equation and furrow geometry parameter coefficients (Walker and skerboe, 1987).

$$A_o = \left( \frac{nQ_o}{60\rho 1S_o^{0.5}} \right)^{1/\rho 2} \quad (4)$$



Figure 2. Furrow Profilometer and Furrow cross section Measurement

***Infiltration characteristics of Soil:*** The two-point methods of Elliot and Walker (1982) were used as a standard method for determining the infiltration characteristics of furrow irrigation from measurements of the irrigation advance phase. The basic infiltration rate was determined from the inflow outflow method (Elliot and Walker, 1982). In the two-point method proposed by Elliott and Walker (1982) the infiltration characteristics were described by the modified Kostiakov equation.

$$Z = K\tau^a + fo\tau \quad (7)$$

Where;  $Z$  = the cumulative infiltration per unit length of furrow ( $m^3/m/m$ )

$\tau$  = the intake opportunity time (min), and for any point

$fo$  = the basic intake rate ( $m^3/min/m$ )

$K$  and  $a$  = Infiltration parameters.

### Decision Variables

***Flow Rate ( $Q_o$ ):*** Flow rate must not exceed the maximum allowable non erosive amount. The maximum non-erosive flow rate was determined using the equation developed by (Hamad and Stringham, 1978).

$$Q_{max} = \frac{\alpha}{S^\beta} \quad (9)$$

Where:  $Q_{max}$  = Maximum flow rate (l/s)

$S$  = Furrow slope, %

$\alpha$  and  $\beta$  are coefficients of parameters based on soil group

The slope of the furrow was determined using line-level by measuring at 10m interval along furrow length. The experimental field had an average of furrow bed slope of 0.6% and clay loam in textural class which categorized as medium-heavy textured soil group (FAO, 1991). Based on these the Coefficient parameters for furrow maximum flow rate were  $\alpha=0.988$  and  $\beta=0.55$ . Therefore the maximum non erosive flow rate ( $Q_{max}$ ) obtained above formula was 1.31L/s and based on this values the three levels of flow rate, 50%, 75% and 100% of  $Q_{max}$  were 0.7 ,0.98 and 1.31L/s , respectively. These flow rates were diverted to the furrow by using calibrated parshall flume having appropriate opening diameter of three inch (3"). The calibration was done by volumetric measurement.

**Furrow length:** The three furrow length levels were 25, 35, and 50m. The selection of these furrow lengths was based on the existing furrow lengths being practiced by small scale irrigation farmers in the study area. As observed from field survey the majority of farmers' irrigated land is in the range of 25-50m long. So the lower and the upper values were taken and the third one was decided to be in between the two values. Therefore, 25, 35, and 50m were the furrow length levels used in this study.

#### Determination of Irrigation Performance parameters

Irrigation Performance parameters	Method of Determination
Application Efficiency	$E_a = Z_s/Z \times 100$ (Michael, 2008)
Storage Efficiency	$E_s = Z_s/Z_{req} \times 100$ (Michael, 2008)
Distribution uniformity	$D_u = Z_{min}/Z_{av} \times 100$ (Jurreins <i>et al.</i> , 2001)
Deep percolation ratio	$DPR = 100 - E_a - RR$ (FAO, 1989)
Christiansen's uniformity Coefficient	$UCC = \left[ 1 - \frac{\sum_{i=1}^N  Z_i - Z_{av} }{Z_{av} \cdot N} \right] \times 100$ ( Zerihun <i>et al.</i> , 1997)

Where,  $Z_s$  = depth of water retained in the root zone (mm) ,  $Z$  = depth of water applied to the furrow (mm),  $Z_{req}$ = Water required in the root zone before irrigation (mm),  $Z_{min}$  = the minimum infiltrated depth (mm) ,  $Z_{av}$  = the mean of depths infiltrated over the furrow length (mm) ,  $Z_i$  =Infiltrated Amount at point  $i$  (mm),  $N$ =Number of points used in the computation of UCC and  $Z_{av}$ = average of Infiltrated depth(mm).

**Onion Yield Collection:** The sample yield was collected from each treatment plot. Each treatment plot has four rows. The border rows were used as a buffer of middle rows and sample yield was collected from these two middle rows and the collected yield was weighted separately.

## Statistical Analysis

The collected data were analyzed using SAS 9.0 statistical software. For comparing means of the treatments that showed significant result, the least significant difference (LSD) test at 5% and 1% probability level was applied.

## Results and Discussion

### Crop water requirements and irrigation scheduling of onion

Crop water requirements and irrigation scheduling of onion were calculated by multiplying the reference evapotranspiration values with the onion crop coefficient (Allen et al, 1998) and computed as 438.39mm. The net crop water requirement was computed by deducting effective rainfall from ETc while Gross water requirement was computed by adopting a field application efficiency of 60% were 416.53 mm and 694.21mm respectively.

**Infiltration Characteristics of the soil:** A sample of inflow outflow hydrography for the treatment of F3Q3 (F3=50m and Q3=1.3l/s) was presented in Figure 4. The inflow-out flow method was used to determine the basic infiltration rate of the soil. The average basic infiltration rate was found to be 0.0000967m/min or 5.8mm/hr), which is in the range (0.000057 to 0.000107 m/min) value for clay loam (Walker, 1989).

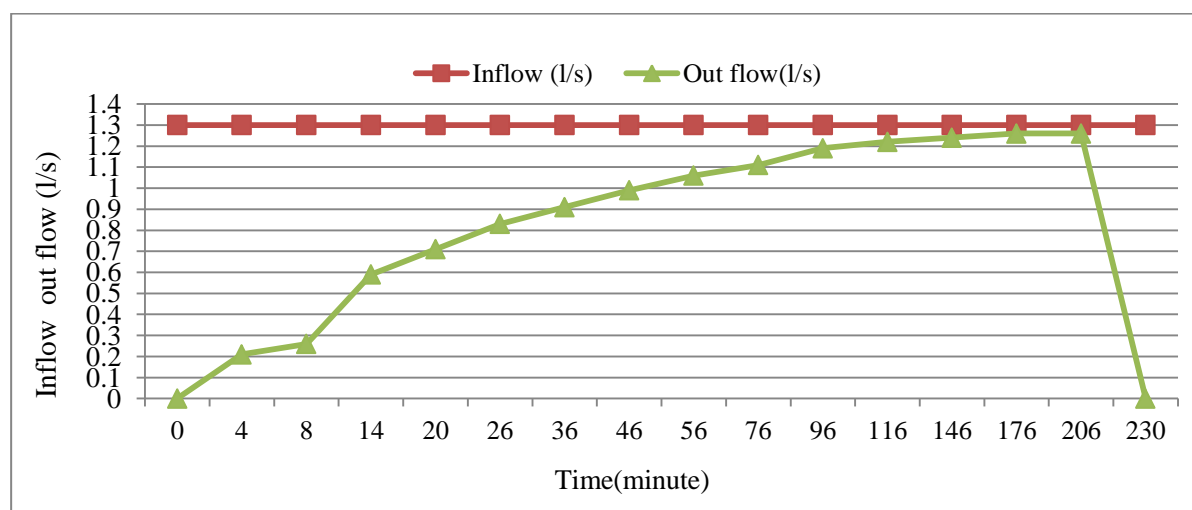

Figure 4. Inflow outflow hydrograph of F3Q3 for a furrow irrigation evaluation

The values of furrow geometric parameters and basic infiltration rate were used as input in the determination of infiltration parameters 'k and a' in Kostiaikov-Lewis equation. The infiltration parameters 'k and a' were found to be 3.64 mm/min<sup>a</sup> and 0.47 respectively by



using a volume balance method (Elliott and walker, 1982). Based on these data, the cumulative infiltration equation was derived as equation 8;

$$Z = 3.64t^{0.47} + 0.0967t \quad (8)$$

Where;  $z$  = depth of water infiltrated along furrow length (mm)  
 $t$  = intake opportunity time (min)

### Effect of Decision variables on Irrigation performance parameters and yield of onion

According to the analysis of variance (Table 2), the effect of furrow length and flow rate were highly significant at ( $p < 0.01$ ) on irrigation performance parameter and their interaction were significant at ( $p < 0.05$ ). Also the effect of flow rate were highly significant at ( $p < 0.01$ ) on yield of onion but the effect of furrow length and their interaction were non-significant on yield of onion.

Table 2. Analyses of variance (ANOVA) for Irrigation Performance parameter and yield onion

Source of variation	Irrigation Performance parameter and yield of onion					
	$E_a$ (%)	$E_s$ (%)	$D_U$ (%)	$U_{cc}$ (%)	$D_{PR}$ (%)	Y (ton/ha)
Furrow length (F)	21.46**	44.96**	9.93**	28.30**	21.46**	1.92 <sup>ns</sup>
Flow Rate (Q)	48.60**	89.08**	30.68**	43.10**	48.66**	11.36**
FXQ	3.15*	7.1**	5.40**	3.05*	3.01*	0.41 <sup>ns</sup>
CV	2.61	1.82	1.98	0.98	4.04	9.9
LSD(0.05)	0.53	0.52	0.59	0.89	0.53	1.49

Where: <sup>ns</sup> Non significant, \*Significant, \*\* highly significant,

### Application Efficiency ( $E_a$ )

The effect of furrow length was highly significant ( $p < 0.01$ ) on application efficiency (Table 2). Application efficiency has shown a decreasing trend as furrow length increased and the mean values of application efficiency were 63.28, 60.70 and 57.48% for F1, F2 and F3 furrow lengths (Table 2). This trend is in agreement with the finding of (Eldeiry et al., 2005). The effect of flow rate was highly significant ( $P < 0.01$ ) on application efficiency (Table 2). Application efficiency has shown an increasing trend as flow rate increased as shown in (Table 3). Mean values of application efficiency were 57.62, 59.85 and 64.00 % for Q1, Q2 and Q3 flow rates, respectively (Table 2). This is might be due to faster advance time at higher flow rate, leads to make minimum deep percolation loss below root zone of onion crop contribute to increase the application efficiency (Tefera et al ., 2016).

Table 3 .Effect of flow rate and furrow length on application efficiency

Furrow length(m)	Mean of Application Efficiency (%)			
	Flow rate(l/s)			
	Q1	Q2	Q3	Mean
<b>F1</b>	61.32 <sup>cd</sup>	62.87 <sup>bc</sup>	65.87 <sup>a</sup>	63.28 <sup>k</sup>
<b>F2</b>	57.94 <sup>e</sup>	59.34 <sup>de</sup>	64.64 <sup>b</sup>	60.70 <sup>l</sup>
<b>F3</b>	53.60 <sup>f</sup>	57.35 <sup>e</sup>	61.49 <sup>cd</sup>	57.48 <sup>m</sup>
<b>Mean</b>	57.62 <sup>l</sup>	59.85 <sup>f</sup>	64.00 <sup>s</sup>	60.49
<b>SEM(±)</b>	0.523	0.523	0.9	
<b>LSD(0.05)</b>	0.53	0.53	1.58	

\* Means with the same letter are not significantly different

### Storage Efficiency (Es)

The effect furrow of length and flow rate were highly significant ( $p < 0.01$ ) on Storage efficiency (Table 2). Storage efficiency has shown an increasing trend for increase in furrow length and mean values of  $E_s$  were 81.89, 88.02 and 89.13% for furrow length of F1, F2 and F3, respectively (Table 4). Similarly, (Tefera et al. 2016) has got an increasing trend of Storage efficiency with increases of furrow length. Storage efficiency has shown decreasing trend as flow rate increase and mean values of storage efficiency were 90.38, 87.68 and 80.97 % for Q1, Q2 and Q3 flow rates respectively (Table 4).

Table 4. Effect of flow rate and furrow length on Storage efficiency

Furrow length(m)	Mean of Storage efficiency (%)			
	Flow rate(l/s)			
	Q1	Q2	Q3	Mean
<b>F1</b>	85.59 <sup>d</sup>	82.03 <sup>f</sup>	78.05 <sup>g</sup>	81.89 <sup>j</sup>
<b>F2</b>	90.58 <sup>bc</sup>	89.03 <sup>c</sup>	84.47 <sup>d</sup>	88.02 <sup>k</sup>
<b>F3</b>	94.98 <sup>a</sup>	92.00 <sup>b</sup>	80.39 <sup>e</sup>	89.13 <sup>l</sup>
<b>Mean</b>	90.38 <sup>h</sup>	87.68 <sup>i</sup>	80.97 <sup>k</sup>	86.35
<b>SEM(±)</b>	0.523	0.523	0.908	
<b>LSD(0.05)</b>	0.52	0.52	3.5	

\* Means with the same letter are not significantly different

### Distribution uniformity (Du)

The effect of furrow length and flow rate were highly significant ( $p < 0.01$ ) on distribution uniformity (Table 2). The mean DU with respect to furrow length was found to 90.16, 88.33 and 86.30 % for Furrow length of F1, F2 and F3 respectively, and that of flow rate was 84.79, 88.57 and 91.37 % for Q1, Q2 and Q3, respectively (Table 5). The value of DU increases as the flow rate increased regardless of furrow lengths and decrease as the furrow length increase (Table 5). The reason might be small flow rate has slow advance time and high infiltration opportunity time which contribute to lowest distribution uniformity. This is agree with the reports of Di Wu, et al. (2017) stated as uniformity is an increasing function of flow rate and a decreasing function furrow length.

Table 5 . Effect of flow rate and furrow length on distribution uniformity

Furrow length(m)	Mean of Distribution uniformity (%)			
	Flow rate(l/s)			
	Q1	Q2	Q3	Mean
<b>F1</b>	87.89 <sup>bcd</sup>	90.41 <sup>abc</sup>	92.17 <sup>a</sup>	90.16 <sup>m</sup>
<b>F2</b>	86.06 <sup>e</sup>	87.83 <sup>de</sup>	91.11 <sup>abcd</sup>	88.33 <sup>k</sup>
<b>F3</b>	80.42 <sup>f</sup>	87.49 <sup>cde</sup>	90.85 <sup>ab</sup>	86.30 <sup>n</sup>
<b>Mean</b>	84.79 <sup>g</sup>	88.57 <sup>h</sup>	91.37 <sup>i</sup>	88.3
<b>SEM(±)</b>	0.58	0.58	1.007	
<b>LSD(0.05)</b>	0.59	0.59	1.79	

\* Means with the same letter are not significantly different

### Christiansen's uniformity coefficient

The analyses of variance showed that the effect of furrow length and flow rate on Christiansen's uniformity coefficient (UCC) was highly significant at  $p < 0.01$  (Table 2). The mean of UCC concerning furrow length was found to be 96.50, 94.53, and 92.58% for furrow length of 25, 35, and 50m and that of flow rate was 93.26, 92.33 and 94.26% for 0.7, 0.98 and 1.3 l/s flow rate respectively. As shown in Table 6, Furrow length and UCC have an inverse relationship as furrow length increases UCC showed a decreasing trend. This might be due to low variation of infiltration opportunity time along furrow length as flow rate increases which contribute to increases in the UCC with flow rate. The same trend was observed by Feyen and Dawit (1999), their study indicates the direct relation between flow rate and UCC and indirect relationship between furrow length and UCC.

Table 6. Effect of flow rate and furrow length on Christiansen's uniformity

Furrow length(m)	Mean of Christiansen's uniformity coefficient (%)			
	Flow rate(l/s)			
	Q1	Q2	Q3	Mean
<b>F1</b>	95.36 <sup>b</sup>	96.36 <sup>ab</sup>	97.97 <sup>a</sup>	96.50 <sup>k</sup>
<b>F2</b>	93.29 <sup>c</sup>	93.75 <sup>c</sup>	96.55 <sup>ab</sup>	94.53 <sup>l</sup>
<b>F3</b>	91.14 <sup>d</sup>	92.33 <sup>cd</sup>	94.26 <sup>e</sup>	92.58 <sup>m</sup>
<b>Mean</b>	93.26 <sup>q</sup>	94.15 <sup>r</sup>	96.26 <sup>s</sup>	95.00
<b>SEM</b>	0.29	0.29	0.51	
<b>LSD(0.05)</b>	0.30	0.30	0.89	

\* Means with the same letter are not significantly different

### Deep percolation Ratio (DPR)

The effect of furrow length and flow rate were highly significant at ( $p < 0.01$ ) on deep percolation ratio (Table 2). DPR increased as the furrow length increase and mean of DPR with respect to furrow length was found to be 36.72, 39.29 and 42.52 % for furrow length of

F1 , F2 and F3, Respectively(Table 5). DPR has shown decreasing trend as flow rate increases and mean value of DPR were 42.55, 40.08, and 36.07% for Q1, Q2 and Q3 flow rate(Table 5). This might be due to small flow rate has slow advance time on longer furrow length takes longer infiltrated opportunity time that could provide higher deep percolation ratio. Similarly Assefa S *et al.* (2017) got decreasing trend of deep percolation ratio as flow rate increases.

Table 7. Effects of flow rate and furrow length on deep percolation ratio

Furrow length(m)	Mean of Deep percolation ratio (%)			
	Flow rate(l/s)			
	Q1	Q2	Q3	Mean
<b>F1</b>	38.68 <sup>cd</sup>	37.13 <sup>de</sup>	34.35 <sup>f</sup>	36.72 <sup>j</sup>
<b>F2</b>	42.57 <sup>b</sup>	40.46 <sup>bc</sup>	35.36 <sup>ef</sup>	39.29 <sup>k</sup>
<b>F3</b>	46.40 <sup>a</sup>	42.65 <sup>b</sup>	38.51 <sup>cd</sup>	42.52 <sup>m</sup>
<b>Mean</b>	42.55 <sup>h</sup>	40.08 <sup>j</sup>	36.07 <sup>k</sup>	38.51
	F	Q	FXQ	
<b>SEM(±)</b>	0.53	0.53	0.92	
<b>LSD(0.05)</b>	0.53	0.53	1.58	

\* Means with the same letter are not significantly different

### Effect of flow Rate and furrow length on yield of onion

The effect of flow rate on yield was highly significant ( $p < 0.01$ ). But the effect of furrow length and its interaction with flow rate could not show any significant effect ( $P < 0.05$ ) on the onion yield (Table 2). The mean of onion yield obtained were 13.59, 14.95 and 19.61 ton/ha for Q1, Q2 and Q3 flow rate, respectively. The better yield was obtained at higher flow rate and increases as flow rate increases. This might be due to greater performance of application efficiency and distribution uniformity on higher flow rate. This report agreed with the trend of (Eduardo *et al.*, 2010). The effect of furrow length on yield of onion could not show any significant effect ( $P < 0.05$ ) on the onion yield. The Minimum and maximum onion yield obtained from the furrow length F1 (14.75 ton/ha) and F3 (15.96 ton/ha). In fact as irrigation is more uniform and meets crop water requirements, the crop production increases. This indicates an increase in crop yield is linked with water distribution uniformity rather than increases of furrow length. Similar trend were reported with Assefa S *et al.* (2017) their study show that there was no statistically significance difference yield of crop in terms of increases of furrow length except flow rate.

Table 8. Effect of flow rate and furrow length on yield of onion

Furrow length(m)	Yield ( ton/ha)	Flow rate(l/s)	Yield ( ton/ha)
F1	14.75 <sup>b</sup>	Q1	13.59 <sup>h</sup>
F2	14.77 <sup>b</sup>	Q2	14.95 <sup>h</sup>
F3	15.96 <sup>b</sup>	Q3	19.61 <sup>g</sup>
SEM	0.500	SEM	0.500
LSD(0.05)	1.49	LSD(0.05)	1.49

\* Means with the same letter are not significantly different

Note: F1=25m, F2 =35m , F3 =50m Q1=0.7l/s, Q2= 0.98l/s, Q3=1.3l/s

### Conclusions and Recommendations

Furrow irrigation is not only the primary consumer of water but it is also the most inefficient user. Considering this issues, a study was conducted to evaluate effect of decision variables (flow rate and furrow length) on irrigation Performance Parameters and yield of Onion Crop under small scale farmers' condition. The Results showed that the effect of furrow length and flow rates on application efficiency was highly significant ( $p < 0.01$ ).

The best result of 65.87 % was achieved for treatment combination of 1.3 l/s flow rate (Q3) and 25m furrow length (F1) and the least 53.60% for treatment combination of 0.7l/s (Q1) and 50m furrow length (F3). The effects of furrow length and flow rate on Storage efficiency was highly significant ( $p < 0.01$ ). The highest value of storage efficiency is formed 94.98% for treatment combination of 50m furrow length (F3) and 0.7l/s flow rate (Q1) and the lowest value of 78.05% for treatment combination of 25m furrow length (F1) and 1.3l/s flow rate (Q3). The effect of furrow length and flow rates on distribution uniformity was highly significant ( $p < 0.01$ ). The highest value of distribution uniformity of 92.17% for treatment combination of 25m furrow length (F1) and 1.3l/s flow rate (Q3) and the lowest value of 80.42% for treatment combination of 50m furrow length (F3) and 0.7l/s flow rate (Q3). Similarly, the effects of both furrow length and flow rates on deep percolation ratio was highly significant ( $p < 0.01$ ). The maximum deep percolation losses 46.40% was observed in treatment combination of 0.7l/s flow rate (Q1) and 50m furrow length(F3) while the least value of deep percolation was 34.35% for treatment combination of 25m furrow length (F1) with 1.3l/s flow rate (Q3). The effect of furrow length on yield of onion was not significant ( $p < 0.05$ ). However, the flow rate showed highly significant ( $p < 0.01$ ) effect on yield of onion. The best onion yield was obtained at Q3 which gave 19.61 ton/ha. Therefore, in a soil that

has clay loam texture, 0.6% furrow bed slope, and a furrow length of 50m, it is suitable to use 1.3 l/s of flow rate for better onion yield and irrigation performances.

## **Acknowledgements**

The authors would like to acknowledge Agricultural Engineering Research Directorate, Oromia Agricultural Research Institute providing the required budget to conduct the experiment. Besides, I would like to thank the Soil laboratory technicians of Oromia Water Works Design and Supervision Enterprise, Bako and Holota Agricultural Research Center for their effective and enthusiastic work in soil analysis.

## **References**

- Allen, R., Pereira, L.A., Raes, D. and Smith, M. 1998. Crop evapotranspiration. Irrigation and Drainage Paper No. 56. FAO. Rome.
- Assefa S, Kedir Y, Alamirew, T. 2017. Effect of slopes, furrow lengths and inflow rates on irrigation performances and yield of sugarcane plantation at Metehara, Ethiopia. Irrigation drainage systems eng, 6: 179.
- Elliott, R.L. and Walker, W.R. 1982. Field evaluation of furrow infiltration and advance function. Transaction of the ASAE, 25(2):396-400.
- Di Wu, Jingyuan Xue, Xiaodong Bo, Weichao Meng, Youjie Wu and Taisheng Du. 2017. Simulation of Irrigation Uniformity and Optimization of Irrigation Technical Parameters Based On the SIRMOD Model under Alternate Furrow Irrigation. Irrig. and Drain. 66: 478–491.
- EARO (Ethiopian Agricultural Research Organization).2002. Concept Paper on Agricultural Water Management. Addis Ababa, Ethiopia.15pp.
- Eldeiry, A., Garcia, L.A, El-Zaher, A.S, and Kiwan, M.E. 2005. Furrow irrigation system design for clay soils in arid regions. Appl. Eng. Agric. 21:411-420.
- Eduardo A. Holzapfel, Carlos L, Migue A. Mariño, Jerónimo P, José L. Arumí, and Max B.2010 .Furrow Irrigation Management and Design Criteria Using Efficiency Parameters and Simulation Models. Chilean Journal of Agricultural Research 70(2):287-296.
- EARO (Ethiopian Agricultural Research Organization).2002. Concept Paper on Agricultural Water Management. Addis Ababa, Ethiopia.15pp.
- Food and Agriculture Organization .1989. Guidelines for Designing and Evaluating Surface Irrigation Systems.
- FAO(Food and Agricultural Organization).1991. A Manual for the Design and Construction of Water Harvesting Schemes for Plant Production. Rome
- FAO(Food and Agriculture Organization). 1977. Crop water requirements. FAO Irrigation and drainage paper 24, Rome.
- Hamad, N. S., and Stringham, G. E. 1978. Maximum non-erosive furrow irrigation stream size. Journal of Irrigation and Drainage Division. American Society of Agricultural Engineers, 104: 275-279.
- Michael, A.M. 2008. Irrigation: Theory and Practice. Second edition. Vikas Publishing House Pvt. Ltd, Delhi. P. 554-577.

- Jurreins, M., Zerihum D., Boonasta J., and Feyen J. 2001. SURDEV: Surface Irrigation Software. *ILRI Publication 59*.
- Tefera T, Kannan K, and Hordofa T. 2016. Effect of Furrow Length and Flow Rate on Irrigation Performances and Yield of Maize. *International Journal of Engineering Research & Technology*. Vol. 5 Issue 04.
- Zerihun, D., Wang Z., Rimal S. and Feyen J. 1997. Analysis of surface irrigation Performance terms and indices. *Agricultural Water Management* 34: 25-46.
- Walker, W.R. and Skogerboe G.V. 1987. *Surface Irrigation: Theory and Practice*. Prentice Hall, New Jersey; 386 P.
- Walker, W. R. 1989. *Guidelines for Designing and Evaluating Surface Irrigation System: Irrigation and drainage paper No. 45*. FAO, Rome.

# Effects of Furrow Irrigation Methods and Mulching on Growth, Yield and Water Use Efficiency of Tomato at Bako Tibe, Western Shewa

Eshetu Mekonnen\*, Habtamu Bedane, Gudeta Genemo

Oromia Agricultural Research Institute, Bako Agricultural Engineering Research Center

\*Corresponding author e-mail: [eshetumoke2@gmail.com](mailto:eshetumoke2@gmail.com)

## Abstract

*Sustainable irrigation method is now essential for adaptation and adoption in the areas where water resources are limited. Therefore, a field experiment was conducted to test the combined effect of alternate wetting and drying furrow irrigation, conventional irrigation method and mulches on crop growth, yield and water use efficiency of tomato. The treatments of the experimental area comprised of two irrigation method (conventional and alternate furrow irrigation method) and three mulches (maize, soybean and wheat straw). The yield and yield-component characters in the mulched treatments for two of furrow irrigation method were significantly higher compared to those in the un mulched (bare soil) treatments. The yields of tomato were higher in conventional furrow irrigation method than alternate furrow irrigation method. The highest yield 82267 kg/ha for maize straw, 88004.5 kg/ha for soybean straw and 87074 kg/ha for wheat straw was obtained at conventional furrow irrigation method. Soybean and wheat straw mulched treatment produced higher yield than the maize straw-mulched treatment. The highest water use efficiency of 16.221 kg/ha/m<sup>3</sup> and 15.978 kg/ha/m<sup>3</sup> was obtained with alternate furrow irrigation method under soybean and wheat straw mulch respectively. The study thus reveals that alternate furrow irrigation method with mulch has an explicit role in increasing the water use efficiency of tomato.*

**Keyword:** furrow irrigation, mulch, tomato, water use efficiency

## Introduction

Tomato is one of the most important and widely grown vegetable in Ethiopia. Fresh, processing and cherry types are produced in the country. Small-scale farmer produces the bulk of fresh market tomatoes. Processing types are mainly produced in large-scale horticultural farms. It is an important cash-generating crop to small scale farmers and provides employment in the production and processing industries. It is also important source of vitamin A and C as well as minerals. Farmers are interested in tomato production more than any other vegetables for its multiple harvests potential of year round production, which results in high profit per unit area.



The Production of the tomato crop in most of western Shewa had been limited by several factors among which are irrigation water management and environmental factors that include temperature, humidity and rainfall. Sometimes, many of the farmers can't able to provide irrigation due to unavailability of irrigation facilities and scarcity of irrigation water. Under this situation mulching and alternate furrow irrigation could be a good substitute means of irrigation to save soil moisture.

Proper irrigation management increases the water use efficiency; consequently, the production per unit of water will be increased. The degradable mulch has been designed to be incorporated into the soil profile, eliminating the need for polyethylene mulch removal at the end of the growing season (Subrahmaniyan & Zhou, 2008). It is one of the agricultural practices that take into account the preservation of the environment compared with polyethylene mulch, which is one of the recognized priorities in the world. Investigations of degradable mulch have proven their favorable impact on crop yields and the ecosystem (Siwek et al., 2013). Benefits of mulch include the enhancement of soil structure, soil fertility, 2000) and preservation of environmental quality (Yadev et al., 2000).

The development towards optimum utilization of irrigation is to irrigate alternate furrows (Zhang et al., 2000). It is presumed that irrigating alternative furrows can help to save irrigation water both by minimizing evaporative loss from plant leaf due to reduced stomata opening with absence of visible leaf water deficit and by reducing deep percolation losses at the same time.

## **Materials and methods**

### **Experimental Site Description**

The study was conducted at Oda Haro, BakoTibe, West Shewa which was located at altitude of 1690 meter above sea level, 9° 08' N latitude and 37 °03' E longitude, respectively. The mean annual rainfall is about 1237mm, which was occurred in July.

### **Experimental design and treatments**

The treatments considered for this experiment were two levels of furrow irrigation methods and three levels of mulches. Two levels of furrow irrigation methods (conventional furrow and alternate furrow irrigating methods) and three levels of mulches (maize mulch, soya bean

and wheat mulches). The experimental field consisted of 24 plots with a dimension of 5m x 6m.

The experimental field was arranged as factorial experiments in RCBD with three replications. These treatments are;

- T1=Conventional furrow irrigation with maize mulch
- T2=Conventional furrow irrigation with soybean mulch
- T3=Conventional furrow irrigation with wheat mulch
- T4=Conventional furrow irrigation without mulch
- T5=Alternate furrow irrigation with maize mulch
- T6=Alternate furrow irrigation with soybean mulch
- T7=Alternate furrow irrigation with wheat mulch
- T8=Alternate furrow irrigation without mulch



Figure 1: Tomato plant at experimental site

### **Estimation of crop water requirements**

The actual crop evapotranspiration was ( $ET_a$ ) computed by multiplying the reference evapotranspiration ( $ET_o$ ) with crop coefficient ( $K_c$ ) for different growth stages of the crop.  $ET_o$  was calculated on a daily basis from daily meteorological data using the CROPWAT 8.0 model. The model uses FAO Penman-Monteith equation, which was accepted as standard method to calculate reference evapotranspiration (Allen et al., 1998).

### **Irrigation water use efficiency**

Irrigation water use efficiency (IWUE) was calculated as the ratio between the yields harvested (kg) and the total volume of water applied ( $m^3$ )

### **Water application efficiency (Ea)**

It is the ratio of the volume of water stored in the subject region to the volume of water diverted into the subject region.

$$E_a = W_s/W_f \times 100$$

Where,  $W_f$  = water stored in crop root zone, cm

$W_f$  = water delivered at the head end of the furrows, cm

### **Data management and analysis**

All relevant data were recorded, stored and managed in Microsoft excel .The collected data were arranged and organized for the suitability of statistical analysis and finally analysis of variance (ANOVA) was performed using R software. Least significant difference (LSD) at 5% level significance was used to make mean separation among treatments.

## **Results and Discussion**

### **Soil physical properties**

As depicted from laboratory analysis, particle size distribution indicated that the soil is sandy clay loam in textural class throughout the soil depth with an average particle size distribution of 47%, 32%, and 21% of clay, silt and sand respectively. The average of moisture content at field capacity and permanent wilting point were 36.75 and 23.75 %, respectively. The average of bulk density  $1.29 \text{ g/cm}^3$  was obtained by considering 0 - 40 cm soil, and the average of total available water under this depth was found to be 169.01 mm/m.

Table 1 .Physical properties of soil at experimental field

Depth (cm)	Clay (%)	Silt (%)	Sand (%)	Textural class	BD ( $\text{g/cm}^3$ )	FC (%)	PWP (%)	TAW (mm/m)
0-20	44	41	15	Clay	1.28	34.9	23.1	151.33
20-40	50	23	27	SCL	1.31	38.6	24.4	186.69
Average	47	32	21	Clay loam	1.29	36.75	23.75	169.01

## Crop water requirements and irrigation scheduling of tomato

Based on the output of the CROPWAT 8 model, the seasonal irrigation requirement in the study area for tomato was found to be 578.2 mm (Table 2). The highest evapotranspiration values for the irrigated treatments occurred in the mid stage.

Table 2: Estimated water requirement for different growth stages of tomato

Month	day	Stage	Kc	Etc. (mm/day)	ETc (mm/dec)	Eff rain mm/dec)	Irr. Req (mm/dec)
December	10	Initial	0.6	2.34	2.34	-	2.34
December	20	Initial	0.6	2.32	23.2	-	23.2
December	31	Initial	0.6	2.35	25.9	-	25.9
January	09	Development	0.6	2.41	24.1	-	24.1
January	19	Development	0.70	2.85	28.5	-	28.5
January	30	Development	0.85	3.55	39	-	39
February	09	Development	0.99	4.29	42.9	-	42.9
February	19	Mid	1.12	5.00	50	-	50
February	27	Mid	1.15	5.20	41.6	-	41.6
March	08	Mid	1.15	5.28	52.8	13.2	39.6
43March	18	Mid	1.15	5.36	53.6	18	35.6
March	29	Mid	1.15	5.20	57.2	19.1	38.1
April	08	Late	1.12	4.90	49.0	18.9	30.1
April	18	Late	1.0	4.24	42.4	20	22.4
April	28	Late	0.88	3.62	36.2	25.3	10.9
May	1	Late	0.80	3.19	9.6	9.4	0
Total					578.2	123.9	417.9

## Effect of mulch and irrigation method on yield and yield component of tomato

**Number of fruit per plant:** ANOVA indicated that the effect of irrigation method and mulch system has highly significant ( $p < 0.01$ ) on number of fruit per plant. The highest number of fruit per plant 55.667 was observed under conventional Furrow and the lowest number of fruit per plant 39.833 was observed under alternative Furrow irrigation (Table 3). The highest number of fruit per plant 52.433 was observed under soya bean mulch and The lowest number of fruit per plant 51.167 and 39.7 was observed under wheat mulch and un mulch or control (Table3). This agrees with the report of (Akhtar et al., 2001) who reported that natural mulches such as leaf, rice straw, dead leaves and compost increase fruit per plant, length and yield.

Interaction effect of effect of irrigation method and mulch system significant ( $p < 0.01$ ) on number of fruit per plant. The highest number of fruit per plant 59.00 was observed under

interaction of Conventional furrow with soybean mulch and lowest number of fruit per plant 44.06 was observed under alternative furrow with wheat mulch (Table 3).

**Plant height:** ANOVA indicated that the effect of irrigation method and mulch system has highly significant ( $p < 0.01$ ) on plant height. The highest number of plant height 88.433 cm was observed under conventional and lowest number of plant height 72.85 cm was observed under alternative Furrow (Table 3). The highest plant height 84.87cm was observed under soya bean mulch and lowest number of plant height 83.03 cm and 72.700 cm was observed under wheat mulch and un mulch or control. These results are in line with (Yaseen et al., 2014) who reported that, leaf area and plant height were significantly affected by the mulching treatments.

Interaction effect of effect of irrigation method and mulch system significant ( $p < 0.05$ ) on number of plant height. The highest number of plant height 93 cm was observed under interaction of Conventional furrow with soybean mulch and lowest number of plant height 76.13 cm and 62.8 cm was observed under interaction of alternative furrow with wheat mulch and Alternate furrow un mulch (Table 3).

**Number of branch per plant:** ANOVA indicated that the effect of irrigation method and mulch system has highly significant on number of branch per plant. But interaction was not significantly affected ( $P < 0.05$ ). The highest branch per plant 9.700 was observed under conventional Furrow and lowest branch per plant 7.33 was observed under alternative furrow. The highest number of branch per plant 9.10 and 9.03 was observed under wheat and soybean mulch (Table 3).

**Yield of tomato:** ANOVA indicated that the effect of irrigation method and mulch system has highly significant on yield of tomato. But the interaction was not significantly affected ( $P < 0.05$ ). The highest yield 81200 kg/ha were observed under conventional furrow and lowest yield 4695 kg/ha were observed under alternative furrow (Table 3). The highest yield 70430 kg/ha was observed under soya bean mulch and lowest yield 64721 kg/ha and 5168 kg/ha was observed under wheat mulch and un mulch or control (Table 3).

Table 3: Effect of mulch and irrigation method on yield and yield component of tomato

Factor levels/ interactions	Number of fruit per plant	Plant height (cm)	No. of branch/plant	Yield( kg/ha)
<b>Furrow method</b>				
<b>Conventional</b>	55.667 A	88.433A	9.7000A	81200A
<b>Alternate</b>	39.833B	72.850B	7.3333B	46952.5B
<b>Significance</b>	***	***	***	***
<b>CV</b>	1.763934	1.869015	5.40202	3.3275
<b>LSD (5%)</b>	4.218912	1.319717	0.4028	1866.93
<b>Mulch</b>				
<b>Maize mulch</b>	47.700 B	81.967 B	8.600 A	64721C
<b>Soybean mulch</b>	52.433 A	84.867A	9.033 A	70430A
<b>Wheat mulch</b>	51.167 A	83.03AB	9.100 A	69471B
<b>Un mulch</b>	39.700C	72.700 C	7.3333B	51683D
<b>Significance</b>	***	***	***	***
<b>CV</b>	4.2189	1.86902	5.402	3.327
<b>LSD (5%)</b>	2.4945	1.86636	0.5697	2640.23
<b>Interaction</b>				
<b>Furrow X mulch</b>				
<b>Conventional maize mulch</b>	55.133B	88.200B	9.600	82267
<b>Conventional soybean mulch</b>	59.000A	93.000 A	10.40	88004.5
<b>Conventional wheat mulch</b>	58.267AB	89.933 B	9.933	87074
<b>Conventional un mulch</b>	50.267C	82.600 C	8.867	67454
<b>Alternate maize mulch</b>	40.267 E	75.733 D	7.600	47175
<b>Alternate soybean mulch</b>	45.867D	76.733 D	7.667	52855.9
<b>Alternate wheat mulch</b>	44.067D	76.133 D	8.267	51868
<b>Alternate un mulch</b>	29.133 F	62.800 E	5.800	35911
<b>Significance</b>	*	***	NS	NS
<b>CV</b>	4.21891	1.86902		
<b>LSD (5%)</b>	3.52787	2.63943	-	

\*= significant, \*\*\*= highly significant and NS= non-significant

## **Effect of Mulch and Irrigation Method on Water Use Efficiency of Tomato**

### **Crop water use efficiency**

The analysis of variance for the average data revealed that the effect of irrigation method was highly significant ( $p < 0.01$ ) on tomato crop water use efficiency. Alternate furrow irrigation method ( $16.24 \text{ kg/m}^3$ ) was highly significant in crop water use efficiency than conventional furrow method ( $14.04 \text{ kg/m}^3$ ) (Table 4). Moreover, tomato crop water use efficiency was highly significant influenced due to different mulch materials (Table 4). This is due to the presence of mulch material reduce evaporation from the wet soil surface. In contrast to this, the interaction effect of the two factors, furrow irrigation methods and mulch types, had no significant effect on crop water use efficiency of tomato.

### **Irrigation water use efficiency**

The analysis of variance showed that, irrigation water use efficiency was significantly affected by irrigation method. The highest water use efficiency of  $17.7 \text{ kg/m}^3$  and  $17.3 \text{ kg/m}^3$  was obtained with alternate furrow irrigation method under soybean and wheat straw mulch respectively (Table 4). Compared to conventional furrow irrigation, alternate furrow irrigation saved 20–33% irrigation water shortened the time required for irrigation and substantially improved water use efficiency. No significant differences were observed for the interaction effect among mulch treatments. These results are in line with (Yaseen et al., 2014).

Irrigation water use efficiency of mulched treatments were significantly higher than bare soil treatments (Table 4). These result are in line with that of (Hou et al., 2010; Debashis et al., 2008) who reported that irrigation water use efficiency under different mulches treatments are effective in reducing soil evaporation, and increasing plant water use efficiency.

### **Application Efficiency**

From the result we observed that, Alternate furrow irrigation method (73.623%) were highly significant in water application efficiency than conventional furrow irrigation method (69.297%). The highest (78.257%) water application efficiency was resulted from alternate furrow irrigation method with wheat mulch while the lowest (62.647) was recorded under treatment conventional furrow method with bare soil (Table 4). In coincidence with this result, (Manisha et al., 2016) reported that furrow irrigation application efficiencies range was found to be 65.26% - 81.96%. Research shows that use of surface mulch can result in storing more irrigation water in soil by reducing runoff, increasing infiltration and decreasing

evaporation (Ji and Unger, 2001).The interaction effect between different mulches and furrow has not significantly different from each other in water application efficiency.

Table 4: Effect of mulch and irrigation method on water use efficiency of tomato

Factor levels/ interactions	CWUE(kg/ha/mm)	IWUE(kg/m3)	Application Efficiency (%)
Furrow method			
Conventional	14.044 B	13.601B	69.297B
Alternate	16.241A	15.724A	73.623A
Significance	***	***	***
CV	2.145	2.145	1.221634
LSD (5%)	0.3778	0.3659	0.764385
Mulch			
Maize mulch	15.273B	14.789C	72.198C
Soybean mulch	16.752A	16.221A	73.472B
Wheat mulch	16.500A	15.978A	75.945A
Un mulch	12.044C	11.663D	64.225 D
Significance	***	***	***
CV	2.145	2.145	1.221634
LSD (5%)	0.5343	0.5174	1.081004
Interaction			
Furrow X mulch			
Conventional maize mulch	14.228	13.780D	69.577
Conventional soybean mulch	15.220	14.741C	71.330
Conventional wheat mulch	15.059	14.585C	73.633
Conventional un mulch	11.666	11.299E	62.647
Alternate maize mulch	16.318	15.799A	74.820
Alternate soybean mulch	18.283	17.701	75.613
Alternate wheat mulch	17.941	17.370	78.257
Alternate un mulch	12.422	12.026E	65.803
Significance	NS	***	NS
CV		2.145	
LSD (5%)	-	0.7318	-

\*= significant, \*\*\*= highly significant and NS= non-significant



## Conclusions and Recommendation

Increasing water use efficiency by planting with mulch could potentially allow year-round planting by farmers. Planting tomatoes with alternate furrow irrigation method by incorporating mulching material was found to increase water use efficiency significantly during the dry season. Our study confirms that, the most successful tomato production occurs on soybean and wheat mulch. Therefore, based on our findings, we recommend that soybean and wheat mulch are the best for tomato production in our experimental area. Moreover, our study demonstrates that good results can be obtained with maize mulches. The poorest results were obtained for alternate furrow irrigation method those cultivated on bare soil with no mulch. Finally we recommend at scarcity of water; farmers can use alternate furrow irrigation method with wheat or soybean mulch to achieve high water use efficiency. However, if there is excess amount of water farmers can use conventional furrow irrigation method with wheat or soybean mulch.

## References

- Allen, R., Pereira, L.A., Raes, D. and Smith, M. 1998. Crop evapotranspiration. Irrigation and Drainage Paper No. 56. FAO. Rome
- Akhtar S, Wahid A, Akram M, Rausl E (2001) Some growth, photosynthetic and anatomical attributes of sugarcane genotypes under NaCl salinity. *International Journal of Agriculture and Biology* 3(4): 439-443.
- Debashis, C., Shantha, N., Pramila, A., Gupta, V.K., Tomar, R.K., Garg, R.N., Sahoo, R.N., Sarkar, A., Chopra, U.K., Sundara, K.S., Kalra, N., 2008. Effect of mulching on soil and plant water status, and the growth and yield of wheat (*Triticum aestivum* L.) in a semi-arid environment. *Agric. Water Manag.* 95 (1323), 1334
- Hou, X.Y., Wang, F.X., Han, J.J., Kang, S.Z., Feng, S.Y., 2010. Duration of plastic mulch for potato growth under drip irrigation in Northwest China. *Agric. For. Meteor.* 150, 115–121.
- Ji, S.N and Unger, P.W. 2001. Soil water accumulation under different precipitation, potential evaporation, and straw mulch conditions. *Soil Science Society of American Journal*, 65 (2): 442-448
- Kang S., Lianga Z., Panb Y., Shic P., Zhang J. 2000. Alternate furrow irrigation for maize production in an arid area. *Agricultural Water Management*, 45:267-274
- Manisha. L et al. (2016). Performance evaluation of furrow irrigation system for brinjal with different mulches. Department of soil and water engineering svcaet & research station faculty of agricultural engineering indira gandhi krishi vishwavidyalaya raipur (chhattisgarh) 2016.
- Siwek, P., Libik, A., Kalisz, A. & Zawiska, I. (2013). The effect of biodegradable nonwoven direct covers on yield and quality of winter leek. *Folia Horticulture*, 25, 61-65.
- Subrahmanian, K. & Zhou, W. (2008). Soil temperature associated with degradable, non-degradable plastic and organic mulches and their effect on biomass production, enzyme activities and seed yield of winter rapeseed. *Sustainable Agriculture*, 32, 611-627.

- Yadav, R.L., Dwivedi, B.S. and Pandey, P.S. 2000. Rice–wheat cropping system: Assessment of sustainability by green manuring & chemical fertilizer inputs. *Field Crops Resources*, 65:15–30.
- Yaseen, R., Shafi, J., Ahmad, W., Rana, M.S., Salim, M., Qaisrani, S.A., 2014. Effect of deficit irrigation and mulch on soil physical. *Science* 19, 37–45
- Zhang, J., S. Kang, Z. Liang., Y. Z. Pan, P. Shi, Y. H. Pan, Z. S. Liang, X. T. Hu. 2000. Soil water distribution, uniformity and water use efficiency under alternate furrow irrigation in arid areas. *Irrigation Science* 19: 181-190.

# Effect of deficit irrigation on yield and water use efficiency of maize at Indris irrigation scheme of Eastern Wollega, Ethiopia

Gudeta Genemo\*, Eshetu Mekonnen, Habtamu Bedane

Oromia Agricultural Research Institute, Bako Agricultural Engineering Research Center

\*Corresponding author e-mail: [Agenemo@gmail.com](mailto:Agenemo@gmail.com)

## Abstract

Scarcity of water is the most severe constraint for development of agriculture in arid and semi-arid areas. The purpose of this study was to investigate deficit irrigation effect on yield and water productivity of maize under conventional furrow irrigation system and to identify the level of deficit irrigation which allows achieving optimum yield and water productivity of maize. The field experiment was laid out Randomized completely block design arrangement of four deficit irrigation levels with three replication. Results indicated that, plant height, cob length, cob diameter grain yield and water use efficiency (WUE) were significantly ( $p < 0.01$ ) affected by deficit irrigation levels. The highest and the lowest grain yield were recorded from 100%ETC and 50%ETC, respectively. The highest grain yield 5346.9 kg/ha was observed from the control treatment (100% ETC) and the minimum yield 3061.5kg/ha was observed from (50% ETC). The highest crop water use efficiency (1.43kg/ha/mm) was obtained under (50% ETC) and the lowest mean value of crop water use efficiency (1.29kg/ha/mm) was obtained under full irrigation water application (100% ETC). The highest irrigation water use efficiency (1.08kg/m<sup>3</sup>) was obtained under (50% ETC) and lowest irrigation water use efficiency (0.94kg/m<sup>3</sup>) was obtained under (50% ETC). The economic analysis revealed that application of 75% ETC under conventional furrow irrigation system was economically feasible for small scale farmers with low cost of production to get higher net benefit. Therefore, for this particular maize variety (shoney) it could be concluded that applying 75% ETC deficit irrigation level through whole growing stage under conventional furrow irrigation system saved water 128.9mm (1288.8m<sup>3</sup>/ha) or 0.33ha additional area can be irrigated by the amount of water saved compared to full irrigation level, which could be used for downstream water user in the irrigation scheme by pumping the water for the same crop under similar climatic condition around the study area.

**Keywords:** deficit irrigation, water use efficiency, maize

## Introduction

In Ethiopia, Irrigated Agriculture is becoming main concern and strongly recognized to ensure the food security which is taken as a means to increase food production and self-sufficiency of the rapidly increasing population of the country. Growing population pressure, rapidly declining natural resource base and rainfall variability (spatial and temporal) have secured irrigated agriculture as a prominent position on the country's development agenda

(Sisay *et al.*, 2011). Increasing competition of water due to the development of different water use sectors had imposed the improvement of water use efficiencies to ensure sustained production and conservation of this limited resource (Mekonen, 2011).

However, some small scale irrigation schemes developed are neither covering the designed command area nor producing optimum yield mainly because of structural problems and poor irrigation water management (Seleshi and Mekonnen, 2011). This is true for Indris small scale irrigation scheme and farmers found at downstream of the irrigation scheme are increasingly vulnerable to water supply shocks. This water shortage has motivated some researchers and farmers to find ways to produce a crop with less irrigation water and changing from fully-irrigated to deficit irrigated cropping system which maximizing water use efficiency for higher yields per unit of irrigation water applied.

Therefore, practically investigating the effect of deficit irrigation on yield and water productivity of irrigated maize was found to be important to utilize the limited water resource of the area without severely affecting the crop yield. The objective of this study is to investigate the effect of deficit irrigation on yield and water use efficiency of maize under conventional furrow irrigation system and to identify the level of deficit irrigation which allows achieving optimum Onion yield and water productivity of maize.

## **Materials and Methods**

The field experiment was conducted at Eastern wollega zone, Sibuleworeda char kebele, which was located about 270 km west of the capital city of Ethiopia, Addis Ababa. The experiment was located an altitude of 1826 meters above sea level and lies in 9°02'38.9" N and 36°52'31.3" E Latitude and longitude respectively. Average maximum and minimum temperature of the area was about 23.2 and 13.9°C respectively.

### **Experimental Design and treatments**

The experiment was designed with four deficit irrigation level under conventional furrow irrigation methods. The experiment was laid out in a Randomized Complete Block Design (RCBD) with three replications of four level treatments. Maximum deficit of 50% of ET<sub>c</sub>, is selected because 55% of Maximum Allowable Deficit (MAD) is recommended for grain maize (Allen *et al.*, 1998). Experimental treatments were assigned to the plot by randomizing

them within each block using random number .The experiment plot has a net size of 6m X 8m and has spacing of 75cm X 25cm between rows and plants respectively. Maize crop of Shone variety was planted with spacing of 75cm x 25cm between rows and plants respectively.

Experimental treatments were;

T1 = Irrigation water application of 100% ETc

T2 = Irrigation water application of 85% ETc

T3 = Irrigation water application of 75% ETc

T4 = Irrigation water application of 50% ETc

### **Soil Sampling and Analysis**

Soil samples were taken at depths (0-20cm, 20-40cm, and 40-60 cm) from the experimental site. Disturbed composite soil samples were taken using auger for the analysis of soil texture, PH, and EC. Bulk density, PH, and EC were done at Bako Agricultural Research center. For Bulk density determination undisturbed soil samples collected by using core sampler. The soil samples were weighed and placed in an oven at 105 °c for 24 hours the oven dried soil was weighted and then the bulk density was determined. Moisture contents at field capacity and permanent wilting point were carried out at Oromia water work design and supervision Soil Laboratory Pressure Plate apparatus was used to determine the moisture content at FC and PWP by applying pressures at 0.33bar (for FC) and 15bar (for PWP). Hence, the total available water (TAW), stored in a unit volume of soil, is approximated by taking the difference between the water content at field capacity (FC) and at permanent wilting point (PWP). Therefore, the total available water was calculated as follow;

$$TAW = \frac{(FC - PWP) * BD * DZ}{100}$$

Where; TAW = total available water in mm/m,

FC = field capacity and PWP is permanent wetting point in percent (%) on weight basis,

BD = bulk density of the soil in gm/cm<sup>3</sup> and

Dz = maximum effective root zone depth of maize in mm

### **Crop water Requirement and Irrigation scheduling**

Crop water requirement and irrigation scheduling of maize were prepared based on long term meteorological data (1998 - 2015) which collected from national metrology agency, the soil characteristics of the experimental site, and crop data. Maize crop coefficient (Kc) from given by Allen *et al.*, (1998) and Crop water requirement was determined by multiplying the ETo with crop coefficient (Kc). The net irrigation requirement was calculated using crop water

requirement and effective rainfall as described by Allen *et al.*, (1998). To determine the effective rainfall, dependable rain (FAO/AGLW Formula) was used (FAO, 2009) and gross irrigation requirement was calculated by considering 60% of application efficiency. The amount of water applied to the experimental field was measured by 3-inch Parshall flume. The time required to deliver the desired depth of water into each plot was calculated using the equation (Kandiah, 1981).

$$t = \frac{dg \times A}{6 \times Q}$$

Where; dg = gross depth of water applied (cm), t = application time (min)  
A = Area of experimental plot (m<sup>2</sup>) and Q = discharge (l/s)

The irrigation depth was converted to volume of water by multiplying it with area of the plot

$$V = A \times dg$$

Where: V = Volume of water in (m<sup>3</sup>), A = Area of plot (m<sup>2</sup>)  
dg = Gross irrigation water applied (m)

### **Data Collection**

Representative five maize plant samples were cut at ground level after plant height recorded and collected per plot from the central ridge (row) of each treatment. Data on maize yield and yield parameter like plant height, cob length, and cob diameter was collected.

### **Crop water production function**

Crop water production function was developed by fitting crop yield and seasonal water requirement (ETc) into various regression equations and the one with highest determination coefficient was adopted.

$$Y = a + b (ETc) + c (ETc)^2 + d (ETc)^3$$

Where: Y = grain yield (kg/ha)  
ETC = Seasonal actual evapotranspiration in mm  
a = Y-axis intercept  
b, c and d = Regression coefficients indicating the magnitude of yield variation (kg/ha) per unit increase in ETC

### **Crop water and irrigation water use efficiency**

Crop water and irrigation water use efficiency is the ratio of crop yield to the amount of water consumptively used by the crop and yield per unit of total irrigation water applied, respectively (Igbadun *et al.*, 2007).

## Yield Response Factor

The yield response factor ( $K_y$ ) defined as the decrease in yield with respect to the deficit in water consumptive use (ET) and was calculated according to the procedure mentioned by (Doorenbos and Kassam, 1979).

$$1 - \frac{Y_a}{Y_m} = ky \left( 1 - \frac{ET_a}{ET_m} \right)$$

Where;  $K_y$  = yield response factor,  $Y_a$  = actual yield obtained from each deficit treatments (kg/ha),  $Y_m$  = maximum of maize yield obtained from the control treatment with full irrigation (kg/ha),  $ET_a$  = net depth of irrigation applied for each deficit treatments (mm),  $ET_m$  = net depth of irrigation water applied for the control treatment with full irrigation (mm),  $\left( 1 - \frac{Y_a}{Y_m} \right)$  = decrease in relative yield due to deficit water application and  $\left( 1 - \frac{ET_a}{ET_m} \right)$  = relative water saved (decrease in relative crop water consumptive) due to deficit irrigation.

## Economic Water Productivity

Economic analysis was done using the prevailing market prices during experimentation and at the time the crop was harvested. All costs and benefits were calculated on hectare basis in Ethiopian Birr (Birr/ha). The adjusted yield was obtained by reducing the average yield by 10% as indicated in CIMMYT (1988). The average cost the local people were paying for daily labor was 75.00 Birr per day. Thus, for computing the analysis labor cost of 75.00 Birr per day was used. The farm gate price of maize during the harvesting time was 10.50 Birr/Kg, the price of irrigation water was taken as 1.00 Birr per  $0.5 \text{ m}^3$  of water.

Net income (NI) in Birr/ha, generated from maize crop was computed by subtracting the total variable cost (TVC) in Birr/ha from the total return (TR) in Birr/ha from maize sale as,

$$\text{NIR} = \text{TR} - \text{TVC}$$

Fixed costs (FC) are those that do not vary between irrigation treatments, i.e. maize seeds, pesticides, land rent and farm implements. Variable costs (VC), on the other hand, are those that do vary between irrigation treatments, i.e. irrigation water and labor.

Percent marginal rate of return (MRR) was calculated by the following formula:

$$\text{MRR} = \frac{\Delta \text{NI}}{\Delta \text{VC}} \times 100\%$$

Where:  $\Delta \text{NI}$  is the difference of the net income in Birr and

$\Delta \text{VC}$  is additional unit of expense in Birr, between two consecutive undominated treatments.

## Statistical Analysis

The measured variables were subjected to analysis of variance for RCBD using SAS system for window 9.0. Significant mean separation was computed using List Significance difference (LSD) at 5% and 1% level of probability.

## Results and Discussion

### Description of the soil of Experimental Site

The result of the soil analysis from the experimental site showed that the average of sand, silt, and clay percentages were 23.67, 34.0, and 42.33 %, respectively and classified as clay loam texture (Table 1). The soil has average moisture content at Field Capacity (FC) and Permanent Wilting Point (PWP) were 39.2 % and 27.77 %, respectively. The total Available Water (TAW) was 142.89mm/m with bulk density of 1.25 g/cm<sup>3</sup> which was below the critical threshold level (1.4g/cm<sup>3</sup>) and was suitable for crop root growth (Table 1).

Table 1. Soil physical Properties of the experimental site

Soil Depth (cm)					Particle size Distribution (%)			Textural class
	BD (g/cm <sup>3</sup> )	FC (%)	PWP (%)	TAW (mm/m)	Sand	Clay	Silt	
0-20	1.3	38	27	143.33	23	41	36	Clay loam
20-40	1.24	39	28	136.32	23	43	34	Clay loam
40-60	1.21	41	28.3	148.89	25	43	32	Clay loam
Average	1.25	39.2	27.77	142.89	23.67	42.33	34.0	Clay loam

### Crop water requirement and irrigation schedule of maize

Crop water requirements and irrigation scheduling of maize were calculated by multiplying the reference evapotranspiration values with the onion crop coefficient Allen *et al.*, (1998) and computed as 518.72mm (5187.2m<sup>3</sup>/ha) under conventional furrow irrigation method. This result is agree with (FAO, 1977) ,they states that approximate value of seasonal crop water requirement of maize for maximum yields is 500 to 800 mm depending on climate. The net crop water requirement was computed by deducting effective rainfall from ETc while Gross water requirement was computed by adopting a field application efficiency of 60% were 416.53 mm and 694.21mm , respectively.



## **Effect of Deficit Irrigation levels on Yield and Yield Components of maize**

### ***Plant Height***

The analysis of variance indicated that there was highly significant difference on plant height due to the variation of different deficit irrigation application level ( $P < 0.01$ ) as shown Table (3). The highest plant height was recorded from control treatment which is 287.07cm while the minimum plant height 240.4cm was observed from T4 and this was significantly inferior to all other treatments. Generally, the mean plant height showed (Table 3) that, maize plant height was decreased as the stress level increased through the whole crop growing season. This due to higher plant height was associated with higher irrigation water application and shorter plant height was resulted because of application of minimum irrigation water. This result is in agreement with the finding of Dirirsa *et al.* (2017) and Mebrahtu *et al.* (2018).

### ***Cob length and Cob diameter***

The analysis of variance indicated that there was highly significant both Cob length and Cob diameter variation due to different deficit irrigation application level ( $P < 0.01$ ) as shown Table (3). The highest cob length was recorded from control treatment which is 25.25cm while the minimum cob length 16.97cm was observed from T4 and The highest cob diameter was recorded from control treatment which is 51.7cm while the minimum cob diameter 38.9cm was observed from T4.

### ***Grain Yield***

The analysis of variance has indicated that the effects of treatments on maize yield were highly statistically significant ( $P < 0.01$ ) as shown Table 3. Highest yield 5346.9 kg/ha was observed from the control treatment (T1) and the minimum yield 3061.5kg/ha was observed from T4. Comparable to the present observation water application with no deficit (100% ETC) at any stage of plant growth gave highest marketable yield (Patel and Rajput, 2013). Also Mekonen (2011) observed that water stress during different growth stages affected crop water productivity differently.

### **Crop Water Production Function (CWPF)**

The seasonal water use function obtained using seasonal evapotranspiration and grain yield of maize was presented in Figure 1. As shown in the figure, the applied water was utilized fully in the beginning and yield increased linearly. However, as it approached to peak, the yield increased with decreasing rate irrespective of the increase in water application. Seasonal crop evapotranspiration had best relation to grain yield ( $R^2 = 0.98$ ) (Figure 1). The values of the

coefficients; a, b and c were -0.0091, 1.5768 and -4.0695. The crop production function was given by;

$$Y = -0.0091(P + I)^2 + 1.5768(P + I) - 4.0695$$

Where: Y = grain yield (Qt/ha), p = effective rainfall (cm) and I = net irrigation water (cm)

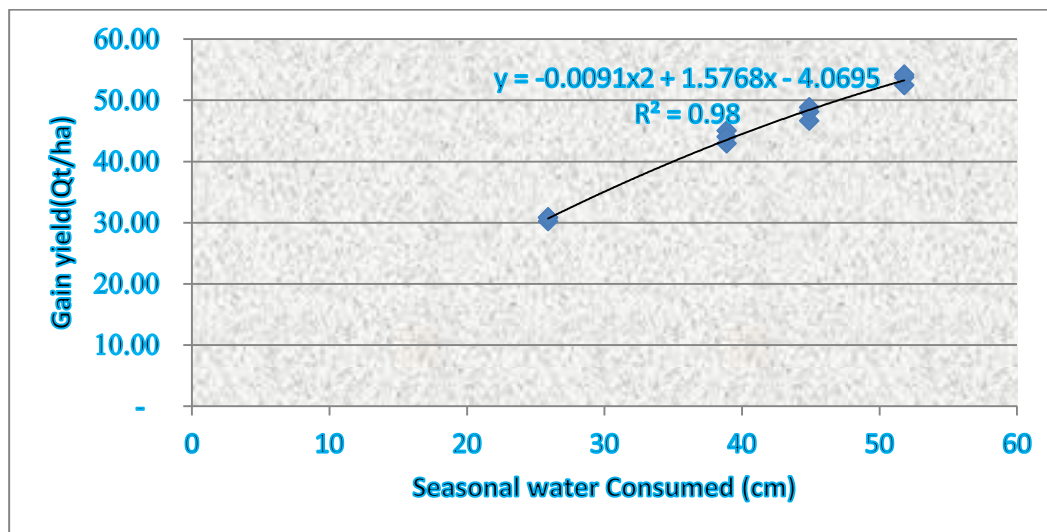

Figure 1. Water production function of maize crop based of seasonal water consumed

## Effect of Deficit Irrigation level on Water use Efficiency

### *Crop water use efficiency and irrigation water use efficiency*

Analysis of variance indicated that the effect of deficit irrigation levels on crop water use efficiency were highly significant ( $P < 0.01$ ). In this experiment, the mean crop water use efficiency of maize varied from 1.29kg/ha/mm to 1.42 kg/ha/mm (Table 3). The highest CWUE (1.43kg/ha/mm) was obtained at T4 and the lowest mean value of CWUE (1.29kg/ha/mm) was obtained under full irrigation water application (T1). In general, the result revealed that with decreasing the amount of water supply through whole growing season or at growth stages, the crop water use efficiency increases (Table 3). This result is in line with the result of (Samson and Ketema ,2007).

Analysis of variance indicated that the effect of deficit irrigation levels on irrigation water use efficiency were highly significant ( $P < 0.01$ ). As shown in Table 3, the highest irrigation water use efficiency (1.08kg/m<sup>3</sup>) was obtained under T4 and statistically had highly significant difference ( $p < 0.01$ ) to all other treatments. This shows that treatments with lower yield due to less water application had higher irrigation water use efficiency. The lowest irrigation water use efficiency (0.94kg/m<sup>3</sup>) was obtained from T1. This result is in agreement with (Sarkar *et*

al. 2008) reported that irrigation water use efficiency was higher at lower levels of available soil moisture. The result related to the water use efficiencies showed that in area where irrigation water is limited, 75% ETC deficit irrigation levels can be applied by increasing the water use efficiencies with significant and tolerable yield reduction.

Therefore, for this particular maize variety (shoney) it could be concluded that applying 75% ETC deficit irrigation level applied through whole growing under conventional furrow irrigation system saved water 128.9mm (1288.8m<sup>3</sup>/ha) compared to full irrigation level, which be used for downstream water user in the irrigation scheme by pumping the water for the same crop under similar climatic condition around the study area.

Table 3. Effect of Deficit irrigation levels on yield and water use efficiency of maize

Treatment	Irrigation water applied(m <sup>3</sup> /ha)	PH (cm)	CL (cm)	CD (cm)	Yield (kg/ha)	CWUE (kg/ha/mm)	IWUE Kg/m <sup>3</sup>	Water saved (m <sup>3</sup> /ha)
T1	5187.2	287.07A	25.25H	51.73L	5346.9G	1.29C	0.94 K	
T2	4, 409.12	275.47B	23.22I	48.53M	4786.9F	1.35E	0.99J	778.08
T3	3898.4	264.40C	21.15J	45.73N	4399.3T	1.39E	1.03L	1288.8
T4	2593.8	240.47D	16.97K	38.93P	3061.3S	1.42B	1.08M	2593.4
LSD(0.05)	1.35	1.87	0.77	1.59	1.97	1.56	1.9	
CV	2.3	3.75	2.79	3.4	5.8	2.69	2.79	

**Note:** The letters indicate the significance relation of treatments. Treatment shown the same letter are not significantly different. LSD = least significant difference; CV = Coefficient of variation. T1 = 100% ETc, T2 = 85% ETc, T3 = 75% ETc, T4 = 50% ETc

### Yield Response Factor (K<sub>y</sub>)

The relationship between relative yield reduction and relative evapotranspiration deficit for maize yield was estimated. As shown in the Table 4 below, the relative yield reduction increased with increasing relative evapotranspiration deficit. Observed yield response factors (K<sub>y</sub>) of T2, T3, T4, T5 and T6 were 0.68, 0.62, 0.57, 0.61 and 0.65 respectively which is less than one (Table 4). This shows that deficit levels distributed during whole growing season or at growth stages could tolerate yield reduction (K<sub>y</sub> < 1) during cropping season in the area. This result is in line with (Doorenbos and Kassam, 1979). The results of this study reveals that , increasing water deficit throughout the whole growing season caused decreasing of K<sub>y</sub> values, but increasing water deficit during a specific growth stages (initial, development, mid and late stages) caused increasing of K<sub>y</sub> values(Table 4).

Table 4. Deficit irrigation effect on yield response factor of maize

Treatment	Yield(kg/ha)	ETa(mm)	$\frac{ET_a}{ET_m}$	$\frac{y_a}{y_m}$	$1 - \frac{ET_a}{ET_m}$	$1 - \frac{y_a}{y_m}$	ky
T1	5,346.90	518.70	1.00	1.00	0.00	0.00	-
T2	4,786.90	440.90	0.85	0.90	0.15	0.10	0.70
T3	4,399.30	389.80	0.75	0.82	0.25	0.18	0.71
T4	3,061.30	259.40	0.50	0.57	0.50	0.43	0.86

Where:  $1 - \frac{ET_a}{ET_m}$  = Relative evapotranspiration deficit,  $(1 - \frac{y_a}{y_m})$  = Relative yield reduction,

ETa = the net depth of Irrigation applied for each deficit treatments (mm),

ETm = net depth of irrigation water applied for the control treatment with full irrigation (mm),

Ky = Yield response factor

Stressed treatments with irrigation application under T2, T3 and T4 showed a yield reduction of 10%, 18% and 43%, respectively compared with the 100% ETc (T1) irrigation water application. This indicates a linear relationship between the decrease in relative water use and the decrease in relative yield (Figure 2).

This relation is closely in line with (Bhagyawant *et al.*, 2015).

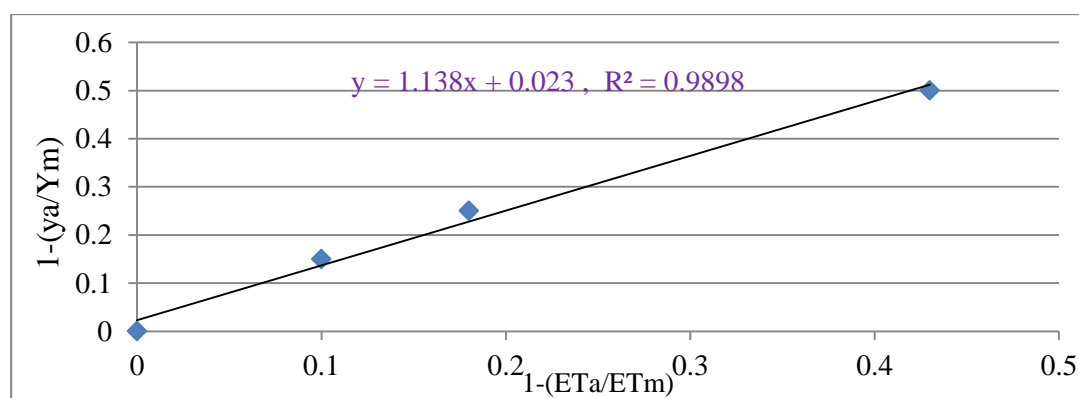

Figure 2. Relationship between relative yield reduction & relative evapotranspiration deficit for maize

### Economic Analysis

The partial budget analysis revealed that the highest net benefit of 30,840.42 ETB/ha with higher cost was recorded from T1 with marginal rate of return 297.83% which was followed by net benefit of 26,878.63 ETB/ha from T2 with marginal rate of return 150.68%. However, the highest net benefits of 24,676.97 ETB/ha with cost production of about 16896.42 ETB/ha was obtained from T3 with its marginal rate of return 289.47%. This means

that for every Birr 1.00 invested in T3, growers can expect to recover the Birr 1.00 and obtain an additional Birr 2.8947.

The minimum acceptable marginal rate of return (MRR %) should be between 50% and 100% CIMMYT (1988). Thus, the current study indicated that marginal rate of return is higher than 100% (Table 5). This showed that all the treatments are economically important as per the MRR is greater than 100%. Hence, the most economically attractive for small scale farmers with low cost of production and higher net benefit was obtained by application of T3 under conventional furrow irrigation system. However, for resource full farmers or in areas where water is not limiting factor for crop production, application of 100% (T1) is highly profitable with higher cost which is recommended as a second option.

Table 5 . Economic analysis of maize production under different deficit irrigation treatments

Treatmt	Irrigation water applied (m <sup>3</sup> /ha)	Average yield (ton/ha)	Adjusted yield (ton/ha)	Total return (ETB/ha)	Variable cost (ETB/ha)	Net income (ETB/ha)	MRR(%)
T1	5,187.20	5.3469	4.81221	50,528.21	19687.79	30,840.42	297.83
T2	4,409.12	4.7869	4.30821	45,236.21	18357.58	26,878.63	150.68
T3	3898.40	4.3993	3.95937	41,573.39	16896.42	24,676.97	289.47
T4	2593.80	3.0613	2.75517	28,929.29	13649.89	15,279.40	-

MRR = Marginal Return Rate, ETB = Ethiopian birr

### Conclusions and Recommendations

This study was proposed to investigate the deficit irrigation effect on yield and water productivity of maize under conventional furrow irrigation system. The field experiment consist of treatments with different level of deficit irrigation water application throughout crop growth season (T1 = 100% ET<sub>c</sub>, T2 = 85% ET<sub>c</sub>, T3 = 75% ET<sub>c</sub>, T4 = 50% ET<sub>c</sub>). The treatments were assigned in Randomized Complete Block Design with three replications. As result revealed that, all deficit irrigation treatments had highly significant effect ( $p < 0.01$ ) on yield and yield components and water use efficiency of maize. Thus, total maize yield and WUE was varied under different deficit irrigation levels. The highest and the lowest maize yield were recorded from T1 and T4 , respectively. Similarly, the highest IWUE and CWUE were obtained from T4 while the lowest one recorded from T1. But, at T4, T3 and T2 highly yield reduction was observed compare to T1 which may not be attractive for farmers. Therefore, for this particular maize variety (shoney) it could be concluded that applying 75% ET<sub>c</sub> deficit irrigation level through whole growing under conventional furrow irrigation system saved water 128.9mm (1288.8m<sup>3</sup>/ha) or 0.33ha additional area can be irrigated by the

amount of saved water compared to full irrigation level, which used for downstream water user in the irrigation scheme by pumping the water for the same crop under similar climatic condition around the study area.

### **Acknowledgements**

The authors would like to acknowledge Oromia Agricultural Research Institute providing the required budget to conduct the experiment. Besides, I would like to thanks the Soil laboratory technicians of Oromia Water Works Design and Supervision Enterprise and Bako Agricultural Research Center for their effective and enthusiastic work in soil analysis.

### **References**

- Allen, R.G., L.S. Pereira, D. Raes and M. Smith, 1998. Crop Evapotranspiration Guidelines for Calculating Crop Water Requirements. FAO Irrigation and Drainage Paper 56. FAO, Rome, Italy.
- Bhagyawant, R. G. Gorantiwar, S. D. Dahiwalkar, S. D. Bhalekar, M. N. and Khedkar, D. D. 2015. Yield Response Factor for Onion (*Allium Cepa L*) Crop under Deficit Irrigation in Semiarid Tropics of Maharashtra. *Curr. Agri. Res. Jour.*, Vol. 3(2), 128-136 (2015).
- CIMMYT (International Maize and Wheat Improvement Center). 1988. From agronomic data to farmer recommendations: An economics-training manual. Completely Revised Edition. CIMMYT, D.F, Mexico.
- Doorenbos, J. and A.H. Kassam.1979. Yield response to water. FAO irrigation and drainage No. 33. FAO, Rome, Italy, 194p.
- Dirirsa, G., Woldemichael A. and Hordofa T. 2017. Effect of Deficit Irrigation at Different Growth Stages on Onion (*Allium Cepa L.*) Production and Water Productivity at Melkassa, Central Rift Valley of Ethiopia. *Acad. Res. J. Agri. Sci. Res.* 5(5): 358-365.
- FAO (Food and Agriculture Organization).1977. Crop water requirements. FAO Irrigation and drainage paper 24, Rome.
- FAO (Food and Agricultural Organization). 2009. CropWat for windows version 8.0. FAO, Rome, Italy. FAO.
- Igbadun, H.E., A.K.P.R. Tarimo, B.A. Salim, and H.F. Mahoo, 2007. Evaluation of selected crop water production functions for an irrigated maize crop. *Agri. Water Manage.* 94:1–10.
- Kandiah, A. 1981. Guide for measurement of irrigation water using Parshall flumes and siphons. Technical Bulletin no.1 Irrigation Agronomy Section Melka Werer Research Station Institute of Agricultural Research, FAO irrigation Specialist. Addis Ababa.
- Mebrahtu, Y. Woldemichael A. and Habtu S. 2018. Response of onion (*Allium cepa l.*) to deficit irrigation under different furrow irrigation water management techniques in Raya Valley, Northern Ethiopia. *African Journal of Plant Science (ISSN 1996-0824)* Vol. 12(5), pp. 105-113.
- Mekonen Ayana. 2011. Deficit irrigation practices as alternative means of improving water use efficiencies in irrigated agriculture: Case study of maize crop at Arba Minch, Ethiopia. *African J. of Agri. Res.* 6(2): 226-235.
- Samson Bekele and Ketema Tilahun, 2007. Regulated deficit irrigation scheduling of onion in a semiarid region of Ethiopia. *Agricultural Water Management* 89: 148-152.
- Sarkar, S., S. B. Goswami, S. Mallick and M. K.Nanda, 2008. Different indices to characterize water use pattern of micro sprinkler irrigated onion (*Allium cepa L.*). *Agricultural Water*

- Management, 95: 625-632.
- Seleshi Bekele , Awulachew and Mekonnen Ayana, 2011. Performance of irrigation: An assessment at different scales in Ethiopia. *Expl. Agri.* 47 (SI) : 57–69.
- Sisay Demeku Dirib, K. Descheemaeker, Amare Hailelassie and Tilahun Amade, 2011. Irrigation water productivity as affected by water management in a small-scale irrigation scheme in the Blue Nile Basin, Ethiopia. *Expl. Agri.* 47 (SI): 39–55.
- Patel and Rajput. 2013. Effect of deficit irrigation on crop growth, yield and quality of onion in sub-surface drip irrigation. *International Journal of Plant Production*, 7(3): 1735 8043.

# Effect of Alternate furrow irrigation with different irrigation intervals on yield, water use efficiency, and economic return of green Cob Maize (*Zea mays*) production at Wayu Tuka and Diga Districts, Western Oromia

Adisu Tadese\*, Lema Teklu

Oromia Agricultural Research Institute, Bako Agricultural Research Centre, Oromia, Ethiopia. Corresponding author: e-mail: [addisswem@gmail.com](mailto:addisswem@gmail.com)

## Abstract

Alternate furrow irrigation with proper irrigation intervals could save irrigation water and result in high yield with minimum irrigation water and costs during dry season. Field experiment was conducted at two locations for two consecutive years to investigate the effect of alternate furrow irrigation with irrigation intervals (AFI with normal, reduced and extended irrigation intervals) on yield, water productivity and economic return of maize (*Zea mays* L.) as compared with every-furrow irrigation (EFI, conventional method with normal irrigation interval). Normal irrigation interval is irrigation interval produced by CROPWAT model. Results indicated that highest green cob yield 10733/ha and 10822/ha at Diga and 10044/ha and 10200/ha were obtained from AFI with normal irrigation interval treatment during two consecutive seasons whereas, low number are collected from Farmer practice (FP) treatments. However, highest water productivity (WP) values ( $3.42\text{kg/m}^3$ ,  $3.45\text{ kg/m}^3$ ,  $3.55\text{kg/m}^3$  and  $3.30\text{kg/m}^3$ ) were observed from AFI with extended irrigation interval at both locations during consecutive growing seasons. Irrigation water saved at Wayu Tuka under  $AFI_{norm}$  and  $AFI_{extended}$  treatments were approximately 50% and 60% respectively, as compared to the CFI treatment and 43.6 and 55.7%  $AFI_{norm}$  and  $AFI_{extended}$  treatments respectively at Diga site. However, under  $AFI_{extended}$  yield reduction was observed as compared with  $AFI_{norm}$ . It could be concluded that Alternate-furrow irrigation with normal irrigation interval can improve crop water productivity without the risk of yield reduction. Therefore, if low cost water is available and excess water delivery to the field does not require any additional expense, then the AFI normal irrigation interval treatment will essentially be the best choice under the study area conditions.

**Key words:** Alternate Furrow, Irrigation interval, Water productivity, green crop yield

## Introduction

Irrigated agriculture is the main solution to produce crop to feed and achieve the different needs for an ever-increasing world population. However, a Growing competition for water from domestic and industrial sectors reduced its availability for irrigation. In this regards irrigation only based on crop water requirement is not an option especially in areas where water resource is limited. Much of an increase in the irrigated area had come because of the expansion of small-scale irrigation in the country. Yet, the existing irrigation development in



Ethiopia, as compared to the resources the country has, is negligible. Irrigation water management implies the application of suitable water to crops in right amount at the right time. Salient features of any improved method of irrigation is the controlled application of the required amount of water at desired time, which leads to minimization of range of variation of the moisture content in the root zone, thus reducing stress on the plants (Monteith, 1990 and Ulsido and Alemu, 2014). Many investigations have been conducted to gain experiences in irrigation of crops to maximize performance, efficiencies and profitability. However, investigation in water saving irrigation still is continued (sleeper *et al.*, 2007).

Satisfying crop water requirements, although it maximizes production from the land unit, does not necessarily maximize the return per unit volume of water (Oweis *et al.*, 2000 and Oweis *et al.*, 1998). The target crop maize is the one of the major crop in Ethiopia with is the top crop by the number of farming community engaged and next to teff it is the highest in area coverage in the country (Oweis *et al.*, 2000). The study area is at Western Ethiopia where crop production in wet season by rain fall and during dry season is unexpected without irrigation. Moreover, it is characterized by having highly variable initial and conditional probability of threshold limit of 30 mm per decade rainfall in the main rainy season (Oweis *et al.*, 1998).

To improve crop production to feed the ever-increasing population under limiting water resource condition, strategies that conserve moisture in the soil and efficient irrigation techniques should be identified and practiced. Different works have been done on irrigation water management for maize in different part of the world that revealed that yield and water productivity of maize enhanced through different irrigation water management methods like conventional furrow, alternate furrow and water conservation methods like application of straw and plastic mulching (Mebrahtu, 2017 and Penman 1948).

Application of irrigation water through conventional furrow method that irrigate all the neighbouring furrow in two consecutive irrigation time leads to maximize yield under different crops including maize. However, productivity of irrigation water is maximized through deficit irrigation practice using different techniques like alternate furrow method by irrigating only one of the neighbouring two furrows during the consecutive irrigation time. For example, (Seid Debaeke and Aboudrare, 2004) reported that maximum maize yield was obtained under conventional furrow irrigation with irrigation water application of 100% crop water requirement than the alternate and fixed furrow irrigation method. The same research revealed that with comparable yield penalty, alternate furrow irrigation method maximized

water use efficiency of maize. According to (Nasri *et al.*, 2010) that reported alternate partial root-zone irrigation improves water use efficiency of okra plant than the conventional furrow condition under different soil moisture depletion levels. Based on their findings, they concluded that alternate furrow irrigation as a way to save water and maize production relies heavily on repeated irrigation.

Alternate furrow irrigation (AFI) is considered to be one of the most effective tools to minimize water application and irrigation costs and produce a higher crop yield. The AFI method is a way to save irrigation water, improve irrigation efficiency, and increase corn yield (Shayannejad and Moharreri, 2009; Nasri *et al.*, 2010; Rafiee and Shakarami, 2010; Kashiani *et al.*, 2011). Using Alternate furrow irrigation with appropriate irrigation interval can save irrigation water without yield reduction. Little works were done on irrigation interval of Alternate furrow irrigation. Sepaskhah and Khajehabdollahi (2005) found that corn grain yield of AFI at 7-d intervals was lower than every-furrow irrigation (EFI) at 10-d intervals.

In addition, Li *et al.* (2007) found that alternate partial root-zone and fixed partial root-zone irrigation techniques led to a higher reduction of transpiration than photosynthesis and thus increased corn leaf water use efficiency (WUE). Beside this, Abdel-Maksoud *et al.* (2002) found that AFI at 14-d intervals seemed to not significantly decrease yield, whereas yield increased under AFI at 7-d intervals as compared with the EFI method.

Therefore, in an effort to improving water productivity through Alternate furrow irrigation with appropriate irrigation interval is an interest of the study done on maize crop.

The objective of this research study was to investigate the effects of alternate furrow irrigation with different irrigation intervals on corn yield, irrigation water productivity, and economic return as compared with EFI (conventional method).

## **Materials and Method**

### **Description of the study area**

This experiment was conducted in Dida and Wayu Tuka Districts of western Oromia. The study sites are Lelisa Dimtu from Diga District and Xaxo from Wayu Tuka. Diga and Wayu Tuka districts were located at 338 and 325km from Addis Ababa respectively. The districts have three agro ecologies Dega, weyna and Kola.

## Treatments and experimental design

Irrigation treatments were: 1, Farmer practice (FP); 2, Conventional irrigation method (EFI), every furrow was irrigated at CROPWAT irrigation interval; 3, Alternate furrow irrigation at CROPWAT irrigation interval ( $AFI_{norm}$ ); 4, Alternate furrow irrigation at Reduced CROPWAT irrigation interval ( $AFI_{reduced}$ ); and 5, Alternate furrow irrigation at extended CROPWAT irrigation interval ( $AFI_{extended}$ ). The adopted treatments were assessed with randomized complete block design (RCBD) with three replicates.

The experimental plot size was  $45m^2$  (10m wide  $\times$  4.5m long). Each treatment included 7 furrows and 6 planting ridges (rows). Furrow spacing was 0.75 m. Space between plots been 1m and between replication 1.5 m. Space between rows 0.75m and 0.35cm between the plants was used. The experimental plot was pre-irrigated one day before planting. Before the commencement of treatment, two to three common light irrigations was supplied to all plots at two to three days interval to ensure better plant establishment.

Table 1. Treatment set-up

Treatment Code	Treatment combination
FP	Farmer practice
EFI	Convectional furrow irrigation (CROPWAT irrigation interval)
$AFI_{norm}$	Alternate furrow irrigation (CROPWAT irrigation interval)
$AFI_{reduced}$	Alternate furrow irrigation (Reduced CROPWAT irrigation interval)
$AFI_{extended}$	Alternate furrow irrigation (Extended CROPWAT irrigation interval)

## Agronomic practices

Agronomic practices maize seeds (BH-546) were planted during 2018/19 and 2019/20 growing seasons at the rate of  $25kg/ha^{-1}$ . Two seeds were planted per hole with a plant spacing of 0.35m. All plots were irrigated immediately after planting (planting irrigation). Recommended fertilizer of 100kg/ha NPS and half of 200kg/ha UREA was applied prior to the second pre-treatment irrigation. Thinning was carried out after the second pre-treatment irrigation and the remains half UREA was applied after 35 days of planting. All other agricultural operations, including pesticide and hand weeding, were applied uniformly and simultaneously for all treatments. Experimental treatments were implemented after the second pre-treatment irrigation in both seasons.

## Crop water requirement and Irrigation Schedule

The estimate of the water requirement and irrigation scheduling of crops under this study is based on the atmospheric conditions of the environment by using a model. A computer

program called “CROPWAT version 8.0” was used to determine reference evapotranspiration, crop water requirements, and irrigation schedule by utilizing metrological data as an input. For estimation of water irrigation requirements, climatic, crop and soil data have been utilized as an input. This calculation has been done by using the FAO Penman-Monteith method (Aallen 1998). In this experiment, the reference evapotranspiration (ET<sub>o</sub>) and crop water requirement (ET<sub>c</sub>) were estimated from long term climatic data collected from Ethiopia Metrological Agency.

Irrigation water was conveyed to the experimental plots through Parshall Flume having appropriate opening diameter of three inch (3") and a length of 2 m. The amount of water for each application was added through Parshall Flume by recording time of water flow through furrows. Time is then recorded with a stopwatch to estimate the amount of water applied to each plot. Furrows subjected to irrigation were close-ended; then, water cannot exceed the edge of the plot because all were closed-ended. The water in the channel was controlled to maintain a constant head to provide an adequate inflow rate during irrigation events with a close ended.

## **Data Collection**

### ***Climatic data***

Before the start of the experiment, secondary data such as climatic data of 30 years on rainfall (R.F.) min and max temperature, relative humidity (RH), wind speed (WS) and sunshine hours (SH) were collected from the National meteorological agency. Irrigation efficiency for furrow irrigation, root depth of maize crop, maize crop growth stages and their respective length of period data were also collected from previous records and FAO guidelines.

### ***Soil Physical Properties***

Four soil profiles were randomly made in the experimental site to measure soil physical properties. Soil texture was determined using the volumetric method at 0-5, 5-10, 10-15 and 15-20cm depths of the soil profiles. Bulk density was determined by the core method (Blake and Hartage 1986) for each sampling depth. Soil water content was determined from soil samples taken at the same locations using the gravimetric method. The soil basic infiltration rate was determined in the field using double-ring infiltrometer method in two separate sites in the experimental area as described by (Bouwer 1986).

Table 2. Soil physical characteristics of the experimental sites

Sampling Depth	Wayu Tuka (Lega Xaxo)			Diga (Lelisa Dimtu)		
	Bulk density	Average bulk density g/cm <sup>3</sup>	Soil texture	Bulk density	Average bulk density g/cm <sup>3</sup>	Soil texture
0-5cm	1.32	1.34	clay	1.18	1.31	Sandy clay
5-10cm	1.34			1.29		
10-15cm	1.36			1.38		
15-20cm	1.37			1.4		
FC (%)	61.72			52.6		
PWP (%)	50.18			34.87		

### Yield and Yield Components

Yield (green cob) data, were collected from each plot size of 10 \*4.5m and extrapolated to a hectare basis. Green Cobs of maize were categorized as small, medium and large based on the size of cobs and data were collected in number and weight basis from each plot at both locations. Stand count data was also collected from all plots at maturity stage.

### Water Productivity

Water productivity (WP) Water productivity was determined by dividing grain yield by total applied irrigation water and is expressed as follows (Ali et al., 2007):

$$WP = GY/Wa \quad (1)$$

Where: GY is grain yield (kg ha<sup>-1</sup>)

Wa is irrigation applied water (m<sup>3</sup> ha<sup>-1</sup>).

### Data Analysis

The collected data was subjected to analysis of variance (ANOVA) and least significant difference (LSD) was used to separate means at p<0.05 probability levels of significance.

## Result and Discussion

In order to characterize soils of the study site, soil physical and chemical parameters were measured in the field and laboratory. The laboratory results of the average chemical properties of the experimental site were presented in table 3. The result of the soil analysis from the experimental site showed that the top soil surface had bulk densities were of 1.34gm/cm<sup>3</sup> and 1.31gm/cm<sup>3</sup> at Wayu Tuka (Xaxo) and Diga (Lelisa Dimtu) sites respectively. In general, the

average soil bulk density ( $1.31\text{gm/m}^3$ ) is below the critical threshold level ( $1.4\text{g/cm}^3$ ) and was suitable for crop root growth. Average moisture content at field capacity of the experimental sites soils were 61.72% and 52.6% at Xao and Lelisa Dimtu sites respectively, and permanent wilting point the sites were 50.18% and 34.87% at Xaxo and Lelisa Dimtu respectively. Soil pH was found to be at slightly acidic value (5.7 averages of all treatments) at both sites for maize and other crops. Therefore, the soils of the study area are normal soils. The weighted average organic matter content of the soil was 5.3 and 5.6% at Xaxo and Lelisa Dimtu respectively.

Table 3. Soil chemical properties characteristics of the experimental sites

Treatments	Wayu Tuka (Lega Xaxo)					Diga (Lelisa Dimtu)				
	pH(1:2.5) H <sub>2</sub> O	OC (%)	OM (%)	TN %	Av.P (ppm)	pH(1:2.5) H <sub>2</sub> O	OC (%)	OM (%)	TN %	Av.P (ppm)
CFI	5.64	2.83	4.87	0.14	16.7	5.61	2.91	5.01	0.15	24.7
AFI <sub>Norm</sub>	5.68	3.24	5.58	0.18	15.6	5.86	3.26	5.61	0.18	19.7
AFI <sub>Extend</sub>	5.5	3.14	5.41	0.17	12.7	5.64	2.87	4.94	0.15	25.7
AFI <sub>Redu</sub>	5.84	2.69	4.64	0.13	29.6	5.71	4.04	6.96	0.25	18.1

### Depth of applied water

Table.4. Number of irrigation events & depth of applied water for each irrigation event at Wayu Tuka

Irrigation event	Wayu Tuka (Lega Xaxo)									
	Depth of applied water (Wa) (mm)									
	Season 2018/19					Season 2019/20				
	FP	CFI	AFINorm	AFIExtend	AFIRedu	FP	CFI	AFINorm	AFIExtend	AFIRedu
1	37.1	30.9	15.4	18.7	11.8	38.9	32.4	16.2	19.6	12.3
2	44.8	37.3	18.6	25.7	9.8	46.9	39.2	19.6	22.7	10.2
3	51	42.5	21.3	24.5	12.7	53.6	44.6	22.3	23	13.3
4	51.9	43.3	21.7	27.2	15.5	54.6	45.5	22.7	23.3	16.2
5	52.7	43.9	21.9	26.3	18.7	55.3	46.1	23	26.5	19.6
6	53.2	44.3	22.2	26	21.3	55.8	46.5	23.3	27	22.3
7	53.3	44.4	22.2	26.7	21.7	55.9	46.6	23.3	25.4	22.7
8	60.6	50.5	25.3	24	21.9	63.6	53	26.5	23.2	23
9	56.7	50	26	23	22.2	58.7	54	25.4	22.4	23.3
10	61.4	51.4	26.4	-	22.2	62.5	53.6	23	-	23.3
11	60.8	50	25	-	25.3	61.2	52	22.6	-	26.5
12	60.6	46	22		25.3	60.6	47.4	22.3		26.3
13	61.3				22	60.4				23.4
14	56				21.4	58				23
15	53.4				20	55.4				22
Total	814.8	534.5	268	222.1	291.8	841.4	560.9	270.2	213.1	307.4

The irrigation events and amount of applied water (Wa) for each treatment at Wayu Tuka district of Lega Xaxo site are shown in Table 4. The AFI<sub>Redu</sub> (Altenat Furrow irrigation with reduced irrigation interval) treatment was more frequent (15 irrigation events) than CFI and AFI<sub>Norm</sub> (twelve irrigation events) for both seasons. This indicates that the AFI<sub>Extend</sub> and AFI<sub>Norm</sub> alternate furrow irrigation treatments saved water by approximately 60% and 50% (two-season means), respectively, as compared to conventional CFI. Regardless of irrigation intervals, the lowest amount of applied water (Wa) under AFI<sub>Norm</sub> treatments as compared with CFI might be due to the great reduction of wetted surface in AFI<sub>Norm</sub>; almost half of the soil surface is wetted in AFI<sub>Norm</sub> as compared with CFI. This result supports the outcome obtained by (Awad Abd El-Halim, 2013), who found that AFI methods can supply water in a way that greatly reduces the amount of wetted surface, which leads to less evapotranspiration and less deep percolation.

Table.5. Number of irrigation events and depth of applied water for each irrigation event at Diga

Irrigation events	Diga (Lelisa Dimtu)									
	Depth of applied water (mm)									
	Season 2018/19					Season 2019/20				
	FP	CFI	AFINorm	AFIExtend	AFIRedu	FP	CFI	AFINorm	AFIExtend	AFIRedu
1	43.1	36.9	21.5	24.7	17.8	46.9	40.4	24.2	27.6	20.3
2	50.9	43.3	24.7	27.7	15.8	54.9	47.2	27.6	30.7	18.2
3	57	48.5	27.3	27.9	18.7	61.6	52.6	30.3	31	21.3
4	57.9	49.3	27.7	28.2	21.5	62.6	53.3	30.7	31.3	24.2
5	58.7	49.9	27.9	31.3	24.7	63.3	54.1	31	34.5	27.6
6	59.2	50.3	28.2	32	27.3	63.8	54.5	31.3	35	30.3
7	59.3	50.4	28.2	29.4	27.7	63.9	54.6	31.3	32.5	30.7
8	66.6	56.5	31.3	27.2	27.9	71.6	61	34.5	30.3	31
9	62.5	57.4	32	25.3	28.2	68.4	62	34	28.5	31.3
10	61.2	53	29	-	28.2	67.6	61.3	32.4	-	31.3
11	63.3	52.4	27.4	-	31.3	66.7	58	30.4	-	34.5
12	64	50.4	25		31	65	57.4	28.6		34
13	61.4				30.4	63.5				32.6
14	60				28.3	62				30.4
15	58.4				27	59.5				28.6
Total	883.5	598.3	330.2	253.7	385.8	941.3	656.4	366.3	281.4	426.3

The irrigation events and amount of applied water (Wa) for each treatment at Diga district of Lalisa Dimtu site are shown in Table 5. The AFI<sub>Redu</sub> (Altenat Furrow irrigation with reduced irrigation interval) treatment was more frequent (15 irrigation events) than CFI and AFI<sub>Norm</sub> (eight irrigation events) for both seasons. This indicates that the AFI<sub>Extend</sub> and AFI<sub>Norm</sub> alternate furrow irrigation treatments saved water by approximately 55.7% and 43.6% (two-

season means), respectively, as compared to conventional CFI. Amount of water saved under AFI<sub>Extend</sub> and AFI<sub>Norm</sub> at Lelisa Dimtu site was relatively low as compared to Lega Xaxo Site. Amount of water applied under alternate furrow irrigation also agrees with the conclusion that says that alternate furrow irrigation is commonly applied as part of a deficit irrigation program because it does not require the application of more than 50–70% of the water used in a conventional furrow irrigation method (Webber et al 2006).

Table.6. Number of irrigation events and depth of applied water for each irrigation event under different irrigation treatments for both seasons at Diga

Irrigation events	Diga (Lelisa Dimtu)									
	Depth of applied water (mm)									
	Season 2018/19					Season 2019/20				
	FP	CFI	AFI <sub>Norm</sub>	AFI <sub>Extend</sub>	AFI <sub>Redu</sub>	FP	CFI	AFI <sub>Norm</sub>	AFI <sub>Extend</sub>	AFI <sub>Redu</sub>
1	43.1	36.9	21.5	24.7	17.8	46.9	40.4	24.2	27.6	20.3
2	50.9	43.3	24.7	27.7	15.8	54.9	47.2	27.6	30.7	18.2
3	57	48.5	27.3	27.9	18.7	61.6	52.6	30.3	31.0	21.3
4	57.9	49.3	27.7	28.2	21.5	62.6	53.3	30.7	31.3	24.2
5	58.7	49.9	27.9	31.3	24.7	63.3	54.1	31.0	34.5	27.6
6	59.2	50.3	28.2	-	27.3	63.8	54.5	31.3	-	30.3
7	59.3	50.4	28.2	-	27.7	63.9	54.6	31.3	-	30.7
8	66.6	56.5	31.3	-	27.9	71.6	61.0	34.5	-	31.0
9	62.5	-	-	-	28.2	68.4	-	-	-	31.3
10	61.2	-	-	-	28.2	67.6	-	-	-	31.3
11	63.3	-	-	-	31.3	66.7	-	-	-	34.5
Total	640	385	217	140	269	691	418	241	155	300.8
Mean of the two seasons	665	402	229	145	285					

### Yield (Green Cobs) and Stand count

At maturity stage of the crop numbers of cobs were counted for all plots and categorized to three groups (small, medium and large) based on the size of cobs. Based this, Number of cobs categorized as small, medium and large size were collected from each plot was significantly affected by the irrigation treatments and had the same trend in both seasons (Table 6).

The highest number of cobs 483 per plot (107333 per hectare) and 487 per plot (108222 per hectare) were recorded from AFI<sub>Norm</sub> for both seasons respectively followed by AFI<sub>Redu</sub> at Lelisa Dimtu Site. Numbers of cobs recorded from AFI<sub>Norm</sub> were higher than for CFI with 9111 to 9333 numbers per hectare in both seasons. Beside this, statistical analysis showed that stand count of maize had not affected by the application of different irrigation systems with different irrigation intervals ( $p < 0.05$ ). The lowest number of cobs per plant 438 per plot (97333 per hectare) and 441 per plot (98000 per hectare) were recorded from FP for both



seasons respectively at Lelisa Dimtu site. Numbers of cobs  $AFI_{Extend}$  were higher than CFI for in both seasons. When comparing CFI and  $AF_{norm}$ , the latter increased number of green cobs by approximately 667/ha and 889 in the first and second seasons respectively.

Table.7. Average number of cobs (green cobs) under different irrigation treatments at Lelisa Dimtu during 2018/19 and 2019/20

Treatment	Diga ( Lelisa Dimtu)									
	Season 2018/19					Season 2019/20				
	Stand count	Number of cobs per plot			Total number of cobs/ ha	Stand count	Number of cobs per plot			Total number of cobs per ha
small		Mediu m	Large	small			mediu m	Large		
FP	160.7a	65c	131.3c	241.7b	97333d	160.7a	65c	132.3c	243.7b	98000d
CFI	162.7a	65.7bc	132.7c	243.7b	98222d	162.7a	65.7c	133.7c	246.7b	98889d
$AFI_{Norm}$	164.7a	66.7a	146.3a	270a	107333a	164.7a	69.7a	148.3a	275a	108222a
$AFI_{Extend}$	163.7a	66.3ab	136b	248.7b	100222b	163.7a	67.3b	138b	250.7b	100889c
$AFI_{Redu}$	162.3a	66.0ab	137.3b	262.7a	103556b	162.3a	67.0b	137.3b	269.7a	104444b
CV	11.6	14.6	11.7	16.8	14.6	12.8	14.6	15.7	13.8	14.6
LSD	5.06	0.91	2.8	8	1867	5.06	1.5	2.8	8	1867

**Note:** FP; Farmer Practice, CFI; Convectional Furrow Irrigation,  $AFI_{Norm}$ ; Alternate Furrow irrigation with normal irrigation Interval,  $AFI_{Extend}$ ; Alternate furrow irrigation with extended irrigation interval,  $AFI_{Redu}$ ; Alternate furrow irrigation with reduced irrigation interval, CV; Coefficient of Variance and LSD; least significant difference.

Statistical analysis also showed significance influence ( $p < 0.005$ ) due to the adoption of both different furrow irrigation methods as well as irrigation intervals on weight of cobs per plot (Table 7). Highest weight of cobs per plot were recorded from  $AFI_{Norm}$  130.2kg per plot ( $28933 \text{ kg ha}^{-1}$ ) and 135.3kg per plot ( $30067 \text{ kg ha}^{-1}$ ) for both seasons respectively at Lelisa Dimtu Site respectively. However, the lowest weight of cobs 93kg per plot ( $20689 \text{ kg ha}^{-1}$ ) and 97 kg per plot ( $21578 \text{ kg ha}^{-1}$ ) were recorded from FP for both seasons respectively.

Table.8. Average Weight cobs (green cobs) under different irrigation treatments at Lelisa Dimtu during 2018/19 and 2019/20

Treatment	Diga ( Lelisa Dimtu)							
	Season 2018/19				Season 2019/20			
	Weight cobs per plot(kg)			Total Weight (kg/ha)	Weight cobs per plot (kg)			Total Weight (kg/ha)
small	medium	large	small		medium	large		
FP	8.7b	12.1c	72.4c	20689d	3.1bc	17.3cd	76.7c	21578d
CFI	8.3b	17.5b	77.6b	22978c	2.7c	21.3bc	83.3b	23844c
$AFI_{Norm}$	6.0d	34.1a	90.1a	28933a	7.3a	33a	95a	30067a
$AFI_{Extend}$	7.4c	12.7c	80.6b	22378c	5.0abc	13.3d	86.1b	23200c
$AFI_{Redu}$	9.5a	21.8b	81.1b	24978b	6.0ab	26b	84.4b	25867b
CV	13.4	15.2	13.8	15.8	12.4	17.6	14.8	16.8
LSD	0.4	4.6	4.9	1422	2.9	5.9	5.9	1489

**Note:** FP; Farmer Practice, CFI; Convectional Furrow Irrigation,  $AFI_{Norm}$ ; Alternate Furrow irrigation with normal irrigation Interval,  $AFI_{Extend}$ ; Alternate furrow irrigation with extended irrigation interval,  $AFI_{Redu}$ ; Alternate furrow irrigation with reduced irrigation interval, CV; Coefficient of Variance and LSD; least significant difference.

Highly significant ( $p < 0.005$ ) difference was observed on number cobs per plot due to different irrigation methods with different irrigation intervals during both the study season at Wayu Tuka (Xaxo site) (Table 8). The higher number of cobs per plot 452 (100444 per hectare) and 459 (102000 per hectare) were obtained from  $AFI_{Norm}$  and statistically superior to other irrigation method during both season. The lower number of cobs per plot 439 (97556 per hectare) and 446 (99111 per hectare) were observed from FP treatment during both season respectively. Application of Alternate furrow irrigation with normal irrigation interval (irrigation interval produced by CROPWAT Model) for maize improved number of cobs than convectional furrow irrigation and other irrigation methods. Beside this, statistical analysis showed that stand count of maize had not affected by the application of different irrigation systems with different irrigation intervals ( $p < 0.05$ ). On the other hand, statistically insignificant difference was observed between  $AFI_{norm}$  and  $AFI_{extended}$  regarding in number of cobs during both seasons (table 8).

This implies at Xaxo Site, under  $AFI_{norm}$  and  $AFI_{extended}$  treatments similar green cob yield was observed with less amount of water applied for  $AFI_{extended}$  during both seasons. When comparing CFI and  $AF_{norm}$ , the latter increased number of green cobs by approximately 1555/ha in the first and second seasons. This result shows the same trend as Abd El-Halim [15] reported Shifting irrigation practice from conventional irrigation (CFI) to alternate furrow increased corn yield to 8.9% (0.5 ton/ha).

Table.9. Average number of cobs (green cobs) under different irrigation treatments at Lega Xaxo during 2018/19 and 2019/20

Treatment	Wayu Tuka (Lega Xaxo)									
	Season 2018/19					Season 2019/20				
	Stand count	Number of cobs per plot			Total number of cobs per ha	Stand count	Number of cobs per plot			Total number of cobs per ha
small		Medium	large	small			mediu m	Large		
FP	160.7a	65.0c	132.3c	241.7c	97556c	165.7c	70.0c	138.3c	248.7c	99111c
CFI	161.3a	65.7bc	132.7c	243.3bc	98156c	166.3c	70.7bc	138.7c	250.3bc	99711c
$AFI_{Norm}$	164.7a	66.7a	136a	249.3a	100444a	169.7a	71.7a	142a	256.3a	102000a
$AFI_{Exten}$	1643.3a	66.3ab	135a	248a	99933a	1648.3ab	71.3ab	141a	255a	101489a
$AFI_{Redu}$	161.7a	66ab	133.7b	245b	98822b	166.7bc	71ab	139.7b	252b	100378b
CV	12.3	17.4	15.6	16	11.3	12.4	16.4	10.2	17.4	12.5
LSD	5.76	0.81	0.94	2.3	700	1.8	0.81	0.9	2.3	711

**Note:** FP; Farmer Practice, CFI; Convectional Furrow Irrigation,  $AFI_{Norm}$ ; Alternate Furrow irrigation with normal irrigation Interval,  $AFI_{Exten}$ ; Alternate furrow irrigation with extended irrigation interval,  $AFI_{Redu}$ ; Alternate furrow irrigation with reduced irrigation interval, CV; Coefficient of Variance and LSD; least significant difference.

The analysis of means and both season data also revealed that different irrigation methods with different irrigation interval on maize had a highly significant ( $p < 0.05$ ) influence on weight of cobs per plot (Table 9). Moreover, weight of cobs (green cob) of maize was significantly ( $p < 0.05$ ) affected by different types irrigation methods with different irrigation interval at Lega Xaxo site for both seasons. Maximum weight of cobs per plot 126 ( $28044\text{kg/ha}^{-1}$ ) and 129 ( $28711\text{kg/ha}^{-1}$ ) were observed from  $\text{AFI}_{\text{Norm}}$  treatment during both season respectively. The maximum weight of cobs obtained from  $\text{AFI}_{\text{Norm}}$  was statistically superior to both treatments which followed Alternate furrow irrigation condition. Moreover, the minimum weight of cobs per plot 89 ( $19822\text{kg/ha}^{-1}$ ) and 93 ( $20711\text{kg/ha}^{-1}$ ) were obtained from FP treatment were statistically inferior to other treatments during both seasons respectively.

Table 10. Average Weight cobs (green cobs) under different irrigation treatments at Lega Xaxo during 2018/19 and 2019/20

Wayu Tuka (Lega Xaxo)								
Season 2018/19					Season 2019/20			
Treatment	Weight cobs per plot			Total Weight (kg/ha)	Weight cobs per plot			Total Weight (kg/ha)
	small	medium	large		small	medium	large	
FP	8ab	13.2b	68d	19822d	8.8b	18.7c	65.7d	20711d
CFI	7.3ab	14.1b	78.3c	22156c	10.7ab	21bc	71.4c	22911c
$\text{AFI}_{\text{Norm}}$	7b	26.5a	92.7a	28044a	12.7a	31.2a	85.3a	28711a
$\text{AFI}_{\text{Exten}}$	7.4ab	14.53b	74.6c	21444c	10.7ab	21.1bc	68.5cd	22267c
$\text{AFI}_{\text{Redu}}$	9.5a	14.5b	84.4b	24089b	10.9ab	23.5b	78.1b	24978b
CV	13.6	14	12	10.7	15.4	13.5	10.5	12.3
LSD	2.2	3.9	4.9	1600	2.9	4.8	4.7	1200

**Note:** FP; Farmer Practice, CFI; Convectional Furrow Irrigation,  $\text{AFI}_{\text{Norm}}$ ; Alternate Furrow irrigation with normal irrigation Interval,  $\text{AFI}_{\text{Exten}}$ ; Alternate furrow irrigation with extended irrigation interval,  $\text{AFI}_{\text{Redu}}$ ; Alternate furrow irrigation with reduced irrigation interval, CV; Coefficient of Variance and LSD; least significant difference.

### Water productivity (WP)

Water productivity was significantly ( $p < 0.05$ ) influenced due to application of different irrigation method with different irrigation intervals at Diga (Lelisa Dimtu site) and Wayu Tuka (Xaxo site) for both seasons (Table 10). Results indicated that the water productivity of maize was higher under  $\text{AFI}_{\text{norm}}$  next to  $\text{AFI}_{\text{extended}}$  treatment during both seasons as compared with conventional and other treatments. Maximum water productivity values were  $3.42\text{kg/m}^3$ ,  $3.45\text{kg/m}^3$ ,  $3.55\text{kg/m}^3$  and  $3.30\text{kg/m}^3$  observed from  $\text{AFI}_{\text{extended}}$  and statistically superior to  $\text{AFI}_{\text{norm}}$  and other treatments for both seasons respectively. Statistically there was significant difference between Water productivity values of  $\text{AFI}_{\text{norm}}$  and  $\text{AFI}_{\text{extended}}$  at both locations and

seasons. However, there was no statistical difference between  $AFI_{norm}$  and  $AFI_{reduced}$  on water productivity values for both location and seasons. This implies that more amount of water was applied under  $AFI_{reduced}$  at both sites than  $AFI_{norm}$  produces similar water productivity values. The minimum water Productivity values were  $1.04\text{kg/m}^3$ ,  $1.05\text{kg/m}^3$ ,  $1.03\text{kg/m}^3$  and  $1.05\text{kg/m}^3$  s observed at both locations from FP respectively and this was statistically inferior to other treatments (Table 10). These results indicated that  $AFI_{extended}$  and  $AFI_{norm}$  were appropriate to increase WP because they allow applying less irrigation water for maize production.

The high WP values for AFI could be due to the small amount of applied water for AFI as compared with the EFI treatment. Sepaskhah and Hosseini (2008) reported similar results. In addition, Nouri and Nasab (2011) concluded that the AFI system generally increases crop yield and WP. Clearly, WP depends on total applied water. This finding agrees with results obtained by Ibrahim and Emara (2010), who reported that an adverse relationship was found between the amount of applied irrigation water and WP.

Table.11. Water Productivity of maize crop at Diga and Wayu Tuka sites of both seasons

Treatment	Diga		Wayu Tuka	
	Season 2018/19	Season 2019/20	Season 2018/19	Season 2019/20
	WP	WP	WP	WP
FP	1.04d	1.05d	1.03d	1.05d
CFI	1.60c	1.62c	1.69c	1.67c
$AFI_{Norm}$	2.84b	2.85b	2.46b	2.56b
$AFI_{Exten}$	3.42a	3.45a	3.55a	3.30a
$AFI_{Redu}$	2.30b	2.32b	2.09b	2.12b
LSD	0.6	0.6	0.6	0.5
CV	12.4	10.7	14.4	11.4

**Note:** FP; Farmer Practice, CFI; Convectional Furrow Irrigation,  $AFI_{Norm}$ ; Alternate Furrow irrigation with normal irrigation Interval,  $AFI_{Exten}$ ; Alternate furrow irrigation with extended irrigation interval,  $AFI_{Redu}$ ; Alternate furrow irrigation with reduced irrigation interval, CV; Coefficient of Variance and LSD; least significant difference.

### Conclusion and Recommendation

The effort of this study was to determine the effect of Alternate furrow irrigation with different irrigation interval on maize green cob production by comparing with farmer practice and convectional furrow irrigation. Beside this, maximum number of green cobs and green cob weight were obtained by applying Alternate furrow irrigation with normal irrigation interval throughout the growing season at both locations and during 2018/19 and 2019/20 growing seasons. Crop water productivity (WP) is highest for Alternate furrow irrigation with extended irrigation interval when comparing with Alternate furrow irrigation with normal

irrigation interval and other treatments at both study area. Higher water productivity can be obtained by stressing maize crop by extending irrigation interval under alternate furrow irrigation. However, extending irrigation interval under Alternate furrow irrigation showed yield reduction when comparing with applying Alternate furrow irrigation with normal irrigation interval.

Alternate-furrow irrigation with appropriate normal irrigation interval (irrigation interval produced by CROPWAT software) can be used as an efficient method for maize n production during dry season when production depends heavily on irrigation. It could be concluded that Alternate-furrow irrigation with normal irrigation interval can improve crop water productivity without the risk of yield reduction. Generally in all parameters alternative furrow system with full irrigation application has shown the good mean results in contrasts to other treatments under normal irrigation water quality.

Therefore, it is recommended that if the cost of available water is not high and excess water delivery to the field does not require any additional expense, then the alternate furrow irrigation with normal irrigation interval will essentially be the best choice under the conditions of the study area.

## Reference

- Aallen 1998. Water Consumption by Agricultural Plants:Water Deficits in Plant Growth. first. ed. Kozlowski T. T. New York: Academic Press.
- Abdel-Maksoud, H.H., Sanaa A. Othman, and A.Y. El-Tawil. 2002. Improving water and N-use utilization for field crops via alternate furrow irrigation technique 1-Maize crop. Mansoura University Journal of Agricultural Sciences Mansoura University 27:8761-8769.
- Awad Abd El-Halim, 2013. Impact of alternate furrow irrigation with different irrigation intervals on yield, water use efficiency, and economic return of corn. Chilean journal of agricultural research 73(2) april-june.
- Blake G R and KH Hartage . 1986. Methods of Soil Analysis: Bulck Density. 2nd ed. ed. Klute A. Madison Wisconsin USA: American society of agronomy Inc. and soil science society of America Inc. 363-375.
- Bouwer H. 1986. Methods of Soil Analysis: Intake Rate in Cylinder Infiltrometer. 2nd ed. ed. Klute A. Madison Wisconsin USA: American society of agronomy Inc. and soil science society of America Inc. 825-843.
- Debaeke P, Aboudrare A (2004) Adaptation of crop management to water-limited environments. Eur J Agron 21: 433-446.
- El-Beltagy, A.T., and A.F. Abo-Hadeed. 2008. The main pillars of the National Program for maximizing the water-use efficiency in the old land. 30 p. The Research and Development Council. Ministry of Agriculture and Land Reclamation (MOALR), Giza, Egypt (in Arabic).
- Kashiani, P., G. Saleh, M. Osman, and D. Habibi. 2011. Sweet corn yield response to alternate furrow irrigation methods under different planting densities in a semi-arid climatic condition. African Journal of Agricultural Research 6:1032-1040.

- Lambisso R (2008) Assessment of design practices and performance of small scale irrigation structures in south region.
- Mebrahtu Y (2017) Response of onion to deficit irrigation under different furrow irrigation water management techniques in raya valley, northern Ethiopia. (Doctoral dissertation, Hawassa University).
- Mintesinot B, Abdulkedir M, Mezgebu A, Mustef Y (2005) Preliminary report community based irrigation management in the Tekeze basin: Impact assessment a case study on three small-scale irrigation schemes (micro dams). A collaborative project between Mekelle University, ILRI and EARO.
- Monteith JL, Unsworth MH (1990) Radiation environment. Principles of environmental physics (2nd edn), Edward Arnold, London 36-57.
- Nasri, M., M. Khalatbari, and H.A. Farahani. 2010. The effect of alternate furrow irrigation under different nutritional element supplies on some agronomic traits and seed qualitative parameters in corn (*Zea mays* L.) *Journal of Cereals and Oilseed* 1(2):17-23.
- Nelson, D.J., and M.M. Al-Kaisi. 2011. Agronomic and economic evaluation of various furrow irrigation strategies for corn production under limited water supply. *Journal of Soil Water Conservation* 66(2):114-120.
- Oweis T, Pala M, Ryan J (1998) Stabilizing rainfed wheat yields with supplemental irrigation and nitrogen in a Mediterranean climate. *J Agron* 90: 672-681.
- Oweis T, Zhang H, Pala M (2000) Water use efficiency of rainfed and irrigated bread wheat in a Mediterranean environment. *J Agron* 92: 231-238.
- Penman HL (1948) Natural evaporation from open water, bare soil and grass. *Proc R Soc Lond A* 193: 120-145.
- Rafiee, M., and G. Shakarami. 2010. Water use efficiency of corn as affected by every other furrow irrigation and planting density. *World Applied Science Journal* 11:826-829.
- Sepaskhah, A.R., and M.H. Khajehabdollahi. 2005. Alternate furrow irrigation with different irrigation intervals for maize (*Zea mays*L.) *Plant Production Science* 8:592-600.
- Shayannejad, M., and A. Moharreri. 2009. Effect of every-other furrow irrigation on water use efficiency, starch and protein contents of potato. *Journal of Agricultural Science* 1(2):107-112.
- Sleper, D.A., S.L. Fales, and M.E. Collins, 2007. Foreword. In: *Irrigation of agricultural crops* (R.J. Lascano and R.E. Sojka, eds), 2<sup>nd</sup> edition, Agronomy Monograph no.30. ASA-CSSA-SSSA publishing, 664p.
- Ulsido MD, Alemu E (2014) Irrigation water management in small scale irrigation schemes: The case of the Ethiopian rift valley lake basin. *Environmental Research Engineering and Management* 67: 5-15.
- Webber HA. 2006. Water Use Efficiency of Common Bean and Green Gram Grown Using Alternate Furrow and Deficit Irrigation. *Agricultural Water Management* 86(3): 259–68. DOI: 10.1016/j.agwat.2006.05.012.

# Ground Water Quality Assessment and Testing for Irrigation Purpose, in irrigation potential of Eastern Hararge Zone

Jemal Nur

*Oromia Agricultural Research Institute, Fedis Agricultural Research Centre, P.o.Box, 904, Harar, Ethiopia. Corresponding Author Email: [jeminur@gmail.com](mailto:jeminur@gmail.com)*

## Abstract

*The ground water quality was conducted for different purpose in line with that irrigation water the major issue related with crop production as well as yield reduction through soil salinization. Irrigation water, whether diverted from streams or pumped from tube wells, contain appreciable quantities of harmful substances in solution those may reduce crop yield and deteriorate soil fertility. The main characteristics to assess the quality of irrigation water are Total Dissolved Solids (TDS), Sodium Absorptions Ratio (SAR), pH, Electrical Conductivity (EC) and Residual Sodium Carbonate (RSC) Permeability index (PI), Kelly's Ratio (KR) and Total Hardness. Unfortunately, in Easter part of Ethiopia the quality of surface and groundwater is not yet tested or evaluated monitored for domestic use or/and irrigation purpose even though the test result indicates salinity levels of the samples were in warning area. Hence considerable area of land is becoming unproductive in near future because of salinity or sodicity in potential area of ground water user of farmers like Haramaya and Kombolca. For sound land use and irrigation water management, it is a paramount important to know the salinity/sodicity status of soils and irrigation water quality. More over application of poor quality water for irrigation can cause soil problems such as salinity, sodicity, alkalinity, toxicity and water infiltration rate. Assessment of irrigation water quality has, therefore, been designed to include basic concepts of water quality parameters, criteria, and standards to define irrigation water quality. The result gave yellow card of their irrigation water status. Therefore the generated information every GO or NGO would work on improve knowledge and skills farmers or agricultural professionals, how to manage their irrigation practice and on practice amendment of soil already affected to use wisely and saving this resources for potential production for next generation.*

**Key words:** *Ground Water quality assessment, water quality parameters and standard Testing*

## Introduction

Water quality influences its suitability for a particular use, i.e. how well the quality fulfills the requirement of the user. Water quality deals with the physical, chemical and biological characteristics of water in relation to all other hydrological properties (Muhammad and Amir 2017). Surface and Groundwater use for irrigation, domestic and other purposes is increasing with increasing population globally and related food insecurity problems, evaluation of water quality for human consumption, agricultural and industrial activities have not been given

attention especially in developing countries like Ethiopia. A few number of literatures are available regarding the assessment of water quality data based on different irrigation indices in different areas of the world (Sarkar and Hassan, 2006; Raihan and Alam, 2008). However characterizing water quality have become important in water resources planning and development for drinking, industrial and irrigation purposes. Water quality is the basic to judge the fitness of water for its proposed application for existing conditions. The current information is required, provided by water quality monitor for optimum development and management of water for its proficient uses (Haydaret *al.*, 2009; Shakoor, 2015).

Ethiopia has 12 river basins that provide an estimated annual runoff of ~125 billion m<sup>3</sup>, with the Abbay basins (in central & northwest Ethiopia) accounting for ~45 percent of this amount (Awulachewet *al.* (2007). While much of this run-off could be used for irrigation or other purposes, Ethiopia has limited water infrastructure to use this surface water and rarely exploited its groundwater resources for agriculture. Research in this area is relatively new and initial estimates of groundwater potential vary from 2.6 to 13.5 billion m<sup>3</sup> per year (WAPCOS, 1990).

As well know recently government of the country or regional government as well as non-governmental organizations is engaged in water resource development activities both at household and community level to be used as a source of water for supplementary or complementary irrigation. However, availability of water by itself is not a guarantee for sustainable agricultural development, but its acceptability for different purposes like irrigation and domestic use is very important. Irrigation water quality problems may be caused by total mineral salts accumulation so that crops no longer produce well due to the development of sodic soils and accumulation of toxic levels of elements such as chloride, sodium and boron, these elements could make the land unproductive that incurs additional cost soil and water for leaching. At the same time nature of the soil and its quality with time is also important to sustain the required results. Naturally all soils containsome amount of soluble salt.

Currently, in Easter Oromia surface irrigation is the most predominant form of irrigation; it includes spring development, flood spreading, and rain water harvesting and pond systems. Groundwater is also developed in different parts of the zone as source of water for irrigation.

In the study area, with the introduction of water harvesting practices, groundwater and pondwater utilization for irrigation by individual farmers has increased significantly. Despite



recently increases in local and demand-driven small-scale irrigation but, environmental and ecosystem protection are prerequisites for successful irrigation development have not get attention.

So, the issue of quality of water and soil salinity is to be considered in the early stages of irrigated agricultural development and taking the corrective management measures for long-term production and productivity of irrigated land. Hence, with this background, this paper tries to assess quality of ground water from different source and suggests some techniques suitable for proper utilization of groundwater and surface water for irrigation both at household and community level

## **Materials and Methods**

### **Description of study site**

The study was conducted in Oromia Regional State, Eastern Harage Zone administration, Haramaya and Kombolcha district of selected kebeles having irrigation potential and salinity prone area. The sites were situated at  $41^{\circ}58'30''$  to  $42^{\circ}06'30''$  and  $9^{\circ}24'00''$  to  $9^{\circ}28'30''$  E latitude and N longitude Haramaya and elevation of the site was found in between 2014 to 2066 m. a. s. l. Accordingly Kombolcha was located with coordinate location  $42^{\circ}04'30''$  to  $42^{\circ}10'00''$  and  $9^{\circ}25'30''$  to  $9^{\circ}31'00''$  East latitude and North longitude of 2085 -2213 m above sea level, where the geological formation undulation and fragmented land Farming practice of the sites were both under rain-fed, and irrigation for crop production. The major crops cultivated under rain fed were sorghum, maize, some pulse crop and, dual season crop production practiced, i.e. both under rain-fed, and irrigation were some vegetables (potato, lettuce, onion. green onion and khat dominantly cultivated in the area. The common cash crop produced under irrigation in the area, were potatoes, head cabbage, leaf cabbage lettuce, small pod hot pepper, carrot, beat root, green onions (baro), very important crop following khat.

The farmers of the study area use irrigation agriculture mainly using hand-dug wells, household farm ponds. Farmers are used to grow crops three times a year, two during the dry season (September to May) by traditional closed ended border, bed type flooding, count larger furrow irrigation methods, the other during the rainy season (June September) as rain-fed cultivation. To maximize yield, farmers use both organic and inorganic fertilizer especially urea and NPS. These may contribute towards increase in the saline content or salinization process directly or indirectly in addition to uncontrolled direct flood irrigation using ground water.

## **Data sampling and analytical procedures**

### ***Sampling producers and materials***

A reconnaissance survey was done in the selected woreda of potential ground user, In view of that, areas which were using ground water for irrigation of the site. A total of 86 water samples, were collected from both woreda and from those about 28 was medium depth bore hole (BH), 14 shallow hand dug wells (HDW), 13 medium depth manual drill tube wells (TW) and 31 stored water at temporary ponds water in the area. Generally parameter for determination of water quality assessment for water samples categorized as on spot parameters which were from stored or temporary ponded and at pumping of water, laboratory analysis and other calculated parameters. The samples were collected according to specified distance of well from each point from selected district. Materials required for the study are sampling bottle or container, portable pocket size pH meter RH and temperature measuring portable electrical conductivity (EC) meter at field level, depth water level measuring devices or stick meter measuring tape,

### ***Field work procedure***

During field work on spot data like, Primary data: Well depth (m), tem ( $^{\circ}\text{C}$ ), water pH, EC, color, odor, well type, storage type, geographic locations (Alt., Lat., and Long altitude and were recorded using total station with association of GPS to locate local bench marks of individual sample. In order to assess water quality of the study area, all groundwater samples were collected to cover the entire study area and the map is presented in (Fig. 1). Sampling was carried out using pre-cleaned plastic bottles, which were rinsed three times with sample water prior to sample collection. Before analysis of groundwater, the instruments were calibrated in accordance with the manufacturer's recommendations for on spot data collection. For laboratory analysis was accomplished at Haramaya University laboratory for relevant parameters used to evaluate groundwater study area. The parameters include pH, Temperature Electrical Conductivity (EC) and were measured by conductivity digital multimeter (AD 3000 EC/TDS/Temperature Bench Meter) on field and laboratory. Sodium ( $\text{Na}^+$ ) and potassium ( $\text{K}^+$ ) were measured by flame photometer. Calcium and magnesium were determined with standard solution titrimetrically. Carbonate and bicarbonate were estimated by titration with  $\text{H}_2\text{SO}_4$ , Chloride by titrating against standard silver nitrate ( $\text{AgNO}_3$ ) solution. The colorimetric analysis of sulphate, nitrate and fluoride was done by spectro-photometer. Measurements were done in triplicate to ensure reliability and good quality control. However

Sodium Percentage, Sodium Adsorption Ratio (SAR), Residual Sodium Carbonate (RSC), Permeability index (PI), Kelly's Ratio (KR) and Total Hardness were computed, using the standard formulae:

### ***Water Quality Indices***

**Electrical Conductivity (EC):** Conductivity is the measure of capacity of a substance to conduct the electric current. Most of the salts in water are present in their ionic forms and capable of conducting current and conductivity is a good indicator to assess groundwater quality. Electrical conductivity is an indication of the concentration of total dissolved solids and major ions in a given water body.

**pH:** The pH of a solution is defined as the negative logarithm of the hydrogen ion activity,  $\text{pH} = -\log(\text{H}^+)$ . The range of pH is from 0 (maximum acidic) to 14 (maximum basic); pH of a neutral solution is 7. All geochemical reactions are affected by pH. Surface waters become acidic when additions of acid exceed the buffering capacity of the carbonate system. The pH is the concentration of hydrogen ions ( $\text{H}^+$ ) and hydroxyl ions ( $\text{OH}^-$ ) in the water. It is used to determine the acidic, basic or neutral behaviors of water. The electrical conductivity of water also affects the plant growth. The measurement of EC at 25°C temperature is considered as reference.

**Total Dissolved Solids (TDS):** The salinity behavior of water is indicated by total dissolved solids (TDS). TDS contain the anions (negatively charged ions) and cations (+ve charged ions). Total dissolved solids change the color and properties of water. The relationship between total dissolved solids and EC is: The EC of the water ( $\text{EC}_w$ ) was measured by inserting the electrical conductivity cell directly in the solution above a 1:1 soil: water paste. This is different from measuring the apparent EC of the soil paste where the electrodes are embedded in the wall of the container (Rhoades *et al.* 1999). Many recommendations are based on the salt content in a soil sample. Different types of salts present in the soil and the various analyses of the samples complicate the direct conversion of EC into (TDS), and vice versa. Some salts have a higher EC compared to other salts. Conversion of  $\text{EC}_w$  to TDS was determined based on of salinity level. According to (Lazarova *et al.*, 2004a) the composition of water is expressed as:

$$\text{TDS (mg/L)} = 640 * \text{EC}_w \text{ (ds/m)} \text{ when } \text{EC}_w < 5 \text{ ds/m}$$

$$\text{TDS (mg/L)} = 800 * \text{EC}_w \text{ (ds/m)} \text{ when } \text{EC}_w > 5 \text{ ds/m}$$

Color and Oder: The water color is an important indicator to define water and pollutants source. Water color represents the type of solid material present in it. Transparent water with low level of dissolved solids has blue color while yellow or brown color is due to the dissolved organic matter. The apparent blue color of water bodies is due to selective absorption and scattering of light spectrum. Some algae produce reddish or deep yellow waters. Similarly, the water rich in phytoplankton and other algae appears as green. True color could be measured by filtering the water after removing all suspended material (CWT, 2004).

SolubleSodium percentage (SSP): This term is also referred to as soluble sodium percentage or percent sodium. It is a computed by the following equation Wicox (1955).

$$SSP(Na \%) = \frac{Na^+ + K^+}{Ca^{2+} + Mg^{2+} + Na^+ + K^+} \times 100$$

Where: the concentrations are in meq l<sup>-1</sup>.

Sodium Adsorption Ratio (SAR): Sodium adsorption ratio (SAR) is the effective factor or parameter used for ascertaining the suitability of groundwater for irrigation purposes. Sodium Adsorption Ratio (SAR) estimated or calculated according to (Richards (1954)) equation:

$$SAR = \frac{Na^+}{\sqrt{\left(\frac{Ca^{2+}}{2} + \frac{Mg^{2+}}{2}\right)}}$$

Where Na<sup>+</sup>, Ca<sup>2+</sup>, and Mg<sup>2+</sup> are concentrations of sodium, calcium, and magnesium in meq l<sup>-1</sup>), respectively.

Residual Sodium Carbonate (RSC): For agricultural purposes, residual sodium carbonate (RSC) is usually used to ascertain the dangerous effect of carbonate and bicarbonate on the quality of water. (Bhatet.al, 2018)cited Naseemet al. reported that pH, EC and SAR of the irrigation water are significantly influenced by RSC. The continuous usage of water having high RSC will cause burning of plant leaves and reduces the yield of crops [Ramesh ,Elango 2012: Toumiet.al. 2015].

The Residual Sodium Bicarbonate (RSBC) was calculated according to Gupta and Gupta (1987)

$$\text{RSC (meq l}^{-1}\text{)} = (\text{HCO}_3^- - \text{Ca}^{2+})$$

Where, RSBC and the concentration of the constituents are expressed in meq l<sup>-1</sup>

The land irrigated with water having high RSC assumes high pH; makes the soil infertile because of deposition of sodium carbonate as is recognized from the black color of the soil (Purushothaman *et al.*, 2012)

Magnesium Adsorption Ratio (MAR): Groundwater alkaline earth metals are in state of equilibrium. Since, magnesium is an essential nutrient for plant growth and its deficiency causes yellowing and reduction in growth and yield of crops. The concentration of magnesium in water plays a pivotal role in deciding the quality of water for irrigation purposes, therefore, agricultural use (Sappa *et al.* 2014). Magnesium percentage of water for irrigation is calculated by the formula (Szabolcs *et al.* 1964).

$$\text{MAR} = \frac{\text{Mg}^{2+}}{\text{Ca}^{2+} + \text{Mg}^{2+}} * 100$$

Permeability Index (PI): The long-term use of irrigation water had a profound effect on soil permeability as it is influenced by total dissolved salts, sodium content and bicarbonate content. Therefore, to integrate these three terms, Doneen formulates empirically devised an equation referred to as Permeability Index (PI)' after carrying a series of investigations for which he used enormous number of irrigation water samples of variable ionic relationships and concentration (Doneen, 1964).

$$\text{PI} = \frac{\text{Na}^+ + \sqrt{\text{HCO}_3^-}}{\text{Ca}^{2+} + \text{Mg}^{2+} + \text{Na}^+} * 100$$

Permeability index is a crucial parameter for assessing the suitability of irrigation water. From the ecological viewpoint, in combination with subsurface structural features high permeability index would facilitate extensive contamination of groundwater (Al-Tabbal and Al-Zboon, 2012)

Kelly's ratio: Kelly's Ratio was formulated by Kelly (1951) and is computed by dividing sodium ion concentration versus calcium and magnesium ion concentrations [86] where, concentrations of all ions were expressed in meq l<sup>-1</sup>

$$KR = \frac{Na^+}{Ca^+ + Mg^{2+}}$$

Hardness: Determination of water hardness is a utilitarian test to evaluate quality of water for domestic, agricultural and industrial uses (Sappa, 2014). The hardness of water is generally caused by calcium and magnesium. However, total hardness of water can be classified into two types, i.e., temporary and permanent hardness. The total hardness (as CaCO<sub>3</sub>) of water samples can be calculated using the following equation

$$HT = 2.497 Ca^{2+} + 4.115 Mg^{2+}$$

Chloride has high solubility in water; chlorine exists as chloride ion and is the predominant natural form of chlorine (Al Obaidy *et al.*, 2014). Chloride is considered as the most common toxic ion in irrigation water. Since, chloride is not adsorbed by the soil colloids; therefore, it travels easily with soil water, is absorbed by the crop, moves into the transpiration stream, and accumulates in the leaves.

*Nitrate*: During recent years, the pollution of groundwater by nitrates has been ascertained enormously across the globe Nas and Berkta (2006). The concentration of nitrate greater than 45 mg l<sup>-1</sup> causes a disease in humans called as methemoglobinemia or blue baby syndrome Durfe and, Baker (1964).

### **Data analysis**

The data generated from field and laboratory subjected to descriptive statistics. All data was arranged, coded and analyzed using SPSS software version 20. Analysis of simple was used to compare the physical and chemical properties of irrigation water between and within soil mapping units.

## **Results and Discussion**

### **On spot data acquired at Haramay and Kombolcha Woreda**

The minimum and maximum well depth of Haramay woreda was observed as 12 m and 35m, 15 m and 33m and 2m and 10 m for HFK, HXK and HTGK and HTG respectively. Accordingly the well type found as in the area were, bore hole, tube well (manual drilling) and shallow hand dug. From those of the dominant type were bore hole (BH) which covers 54.3 % of total sample and tube well (manual drilling) was followed for HFK and HXK, Whereas at HTG kebele totally HDWs with shallow depth were the observed.

Farmer's practice ground water harvesting by preparing temporary storage behind their wells for irrigating fields. This temporary storage was different line material. For minimizing linkage or loss through seepage or Deep-percolation, some of them were line with geo-membrane, and plastic (shara), and permanently unlined pond was also observed for hand dug shallow well for direct pumping beside irrigation purpose some farmers were practicing fishing activity on their temporary line storage pond in farm yard. The physical appearance of during sampling water at storage pond and at pumping time have the same color and odor i.e. it at normal levels and the temperature at both time is recorded at room temperature range. The mean minimum and max temperature recorded at HFK shown that 19.45<sup>0</sup>C and 26.65<sup>0</sup>C at storage and pumping time respectively. Similarly at HXK 17.1<sup>0</sup>C and 21<sup>0</sup>C was minimum and max temperature recorded at storage and pumping time respectively. Even though, it was at room temperature range, the reading or result indicated that samples at pumping time collected from pumping out shows little bit higher than that of sample collected from stored ones. This may be due to heat found inside the earth or less air circulation at lower well depth.

### ***Kombolcha Woreda***

The minimum and maximum well depth of Kombolcha woreda was observed as 7m and 18 m, 2 m and 24 m and 2 m and 10 m for Kombolcha Bilisuma (KBK) and Egu (KEK) Kebeles respectively. Accordingly type of well found as in the area were, Bore hole, tube well (manual drilling) and shallow hand dug wells. From those three type of the dominant type were bore hole (BH) which covers 45 % of total sample and 30% of shallow depth HDW followed by 25 % tube well (manual drilling) was observed at KBK) and (KEK). The temporary storage facility observed of line with geo-membrane, plastic (shara) and unlined. In addition this the physical appearance of water at storage and sample water collected at pumping time have the same color and odor i.e. it at normal levels and the temperature at both site was recorded at room temperature range. The mean minimum and max temperature recorded from KBK shown that 21.3<sup>0</sup>C and 24.8<sup>0</sup>C at respectively. Similarly at KEK 20.6<sup>0</sup>C and 27.6<sup>0</sup>C was recorded as minimum and max temperature respectively.

### **Laboratory parameters**

#### ***Haramaya laboratory parameters***

Electrical Conductivity (EC) and pH: The pH of the water samples could measure both in the field and in the laboratory using digital pH meter. From the same sample (with the same

method) used for SAR analysis, the pH data was generated. The result of the analysis indicates that the pH of the Haramaya is slightly saline (7.3) or alkaline 8.27 recorded at HTGk, whereas at Kombolcha nearly neutral 6.93 to slightly alkaline 7.54 at Bilisuma kebele (Table 3). pH highly affects the efficiency of coagulation and flocculation process (Kahlow *et al.*, 2006). Similarly Electric conductivity (EC) of the water samples have been done like the pH analysis (Richards, 1954). The values of EC obtained from the analysis at room temperature needs to be corrected to 25°C. By doing so, the laboratory result showed that the EC of the water is classified as highest 19.70 (dS/m) recorded at HTGK and the lowest 1.07 (dS/m) at Haramaya (Table 1). However the lab result of Kombolcha reveals the water quality was under normal range (Table 3) as outlined by different researchers (Biswas, 1998; FAO, 1985b; Wesstcott and Ayers, 1985). Moreover, the total dissolved solids were found at slight to medium range at both study area (Table 2 and 4). In contrast Lucia Bortolini *et al* 2018; cited different authors EC irrigation Water Quality Tool Threshold (IWQT) and their quality thresholds <0.70 was adequate for Irrigation, 0.70–6.50 falls warning and > 6.5 extreme restriction. Hence, the finding reveals almost all falls under the range of warning for Haramaya samples, but Kombolchas' was better when compared with this standard.

According to Gaurav *et al* (2017). Plant height decreased with increasing salinity (EC of water from 0 to EC-2, EC- 4, EC-6 and EC- 8. Their find explains, plant height under drip irrigation was greater than plant height under furrow irrigation at all levels of salinity. Number of tubers per plant, weight of tubers and tuber yield decreased with increasing salinity of irrigation water. Salinity reduces the plants' water uptake, increasing the osmotic potential and the force to absorb water, decreasing the plants' growth rate, photosynthesis rate, and stomata conductance Kiremit, Arslan, 2016.

Chloride and Nitrate: In the present study, 100% samples were found highly suitable at both study area which ranges, whereas Nitrate concentrations in the groundwater samples varied from 0.54 to 95.18 mg l<sup>-1</sup> with the average of 33.01 mg l<sup>-1</sup> was recorded at Haramaya district which shows at sever status according to sawyer and McCarty (1967) cited by Mohammad *et al.*, 2016 (Table 2). Accordingly lab result of Kombolcha indicated as 1.46 to 18.64 mg l<sup>-1</sup> with average of 10.85 mg l<sup>-1</sup>, which was moderate range.

The pollution of groundwater by nitrates has been ascertained enormously across the world during recent years (Nas and Berkta, 2006). According to (Jalali, 2005) finding the possible



origin of nitrate in agricultural areas include fertilizer, animal waste and mineralization of soil organic N (in plant residues, bacterial biomass and soil constituents). Due to intensive agriculture, large amounts of N fertilizers commonly urea, nitrate or ammonium compounds are applied which result in higher concentration of nitrate in the areas of intensive arable production. Ali, 2010 outlined that Excessive accumulation of chloride can cause plant injury, leaf burn, or drying of leaf tissue. In case of sprinkler irrigation, chloride toxicity can occur by direct leaf absorption. Ghanem, *et al.* 2009 reported that Na and Cl are the most common related to the salinity damages because they can be easily accumulated in plants, where they interfere with physiological, growth, and enzymatic processes.

Carbonates and Bicarbonates ( $\text{CO}_3^{2-}$  and  $\text{HCO}_3^-$ ) hazard of irrigation water: In water having a high concentration of bicarbonate, there is a tendency for calcium and magnesium to precipitate. When this happens, there is a reduction in the concentration of calcium and magnesium and a relative increase in sodium. Accordingly, the results reveal that the bicarbonate concentration at lower peak and medium peak river flow were found in the same and trace amount. Likewise, bicarbonate ranges from 1.0 to 3.20 meq  $\text{l}^{-1}$  with average of 1.58 meq  $\text{l}^{-1}$  at Haramaya district of selected. Whereas at Kombolchawasthe lowest 0.40 meq  $\text{l}^{-1}$  and the highest of 0.88 meq  $\text{l}^{-1}$  and the average 0.62 meq  $\text{l}^{-1}$ . The bicarbonate ion (hydrogenated-carbonate ion) is an anion with a negative charge and is the conjugate acid of carbonate. The weathering of rocks contributes to bicarbonate content in water as mostly these are soluble in water and their concentration in water depends on pH of water. It is a principal alkaline constituent in almost all water sources, therefore, influences hardness and alkalinity of water (Muhammad and Aamir 2017). According to Latha *et al.*, 2002 report continuous use of waters having residual sodium carbonate of more than 2.5 meq/L leads to salt build up which may hinder air and water movement by clogging the soil pores. This leads to the degradation of the physical condition of soil. Management quality indicators may determine the need to resort to modifications of irrigation and/or require particular irrigation water treatments (e.g., use of filters, sedimentation tanks, etc.)

*Calcium, Sodium and Magnesium* levels: Calcium is naturally present in water. Calcium is a determinant of water hardness, because it can be found in water as  $\text{Ca}^{++}$  ions. Calcium content in the groundwater varies from 66.12 to 279.60 mg  $\text{l}^{-1}$  min and max respectively and mean of 110.80 mg  $\text{l}^{-1}$  at Haramaya. However,  $\text{Ca}^{++}$  result of Kombolcha ranges from 58.8 to 96.7 mg  $\text{l}^{-1}$  and the mean 77.5 mg  $\text{l}^{-1}$ . Similarly the average laboratory result for Sodium and

Magnesiums 104.34 and 146.23 mg l<sup>-1</sup> were Haramaya samples and at Kombolcha 177.7 and 143.6 mg l<sup>-1</sup> Sodium and Magnesium respectively Except Na<sup>+</sup> the average lab result obtained GW samples from Haramaya and Kombolcha were all of samples were within permissible range permissible limit which was agreed with (FAO, 1985). However the mean of lab result of Na<sup>+</sup> at both locations were reached out of range of irrigation water (FAO, 1985).

Table 1. Haramaya mixed samples of laboratory result

Sample Code	pH	EC (ds m <sup>-1</sup> )	Cl <sup>-</sup> (mg l <sup>-1</sup> )	NO <sup>3-</sup> (mg l <sup>-1</sup> )	HCO <sub>3</sub> <sup>-</sup> (meq l <sup>-1</sup> )	Mg <sup>2+</sup> (mg l <sup>-1</sup> )	K <sup>+</sup> (mg l <sup>-1</sup> )	Na <sup>+</sup> (mg l <sup>-1</sup> )	Ca <sup>2+</sup> (mg l <sup>-1</sup> )
<b>Haramaya Finkle Kebele (HFK)</b>									
HFK5,13,&,14	7.8	1.29	7.44	7.14	1.04	78.50	5.59	32.43	66.12
HFK15-R	7.3	1.44	6.91	54.82	1.20	78.00	3.77	36.33	81.63
HFK10-R	7.6	2.30	11.17	57.54	1.40	89.50	14.20	53.89	148.60
HFK-R (1&4)	7.5	1.44	9.93	53.57	1.48	53.50	4.44	227.50	77.55
HFK3,7-R	7.5	1.30	7.09	23.04	1.40	73.50	2.81	34.38	80.41
HFK9,6-R	7.5	1.24	5.49	19.11	1.20	78.50	4.92	34.38	85.31
HFK12-R (2&12)	7.4	1.96	10.10	23.61	1.86	153.00	2.23	38.28	111.00
HFK11,8-R	7.5	1.43	8.86	9.64	1.06	67.50	1.94	28.52	105.70
<b>Haramaya Xinke Kebele (HXK)</b>									
HXK1,7-R	7.78	1.396	10.99	36.61	1.08	116.50	3.39	22.67	<b>106.1</b>
HXK9,2-R	7.55	1.460	6.0265	48.75	1.50	102.50	1.66	22.67	<b>92.24</b>
HXK3-R	7.56	1.560	7.4445	65.71	1.56	89.00	1.56	28.52	<b>113.9</b>
HXK4-R	7.98	1.450	6.0265	49.11	1.44	87.00	1.46	28.52	<b>106.1</b>
HXK5-R	7.96	1.409	7.2673	65.89	1.28	75.50	1.27	18.77	<b>86.53</b>
HXK6-R	7.53	1.487	7.09	95.18	1.60	79.00	1.94	24.62	<b>99.18</b>
HXK8-R	7.88	1.452	8.8625	64.82	1.36	105.50	3.58	30.48	<b>143.7</b>
HXK10-R	7.91	1.072	5.4948	24.64	1.06	108.00	1.37	20.72	<b>79.18</b>
<b>Haramaya Tuji Gebisa Kebele (HTGK)</b>									
HTGK1-R	7.89	8.40	62.04	3.04	2.00	321.50	1.46	293.90	75.92
HTGK2-R	7.74	7.61	70.90	12.43	2.00	306.00	1.66	204.10	106.50
HTGK3-R	7.49	1.45	9.93	22.68	1.72	105.00	1.94	194.40	106.10
HTGK4-R	7.72	1.35	5.32	20.54	1.60	119.00	3.00	26.57	94.69
HTGK5	7.91	10.04	88.63	28.93	1.50	309.50	5.31	<b>233.40</b>	140.00
HTGK6-R	7.71	1.309	6.03	22.68	1.22	124.00	5.88	120.20	94.69
HTGK-7	7.74	1.28	5.49	31.32	1.38	115.00	2.62	26.57	100.80
HTGK8	7.89	5.20	3.72	8.39	3.20	302.00	5.02	137.80	106.50
HTGK10-R	7.72	3.08	10.99	8.50	2.80	200.00	6.07	145.60	68.57
HTGK9-R	8.27	19.70	74.45	0.54	1.00	352.00	1.08	418.80	279.60

NB: Titration of definite quantity of water against a standard acid using phenolphthalein & Methyl orange as indicators. Firstly phenolphthalein is added as an indicator. On adding the standard acid drop – wise, the pink colour disappears when all the carbonate in the sample water are converted to bicarbonates. At this stage methyl orange is added as an indicator. Now the colour of the sample water is yellow. Titrate further against the same standard acid. Colour changes to orange when the end – point is reached.

TDS (mg l<sup>-1</sup>): it is the measure of the amount of material dissolved in water including carbonate, chloride, bicarbonate, phosphate, sulfate, nitrate, sodium, calcium, magnesium,

organic ions etc (Kahlownet *et al.*, 2006).The TDS value of the study area ranges from 686.1 to 15760.0 mg l<sup>-1</sup>with average of 2777.7 mg l<sup>-1</sup>at Haramaya, accordingly at Kombolcha the TDS of GW was estimated at min of 197.10 and max as 483.2 (mg l<sup>-1</sup>). The average results were generally greater than 2500 mg l<sup>-1</sup>and can be classified as slightly saline irrigation water according to Robinoveet *al.* (1958) for both locations.

Table 2.HaramayaSummarized result of estimate parameters

Sample code	TDS (mg l <sup>-1</sup> )	SAR	SSP%	RSCB	MAR	PI	KI	HT
<b>HaramayaFinkeleKebele (HFK)</b>								
HFK 5,13,&,14	823.0	0.636	13.63	-2.26	66.5	21.6	0.143	35.153
HFK15-R	921.0	0.687	13.69	-2.87	61.5	22	0.149	36.914
HFK10-R	1472.0	0.859	15.40	-6.01	50.2	20.5	0.158	49.197
HFK (1&4) -R	921.0	4.848	54.58	-2.39	53.5	61	1.188	28.004
HFK 3,7-R	830.7	0.664	13.39	-2.61	60.4	23	0.147	35.219
HFK 9,6-R	793.6	0.643	13.05	-3.05	60.6	21.1	0.138	37.543
HFK12-R (2&12)	1253.1	0.550	8.60	-3.68	69.7	15.2	0.091	66.290
HFK11,8-R	915.2	0.531	10.58	-4.21	51.6	18.7	0.114	36.311
<b>HaramayaXinkeKebele (HXK)</b>								
HXK6-R	951.68	0.446	8.86	-3.35	57.10	18.5	0.093	39.44
HXK3-R	998.40	0.485	8.90	-4.12	56.63	17.4	0.095	44.70
HXK8-R	929.28	0.469	8.16	-5.81	55.09	14.4	0.083	54.07
HXK4-R	928.00	0.495	9.24	-3.85	57.81	17.7	0.099	43.05
HXK5-R	901.76	0.354	7.41	-3.04	59.31	17	0.077	36.67
HXK9,2-R	934.40	0.385	7.26	-3.10	64.99	15.6	0.075	46.64
HXK10-R	686.08	0.354	6.74	-2.89	69.50	13.9	0.070	46.90
HXK1,7-R	893.44	0.360	6.67	-4.21	64.72	12.7	0.066	53.16
<b>HaramayaTujiGebisaKebele (HTGK)</b>								
HTGK1-R	6720	3.27	29.53	-1.79	87.62	32.7	0.418	119.70
HTGK10-R	1971.2	2.00	24.41	-0.62	82.97	30.3	0.315	77.12
HTGK9-R	15760	3.91	29.65	-12.95	67.78	31.2	0.421	155.53
HTGK5	8032	2.51	23.88	-5.48	78.70	26.5	0.310	123.57
HTGK2-R	6088	2.26	22.44	-3.31	82.76	25.9	0.288	118.20
HTGK3-R	927.36	3.19	37.71	-3.57	62.31	43.4	0.602	49.22
HTGK-7	819.2	0.43	7.72	-3.65	65.59	14.8	0.079	51.99
HTGK4-R	860.8	0.43	7.76	-3.12	67.74	15.3	0.079	52.60
HTGK8	4160	1.53	16.72	-2.11	82.57	21.3	0.197	116.82
HTGK6-R	837.76	2.07	29.75	-1.14	81.40	35.3	0.412	48.42

The density of the water, can be harmful due to increase in TDS concentrations, determined the flow of water into and out of an organism's cells. Moreover, the high concentrations of TDS may also reduce water clarity, contribute to a decrease in photosynthesis, combine with toxic compounds and heavy metals, and lead to an increase in water temperature (Kahlownet *et al.*, 2006).Weathering or dissolution of soil and rocks generates ions in water (Singh *et al.*

2013). Modi 2000 reported that after evaporation of water, accumulation of salt at the root zone makes obstacle and plants are not capable of sucking water from soil resulting in moisture stress.

SAR (Sodium absorption ratio): Sodium adsorption ratio (SAR) is the effective factor or parameter used for ascertaining the suitability of groundwater for irrigation purposes. It is the proportion of sodium to calcium and magnesium, which affect the availability of the water to the crop (Obiefuna and Sheriff, 2011). The sodium adsorption ratio of groundwater calculated in the study area were 1.99 to 3.92 with average of 2.73 at Kombolcha. Whereas at Haramaya 0.35 to 4.85 with average 1.41. The result reveal mean of SAR at Kombolcha higher than Haramaya.

According standard the amount of SAR irrigation water the average of calculated result falls where it was calculated from  $\text{meq l}^{-1}$  in an excellent range which was ( $\text{SAR} < 10$ ) FAO 2013. In contrast, SAR under EC, ranges from 0.5 to 1.0  $\text{ds m}^{-1}$  if it reach/falls 3 to 6 water quality moderate range according to Ali (2010). Accordingly the result observed from Kombolcha kebeles were 30.8%, 61.5% 7.7% Moderate, good and excellent class respectively. Similarly from collected sample especial HTGK of Haramaya was 30%, 40% and 30% moderate, good and excellent class respectively. SAR can indicate the degree to which irrigation water tends to enter into cation-exchange reactions in soil. Sodium replacing adsorbed calcium and magnesium is a hazard as it causes damage to the soil structure and the soil becomes compact and impervious (Raju, 2007).

Table 3. Kombolchaworeda mixed samples of laboratory result

Sample Code	pH	EC ( $\text{ds m}^{-1}$ )	Cl <sup>-</sup> ( $\text{mg l}^{-1}$ )	NO <sup>3-</sup> ( $\text{mg l}^{-1}$ )	HCO <sub>3</sub> <sup>-</sup> ( $\text{meq l}^{-1}$ )	Mg <sup>2+</sup> ( $\text{mg l}^{-1}$ )	K <sup>+</sup> ( $\text{mg l}^{-1}$ )	Na <sup>+</sup> ( $\text{mg l}^{-1}$ )	Ca <sup>2+</sup> ( $\text{mg l}^{-1}$ )
<b>Kombolcha Bilisumakebele (KBK)</b>									
KBK9R	7.27	2.32	15.6	8.857	0.76	211.7	1.46	210.0	79.18
KBK5R	7.09	0.79	18.43	14	0.84	138.8	1.75	126.1	73.47
KBK1&4	7.02	0.4	14.18	8.214	0.4	84.63	2.62	184.6	78.78
KBK8&10	7.10	1.83	14.18	18.64	0.8	186.6	2.62	180.7	96.73
KBK3&2	7.03	0.43	14.18	9.071	0.56	124	3.19	204.1	92.24
KBK6	7.54	1.22	19.85	14.21	0.88	189.1	3.39	284.1	82.45
<b>Kombolcha Egukebele (KEK)</b>									
KEK9&10	7.2	3.7	19.852	1.464	0.4	193	4.92	182.7	77.96
KEK7&4	7.4	0.54	12.762	17.79	0.64	124	5.11	143.6	58.78
KEK1&8	7.53	0.755	21.27	9.214	0.48	142.3	5.88	211.9	80
KEK5R	7.01	0.562	14.18	11.14	0.56	63.45	3	122.2	71.02

KEK2R	7.22	0.466	14.18	12.21	0.68	220.6	5.59	157.3	70.2
KEK6RP	7.04	0.308	8.508	8.643	0.52	60.99	1.66	106.6	68.16
KEK3RP	6.93	0.402	12.762	9.143	0.56	133.9	2.52	161.2	78.37

Soluble Sodium Percentage (SSP): Sodium percent is an important factor for studying sodium hazard. It is also used for adjudging the quality of water for agricultural purposes. High percentage sodium water for irrigation purpose may stunt the plant growth and reduces soil permeability (Joshi *et al.*, 2009). The soluble sodium percentage values of groundwater sample collected in the Haramayakebeles were ranges in between 6.7% to 54.6% with average of 17.8%. Whereas the result of Kombolchakebeles were 24.19 to 42.43 with the average of 33.14%. According to (Ayers and Westcot, 1985; Eaton, 1950) finding the result revealed that collected samples falls in different ranges or class i.e. The analysis result of Haramaya 69.2%, 26.9% and 3.9% excellent, good and fair respectively, however, the result of Kombolcha was 92.3% and 7.7% good and fair.

Magnesium Adsorption Ratio (MAR): Magnesium content of water is considered as one of the most important qualitative criteria in determining the quality of water for irrigation. Generally, calcium and magnesium maintain a state of equilibrium in most waters. More magnesium in water will adversely affect crop yields as the soils become more saline (Joshi *et al.*, 2009). The values of The MAR of groundwater samples calculated from lab result varies from 59.9 to 84.0% and with average values of 73.7% at Kombolchakebeles whereas at Haramaya found in between 50.20 to 87.62% with average of 66.3% (Table 2 and 3). Indicating that they are above the acceptable limit of 50% (Ayers and Westcot, 1985). Excess concentration of magnesium in groundwater affects the soil quality by converting it into alkaline and decreases the crop yield (Gautam *et al.* 2015). According to Narsimha *et al.* 2013) report excess amount of  $Mg^{2+}$  ions in waters damage the soil quality which causes low crop production

Table 4. Kombolcha summarized result of estimate parameters

Sample Code	TDS ( $mg\ l^{-1}$ )	SAR	SSP%	RSCB	MAR	PI	KI	HT
Kombolcha Bilisumakebele (KBK)								
KBK <sub>9</sub> R	1484.8	2.78	29.81	-3.19	81.71	33	0.42	82.46
KBK <sub>5</sub> R	506.88	1.99	26.63	-2.82	75.94	31	0.36	56.75
KBK <sub>1&amp;4</sub>	254.72	3.43	42.43	-3.53	64.22	46	0.73	38.83
KBK <sub>8&amp;10</sub>	1173.1	2.46	28.00	-4.02	76.32	31	0.39	76.03
KBK <sub>3&amp;2</sub>	273.28	3.25	37.49	-4.04	69.19	40	0.59	54.01
KBK <sub>6</sub>	783.36	3.92	38.50	-3.23	79.30	41	0.62	75.11
Kombolcha Egukebele (KEK)								

KEK <sub>9&amp;10</sub>	279.7	2.51	28.78	-3.49	80.53	30.7	0.398	75.89
KEK <sub>7&amp;4</sub>	345.6	2.42	32.46	-2.29	77.90	36.1	0.471	49.84
KEK <sub>1&amp;8</sub>	483.2	3.27	37.14	-3.51	74.82	39.5	0.581	58.76
KEK <sub>5-R</sub>	359.7	2.53	37.91	-2.98	59.88	42.9	0.602	30.60
KEK <sub>2-R</sub>	298.2	2.07	24.19	-2.82	84.00	26.7	0.313	84.39
KEK <sub>6-R&amp;P</sub>	197.1	2.25	35.54	-2.88	59.92	40.8	0.546	29.40
KEK <sub>3-R&amp;P</sub>	257.3	2.55	31.95	-3.35	74.06	35.1	0.465	55.68

Permeability index (PI): The permeability index (PI) is an indicator to study the suitability of water for irrigation purpose. According to Doneen (1964), PI can be categorized in three classes: class I (>75%, suitable), class II (25–75%, good) and class III (<25%, unsuitable). Water under class I and class II is recommended for irrigation. The PI values computed for Kombolcha falls in good range. Whereas estimated PI of total sample collected from Haramayakebeles shows that 73.1% unsuitable for irrigation and 26.9% found in good range.

Kellys Ratio (KR): The Kellys Ratio (KR) values of the Haramayakebeles were found in between 0.071 to 1.19 with average 0.26. Similarly 0.31, 0.73 and 0.50 of minimum, maximum and average KR respectively were recorded at Kombolchakebeles (Table 3). The results indicate that most of the KR for the groundwater samples fall within the permissible limit of 1.0 and, it were considered suitable for irrigation purpose according to (Sundary, 2009) classification.

Total hardness (TH): The result computed from Kombolchakebeles were values recorded 29.40 and 84.39 mg l<sup>-1</sup> minimum and maximum respectively (Table 3). However at Haramaya minimum and maximum TH value recorded as 28.0 and 155.5 mg l<sup>-1</sup> respectively (Table 2). The total hardness is the indicator of the capacity of water to precipitate soap (Ahmad and Faizan 2016). According to (U.S. EPA, 1986) classification TH is usually as soft (0–60 mg l<sup>-1</sup>), moderately hard (60–120 mg/l), hard (120–180 mg l<sup>-1</sup>) and very hard (>180 mg l<sup>-1</sup>). According to this classification the result of GW sample collected from the study area were 73.1% 11.5% and 15.4% falls under soft, moderately and hard water respectively at Haramayakebele. Similarly at Kombolcha 61.5% and 38.5% was computed and classified as soft and moderately.

## Conclusion and Recommendation

The finding reveals that irrigation water quality of Haramayakebeles in terms of basic salinity (TDS/ECw, SAR/Na, MAR/Mg, and SSP%, PI, TH, in falls under the range of warning or unsuitable range. Similarly in case of, Kombolcha the same result was occurred, however it was little better when compared with Haramaya.

Hence to minimize risk of water salinity which resulted on soil salinity as well as sodicity the following recommendations were drawn:

- Shifting traditional irrigation like direct flooding, border, larger furrow) irrigation method to modern irrigation method (drip, bubble and SS sprinklers...)
- Training farmers on irrigation water management or water saving furrow irrigation methods (FFI, AFI and controlled CFI, and
- Irrigation scheduling by applying why? When?, how much? to irrigate through consideration of soil, crop... factors (environmental factors)
- For more sever area crop selection and field management or modifying seed placement like on furrow/ridge planting
- Soil amendment traditionally through organic fertilizers (compost, cow dung, farmyard manure....
- For further recommendation with similar point and location soil profile data for soil salinity and sodicity test have to been necessary done

## Acknowledgement

My great thanks goes to the Oromia Agricultural Research Institute (OARI) and Fedis Agricultural research center for granting me a study leave with pay and my staff researchers ( Mr. Lalisa Ofgea. Mr. Roba Elema and Mr. Bane Kebede whom from HaramayaUniversty (HU) in technical support during sample collection and analysis the laboratory at HU laboratory. I would like thank Haramaya and Kombolcha office Agricultural and Natural resource for their willingness and offering me study location, by facilitatingthrough theirs SMS and DA at field and other support as per need. I like to extend my deepest appreciation and thanks to my wife SeadaJuneidy for her encouragement, considerable assistance, care and love during the study period.

## Reference

- Ali M.H. (2010). Fundamentals of Irrigation and On-farm Water Management. Springer Science +Business Media, LLC, 233 Spring Street, New York, NY 10013, USA): Volume 1: book pp.283.
- Ahmad Ashfaq and Faizan Ahmad, 2014.Study on Assessment of Underground Water Quality.*Int.J.Curr.Microbiol.App.Sci*(2014) 3(9) 612-616: <http://www.ijcmas.com>
- Al Obaidy AH, Kadhem AJ, Hamiza NH, Al Mashhady AA (2014) Assessment of ground water quality for drinking and agricultural uses in Mouqdadiya District, Diyala, Iraq. Eng Tech J 32: 2921-2936

- Al-Tabbal JA, Al-Zboon KK (2012) Suitability assessment of groundwater for irrigation and drinking purpose in the northern region of Jordan. *Journal of Environmental Science and Technology* 5: 274-290
- Awulachew, SeleshiBekele; Yilma, A D.; Loulseged, M.; Loiskandl, W.; Ayana, M.;Alamirew, T. 2007. Water resources and irrigation development in Ethiopia. Colombo, Sri Lanka: International Water Management Institute (IWMI) 66p. (IWMI Working paper 123)
- Ayers, R.S. and D.W. Westcot, 1985. Water quality for agriculture FAO irrigation and drain. Paper No 29(1): 1-109
- Bhat MA, Wani AS, Vijay K, Jyotirmaya S, Dinesh T, et al. (2018). An Overview of the Assessment of Groundwater Quality for Irrigation. *J Agri. Sci. Food Res* 9: 209
- Biswas A (1998). Environmental Planning Management and Development; Tata McGraw-Hill Publishing Company, New Delhi. pp.208–402
- CWT (2004). Clean Water Team, State Water Resources Control Board FACT SHEET 3.1.5.9. Color of Water Fact Sheet. pp 1-3
- Doneen, LD (1964) Water quality for agriculture. Department of Irrigation, University of California, Davis, USA.
- Durfer CN, Baker F (1964) Public water supplies of the 10 larger cities in the U.S. Geological Survey. *Water Supply* 1812: 364
- Eaton, F.M., 1950. Significance of carbonate in Irrigation waters. *Soil Sci.*, 67(3): 128-133
- FAO (1985, reprinted in 1989). Water quality for agriculture. FAO irrigation and drainage paper 29 Rev. 1. Food and Agriculture Organization of the United Nations, Rome, Italy
- FAO (1985b). Guidelines: Land Evaluation for Irrigated Agriculture. *Soil Bulletin* 55. Food and Agriculture Organization of the United Nations, Rome, Italy
- FAO (2013). Water quality for agriculture. Food and Agriculture Organization, Irrigation and Drainage Papers. <http://www.fao.org/docrep/003/t0234e/t0234e00.htm> (accessed on March 11, 2017)
- Gaurav Jha, O.P. Choudhary and RakeshSharda. 2017. Comparative effects of saline water on yield and quality of potato under drip and furrow irrigation. *Cogent journal: Cogent Food & Agriculture* (2017), 3: 1369345; [www.Cogent.com](http://www.Cogent.com)
- Gautam SK, Maharana C, Sharma D, Singh AK, Tripathi JK, Singh SK (2015) Evaluation of groundwater quality in the Chotanagpur Plateau region of the Subarnarekha River Basin, Jharkhand State, India. *Sustain Water QualEcol* 6:57–74. <https://doi.org/10.1016/j.swaqe.2015.06.001>
- Ghanem, M.E.; van Elteren, J.; Albacete, A.; Quinet, M.; Martínez-Andújar, C.; Kinet, J.M.; Pérez-Alfocea, F.; Lutts, S. 2006. Impact of salinity on early reproductive physiology of tomato (*Solanumlycopersicum*) in relation to a heterogeneous distribution of toxic ions in flower organs. *Funct. Plant Biol.* **2009**, 36, 125–136: <https://dx.doi.org/10.1071/FP08256>
- Gupta, S.K. and I.C. Gupta, 1987. Management of Saline Soils and Water. Oxford and IBH Publication Coy, New Delhi, India, pp: 399.
- Haydar, S., M. Arshad and J.A. Aziz (2009). Evaluation of Drinking Water Quality in Urban Areas of Pakistan: A Case Study of Southern Lahore. *Pak. J. Engg. Appl. Sci.*, 5:16-23
- Jalali M 2005. Nitrates leaching from agricultural land in Hamadan, western Iran. *Agriculture Ecosystem and Environment* **110**: 210–218.
- Joshi, D.M., A. Kumar and N. Agrawal, 2009. Assessment of the irrigation water quality of River Ganga in Haridwar District India. *J. Chem.*, 2(2): 285-292
- Kahlown, M.A, M.A. Tahir, H. Rashid and K.P. Bhatti (2006). Water Quality Status. Fourth Technical Report 2004-06, PCRWR, Islamabad
- Kelly W.P., (1951), Alkali Soils-Their Formation, properties and Reclamation.3rd edition. Reinhold Publ., New York, USA. 92.
- Kiremit, M.S.; Arslan, H. **2016**. Effects of irrigation water salinity on drainage water salinity, evapotranspiration and other leek (*Allium porrum*L.) plant parameters <http://dx.doi.org/10.1016/j.scienta.Sci. Horti> 2016.02.001-201, 211–217:
- Latha MR, Indirani R, Sheeba S, Francis HJ (2002). Groundwater quality of Coimbatore district Tamil Nadu. *J. Ecobiol.* 14(3):217-221



- Lucia Bortolini, Carmelo Maucieri, and Maurizio Borin 2018. A Tool for the Evaluation of Irrigation Water Quality in the Arid and Semi-Arid Regions: [www.mdpi.com/journal/agronomy](http://www.mdpi.com/journal/agronomy) : doi: 10.3390/agronomy8020023
- Mohammad Amin Bhat, M.S. Grewal, Ramprakash, RajpaulSheeraz Ahmad Wani and Ejaz Ahmad Dar. 2016. Assessment of Groundwater Quality for Irrigation Purposes using Chemical Indices <https://www.researchgate.net/publication/316063170> Indian Journal of Ecology (2016) 43 (2): 574-579.
- Muhammad Arshad and Aamir Shakoo, 2017. Irrigation Water Quality .Chapter 7 <https://www.researchgate.net/publication/320531819>
- Narsimha A, Sudarshan V, Swathi P (2013) Groundwater and its assessment for irrigation purpose in Hanmakonda Area, Warangal District, Andhra Pradesh, India. *Int J Res Chem Environ* 3:195–199
- Nas B. and Berkta A. 2006. Groundwater contamination by nitrates in the City of Konya, (Turkey): A GIS perspective. *Journal of Environmental Management* 79(1): 30–37
- Obiefuna G.I. and Sheriff A. 2011. Assessment of Shallow Ground Water Quality of PindigaGombe Area, Yola Area, NE, Nigeria for Irrigation and Domestic Purposes. *Research Journal of Environmental and Earth Sciences* 3(2): 131-141
- Purushothaman P, Rao MS, Kumar B, Rawat YS, Gopal K, et al. (2012) Drinking and Irrigation Water Quality in Jalandhar and Kapurthala Districts, Punjab, India: Using Hydrochemistry. *International Journal of Earth Sciences and Engineering* 5: 1599-1608
- Raihan, F. and J.B. Alam, 2008. Assessment of groundwater quality in sunamganj Bangladesh Iranian. *J. Environ. Health Sci. Eng.*, 6(3): 155-166.
- Raju NJ 2007. Hydrogeochemical parameters for assessment of groundwater quality in the upper Gunjanaeru River basin, Cuddapah District, Andhara Pradesh, South India. *Environmental Geology* 52:1067–1074.
- Ramesh K, Elango L (2012) Groundwater quality and its suitability for domestic and agricultural use in Tondiar river basin, Tamil Nadu, India. *Environmental Monitoring and Assessment* 184: 3887-3899
- Richards LA (1954) Diagnosis and improvement of saline and alkali soils. USDA Hand Book, No. 60
- Richards LA (1954). Diagnosis and improvement of saline and alkali soils. USDA Agric. Handbook, No.60, Washington
- Robinove, C.J., R.H. longfort and J.W. Brook, 1958. Saline water resource of North Dakota US Geol. Surv. Water Supply Paper 1428, pp: 72
- Sarkar, A.A. and A.A. Hassan, 2006. Water quality assessment of a groundwater basin in Bangladesh for irrigation use. *Pak. J. Biol. Sci.*, 9(9): 1677-1684.
- Sawyer GN and McCarty DL 1967. Chemistry of Sanitary Engineers. 2nd ed. McGraw Hill, New York, 518 pp.
- Shakoor, A., M. Arshad, A. Bakhsh and R. Ahmed (2015). GIS based assessment and delineation of groundwater quality zones and its impact on agricultural productivity. *Pak. J. Agri. Sci.*, 52:1-7
- Sappa G, Ergul S, Ferranti F (2014) Water quality assessment of carbonate aquifers in southern Latium region, Central Italy: a case study for irrigation and drinking purposes. *Applied Water Science* 4: 115-128.
- Singh SK, Srivastava PK, Pandey AC, Gautam SK (2013). Integrated assessment of groundwater influenced by a confluence river system: concurrence with remote sensing and geochemical modelling. *Water ResourManag* 27(12):4291–4313. <https://doi.org/10.1007/s11269-013-0408-y>
- Modi PN (2000) Water engineering and water power engineering. New Delhi Press, New Delhi, pp 339–360
- Sundaray S. K., B.B. Nayak and D. Bhatta, (2009), Environmental studies on river water quality with reference to suitability for agricultural purposes: Mahanadi river estuarine system, India case study, *Environ Monitor* 155:227-243 doi:10.1007/s10661-008-0431
- Szabolcs I, Darab C (1964). The influence of irrigation water of high sodium carbonate content of soils. In Proceedings of 8th international congress of ISSS, Trans, II, pp: 803-812
- Toumi N, Hussein BH, Rafrafi S (2015) Groundwater quality and hydrochemical properties of Al-Ula region, Saudi Arabia. *Environmental Monitoring and Assessment* 187: 84.
- U.S. EPA (United States Environmental Protection Agency) 1986. Quality criteria for water 1986, 1 May 1986, EPA 440/5-86-001

- WAPCOS (1990); WAPCOS (Water and Power Consultancy Services). 1990. Preliminary Water Resource Development Master Plan for Ethiopia, Volume III, Annex – A hydrology and hydrogeology, Volume V Annex J – Hydropower; high level estimates based on experts personal communication
- Westcott DW, Ayers RS (1985). Irrigation water quality criteria. In Irrigation with Reclaimed Municipal Wastewater: a Guidance Manual, Pettygrove GS, T. Asano T (eds). Lewis Publishers Inc., Chelsea, Mississippi.
- Wicox LV (1955) Classification and Use of Irrigation Waters. US Department of Agriculture, Washington DC, Circular No. 969

# Technical Performance Evaluation of Selected Small Scale Irrigation Scheme in Arsi and Western Arsi Zone

Fekadu Gemedu\*, Bayan Ahimed\*, Dinka Fufa, Asnake Tileye

Oromia Agricultural Research Institute, Asella Agricultural Engineering Research Center  
P.O Box 6, Asella, Oromia, Ethiopia

Correspondent authors email: [firogemedu07@gmail.com](mailto:firogemedu07@gmail.com) and [bayahm@gmail.com](mailto:bayahm@gmail.com)

## Abstract

*In Ethiopia small scale irrigation schemes play a vital role in improving the livelihoods of the smallholder farmers'. However, existing small-scale irrigation schemes face various problems related to operation and maintenance, water management and sustainability. This study was conducted to technical performance evaluation of selected Small Scale Irrigation Scheme in Arsi and Western Arsi Zone using irrigation performance indicators. For this two scheme selected were Bubisa from Lemu-Bilbilo district of Arsi zone and KomaArba from Adabadistrict of West Arsi Zone. From the study conducted on Bubisa and KomaArba irrigation scheme using performance indices such as conveyance efficiency (Ec), application efficiency (Ea), on farm water lost (ROR+DPF), storage efficiency (Es), overall efficiency (Eo) and distribution uniformity (DU) and finally identifying problems of the scheme. For these study three farmers' fields located at head, middle and tail of the two irrigation scheme were selected. From the result, parameters like Ec, Ea, on farm water lost (ROR+DPF), Es, DU and Eo were 67%, 60.27%, 39.73%, 89.59%, 90.50% and 39.77%, respectively for Bubisa irrigation scheme and 78%, 62.25%, 37.25%, 82.33%, 92.78% and 48.70% respectively for Bubisa irrigation scheme. Water Use efficiency (WUE) of Bubisa and Koma Arba scheme were 4.59 and 3.05kg/m<sup>3</sup>. This means that the yield from one meter cube of irrigation water for Bubisa irrigation scheme was higher than that of KomaArba irrigation scheme. Sustainability of Irrigation System of the Bubisa and Koma Arba schemes were decreased by 42.7% and 62.5% compared with the planned. Therefore, for the improvement of the irrigation system management and the irrigation practice frequent performance evaluation is very important and solves problems related to operation and maintenance, water management and sustainability.*

**Keywords:** Irrigation schemes, irrigation efficiency, conveyance efficiency, application efficiency,

## Introduction

Irrigation is one means by which agricultural production can be increased to meet the growing food demands in the country (Seleshiet *al.*, 2005). In Ethiopia, although irrigation has long practiced at different farm levels, there is no efficient and well managed irrigation water practice (Bayan, 2017). The reason could be little efforts made to investigate the irrigated land management and water use in the country. Even some research results have indicated that

sometimes no difference observed between rain fed and small scale irrigation user smallholders in their food security status (Markoset *al.*, 2019)

Improving irrigation performance to increase productivity is one of the main visions formulated by national and international organizations involved in water development. Water productivity for food production was a major issue at the second Water Forum held in March 2000 organized by the World Water Council in Hague, where a frame work for achieving water security was formulated. The conference set a target to increase food productivity of water by 30 percent by the year 2015(FAO, 2002). This goal calls for evaluation of irrigation schemes aimed at increasing farm performance. There is increasing pressure to improve the water use efficiency of irrigated agriculture in developing countries. Over irrigation and excessive drainage losses are wide spread. Significant water savings can be achieved with an integrated approach to irrigation and drainage management (Dinka,2017).

In Ethiopia small scale irrigation schemes play a vital role in improving the livelihoods of the smallholder farmers. However, existing small-scale irrigation schemes face various problems related to operation and maintenance, water management and sustainability. These problems have greatly reduced their benefits and challenged their overall sustainability (Seleshiet *al.*, 2007). Besides the poor performance of irrigation projects in the country, evaluation of irrigation projects is not common: lack of knowledge and tools used to assess the performance of projects adds to the problem(Taye, 2019).

Bubisa and Koma Arba small scale irrigation are one of small scale irrigation which are community managed small scale irrigation scheme that is developed for surrounding Farmers. However, due to lack proper water management, the farmers at the head irrigation scheme use over irrigation and that of the middle and tail face the shortage of water resulting conflicts on water users many times. Hence, this study was conducted on Bubisa and Koma Arba small scale irrigation with the objective of technical performance evaluating the schemes.

## **Materials and Methods**

### **Description of Study Area**

The study was conducted at Bubisa and Koma Arba Small scale irrigation Scheme. Bubisa scheme was located in Arsi zone of Lemu Bilbiloworeda and KomaArba scheme was located

at west Arsi zone of Adaba woreda of Oromia Regional State. From each scheme three farmers field located at head, middle and tail of the scheme were selected for evaluation.

### **Data Collection**

The secondary and primary data were collected. Secondary data collected were scheme design document and metrological data from Zone and National Metrological Agency. The primary data collected were physico-chemical properties of soil, water discharge measurement at head works, in main canals, at three field inlets and water application practices related to water management on field.

### **Soil parameters measurements**

The moistures were measured to determine how much water was depleted below the field capacity before irrigation and how much water was applied to the root zone after irrigation. For these purposes, soil samples for soil moisture content, bulk density, organic matter content, soil pH, texture, field capacity, and permanent wilting point of the soil were taken from two depths (0-30 and 30-60cm) and analyzed.

### **Bulk density**

Bulk density was determined using undisturbed composite soil samples collected from different locations with core samplers' volume of 98.4cm<sup>3</sup> at a depth of 0-30 and 30-60cm. The samples were placed in an oven and dried at 105°C for 24 hours. After drying, the soil and container were again weighed. The dry weight of the soil was analyzed by core method i.e. oven drying of the sample for 24 hours at 105°C and weighed for calculating dry density using equation (2.1) given by Hillel (2004)

$$\rho_b = \frac{M_s}{V_t} \quad 2.1$$

Where:  $\rho_b$  = soil bulk density (gm/cm<sup>3</sup>),

$M_s$  = mass of dry soil (gm)

$V_t$  = total volume of soil in the core sampler (cm<sup>3</sup>)

### **Soil Moisture Content**

Soil samples were collected to determine moisture content of soil from field before and after irrigation period using manually driven soil auger. The soil samples were placed in the air tight container and weighed prior to placing in an oven dry at 105 °c and were left in the oven

dry for 24hrs. After the soil moisture sampler collected and oven dried, the moisture was calculated as a percentage of dry weight of the soil (W) as stated Walker (2003).

$$W = \frac{M_t - M_s}{M_s} * 100 = \frac{M_w}{M_s} \% * 100 \quad 2.2$$

Where: W=weight of soil sample (gm)  
 $M_t$ =weight of fresh sample (gm)  
 $M_s$ =weight of over dried sample (gm)  
 $M_w$ =weight of moisture (gm)

To convert these soil moisture measurements into volumes of water, the volumetric moisture content ( $\theta$ ) was calculated as

$$\theta = \frac{\rho_b * W}{\rho_w} \quad 2.3$$

Where:  $\theta$  =volumetric moisture content (%),  
 $\rho_b$  = soil bulk density (gm/cm<sup>3</sup>),  
 $W$  = moisture content on dry weight basis (%),  
 $\rho_w$  = unit weight of water (1gm/cm<sup>3</sup>)

### **Total Available Water (TAW)**

Total available water is the water which crop can use for its normal functioning and survival. Then TAW was calculated as the following formula.

$$TAW = \frac{(FC - PWP)}{100} * BD * D \quad 2.4$$

Where: TAW = total available water (mm),  
 $FC$  = field capacity (% by weight bases),  
 $PWP$  = permanent wilting point (% by weight bases),  
 $D$  = depth of root zone (mm)  
 $BD$  = specific density of soil (bulk density of soil)

### **Soil Texture**

To determine soil texture, composite samples of disturbed soil were collected from different locations in the field and for the determination of soil textural class soil samples at the specified depths were taken at each stratum (head, middle and tail). Soil particle size composition of each composition was determined in laboratory. Based on the percentage of composition, the soil class was determined by USDA soil textural triangle method (Ziniabe, 2018).

## **Infiltration Rate**

Doubling ring infiltrometer method was used to identify the basic infiltration rate of the field soil. Ring infiltrometer are thin-walled, open-ended metal cylinders with the bottom-end sharpened to ease insertion into the porous medium. Ring infiltrometer were operated by inserting two rings (30 cm and 60 cm diameters were used) into the soil to a depth of 10 cm, ponding one or more known heads of water inside the rings, and measuring the rate of water flow out of the rings and into the unsaturated porous medium. Measuring rod graduated in mm (20 cm ruler) was used.

## **Crop Water Requirement (CWR) and Irrigation Water Requirement (IWR)**

The climatic data using CROPWAT model-8 was used to calculate the reference evapotranspiration ( $ET_o$ ) of the study area. In addition, mean monthly rainfall data of Bokoji Arsi and Adaba station were collected from National Metrological Agency. The monthly net crop water requirement (CWR) and the net irrigation water requirement (IWR) of the crop were computed by CROPWAT software.

$$ET_c = ET_o \times K_c \quad 2.5$$

Where,  $ET_c$  = crop evapotranspiration (mm/day),  $ET_o$  = reference crop evapotranspiration (mm/day) and  $K_c$  = crop coefficient

## **Flow Measurement**

### ***Canal Discharge Measurement***

Discharge measurement was done by float method at main and secondary canals. A tennis ball, plastic bottle and lemon were float on the surface of water. It was done by making mark off a known length of the 30m length interval. Release of the float material at upstream of the marker to reach last mark, the time it takes to pass between the two markers was recorded to calculate velocity. Ideally, it should time three passages of the float and average the three times a reduction factor of about 0.85 should be used to convert surface velocity to average velocity (Tigabu, 2017).

$$\text{Surface velocity } \left( \frac{m}{s} \right) = \frac{L}{t} \quad 2.6$$

$$\text{Average Velocity } \left( \frac{l}{s} \right) = \left( \frac{0.85 * L}{t} \right) \quad 2.7$$

$$A = y * b \quad 2.8$$

Where: b is base width of canal and y is water depth in the canal

Discharge can be calculated by multiplying average velocity and cross sectional area of the irrigation canal (Tigabu, 2017).

$$Q \left( \frac{m^3}{s} \right) = \frac{0.85 * L * A}{t} \quad 2.9$$

### Field Discharge Measurement

The flow of water into field was measured using 3" parshall flume to be installed at the entrance of the water flow to field. Then the flow depth observed on the flume was converted to the corresponding discharge using equation (2.10). Then the total volume of water applied ( $V_a$ ) was calculated using equation (2.11) (James, 1988) and the total depth of applied water was calculated based on the representative irrigated area.

$$Q = 0.1771H^{1.550} \quad 2.10$$

$$V_a = Q * \Delta t \quad 2.11$$

Where; Q= discharge through the flume (l/s), H= water depth in meter,  $V_a$ = total volume of water applied ( $m^3$ ),  $\Delta t$  =flow time to the field

### Determination of Irrigation System Performance Indicators

The performance of irrigation water management can be stated as “the extent to which the land and water resources in the irrigation schemes planned for allocation to different users and their spatial and temporal distribution in planning and operation stages follow the objectives of the irrigation scheme.

#### Conveyance efficiency ( $E_c$ )

The water conveyance efficiency is typically defined as the ratio between the irrigation water that reaches a farm or field to that of diverted from the water source and was calculated as expressed as (Irmak *et al.*, 2011):

$$E_c = \frac{V_f}{V_t} * 100 \quad 2.12$$

Where,  $E_c$ = Water Conveyance Efficiency (%),  $V_f$  = Volume of irrigation water that reaches the farm or field ( $m^3/s$  or ha-m) and  $V_t$ = Volume of irrigation water diverted from water source ( $m^3/s$  or ha-m)



### Application efficiency ( $E_a$ )

The application efficiencies ( $E_a$ ) in the selected fields were calculated using equation below (Hansen *et al.*, 1980).

$$E_a = \frac{D_s}{D_a} * 100 \quad 2.13$$

Where  $E_a$  = water application efficiency %,  $D_s$  = water stored in the soil root zone during the irrigation mm,  $D_a$  = water delivered to the farm mm

The depth ( $D_s$ , m) of water retained in the soil profile in the root zone was determined using the following equation given by (Markoset *al.*, 2019 as Cited by Misra and Ahmed 1990)

$$D_s = \sum_n i (\theta_{AI} - \theta_{BI}) i \frac{D_i}{100} \quad 2.14$$

Where:  $\theta_{AI}$  and  $\theta_{BI}$  are moisture content of the  $i^{\text{th}}$  soil layer after and before irrigation on oven dry volume basis (%), respectively.  $D_i$  is thickness of  $i^{\text{th}}$  soil layer (mm) and  $n$  is number of layer in the root zone.

### Storage Efficiency ( $E_s$ )

The water storage efficiency refers to how completely the water needed prior to the irrigation rootzone during irrigation. It is the ratio of water stored in the root zone during irrigation to the quantity of water needed in the root zone before irrigation. Based on the FC, PWP and bulk density of the soils of the selected irrigation fields and the root depth of the crop irrigated, the depth of irrigation water required by the crop was calculated as actual soil moisture depletion level (Allen *et al.*, 1998). After determining the water stored in the root zone of the plants and water needed in the root zone prior to irrigation, the storage efficiency ( $E_s$ ) was computed as

$$E_s = \frac{D_s}{D_{req}} * 100 \quad 2.16$$

Where;  $D_s$  is depth of water retained in the soil compartments of the root zone (mm) which is computed by equation 2.14 and  $D_{req}$  is water depth required in the root zone (mm) prior to irrigation and was estimate by the following equation:

$$D_{req} = \sum_n i \frac{1}{100} (\theta_{FC} - \theta_{BI}) * D_i \quad 2.17$$

Where;  $\theta_{BI}$  =  $i^{\text{th}}$  layer of volumetric moisture content before irrigation (fraction)  $\theta_{FC}$  =  $i^{\text{th}}$  layer of volumetric moisture content at field capacity (fraction)  $D_i$  =  $i^{\text{th}}$  layer of crop root depth (mm)  $n$  = number of layers in the root zone

### **Distribution Uniformity**

To determine the distribution uniformity of irrigation water in the selected farmer's field samples were taken from the selected points. For computing average depth of water infiltrated over the field ( $D_{av}$ ), moisture content of the field was measured before and after irrigation. Their difference and mean of their difference were calculated. For computing average depth of water infiltrated in the low one-quarter of the field ( $D_{1q}$ ), moisture content of the field was measured before and after irrigation. Their difference was calculated for the least four from descending order and then mean of their difference was computed. From  $D_{av}$  and  $D_{1q}$  distribution uniformity ( $D_u$ ) were computed for selected fields (by dividing mean of difference of overall sample for mean of difference of least quarter).

It was expressed as:

$$D_u = \frac{D_{1q}}{D_{av}} * 100 \quad 2.18$$

Where,  $D_u$ =Distribution Uniformity (%),  $D_{1q}$ =Average depth of water infiltrated in the low one-quarter of the field (m) and  $D_{av}$ = Average depth of water infiltrated over the field (m).

### **Overall scheme efficiency**

The most common way to express the efficiency of irrigation systems is to subdivide it into conveyance and application efficiencies. Once the conveyance and application efficiencies had determined, the scheme irrigation efficiency ( $E_o$ ) can be calculated, using the following formula (FAO, 1989).

$$E_o = \left( \frac{E_a * E_c}{100} \right) \quad 2.19$$

### **Irrigation water losses**

Irrigation water losses in canals are due to evaporation from the water surface, deep - percolation to soil layers underneath the canals, seepage through the bunds of the canals, overtopping the bunds, bund breaks, runoff in the drain, and rat holes in the canal bunds (In addition to these, the water losses in the cropped area are in the form of runoff and deep percolation

### **a) Runoff ratio (R.R)**

The amount of runoff from each field was collected and measured using known volumes of runoff collector buckets and parshall flume was installed at the lower end of the field and runoff was calculated using the equation given by Walker (2003) as;

$$RR = \frac{D_r}{D_a} * 100 \quad 2.20$$

Where: RR=runoff ratio (%),  $D_r$ =volume of runoff in terms of depth (mm) and  $D_a$ =total depth of water applied to the field (mm)

### **b) Deep percolation fraction (DPF)**

Deep percolation fraction (DPF) was calculated indirectly from the measured values of application efficiency ( $E_a$ ) and runoff ratio (RR) as given by FAO (1989);

$$DPF = 100 - E_a - RR \quad 2.21$$

## **Water productivity and relative irrigation supply of the scheme**

The water utilization by crop is generally described in terms of water use efficiency (kg/hacm, kg/m<sup>3</sup> or q/ha-cm) (Michael, 2008). Water use efficiency (WUE) and irrigation water use efficiency (IWUE) were determined by dividing the yield to seasonal ET and total seasonal irrigation water (IW) applied (Sinclair *et al.*, 1983).

$$WUE = \frac{Y_a}{ET_c} \quad 2.22$$

Where, WUE = water use efficiency (kg/m<sup>3</sup>),  $y_a$  is actual yield (kg/m<sup>2</sup>) and  $ET_c$  = seasonal crop evapotranspiration (m<sup>3</sup>/m<sup>2</sup>)

$$IWUE = \frac{Y_a}{IW} \quad 2.23$$

Where: IWUE- is irrigation water use efficiency (kg/m<sup>3</sup>),  $y_a$  - actual yield (kg/m<sup>2</sup>) and IW - irrigation water applied (m<sup>3</sup>/m<sup>2</sup>)

## **Sustainability of Irrigation System**

The simplest measure of sustainability is that quantifies the cumulative effect of negative impacts is “sustainability of irrigated area (SIA)” that may be calculated by the expression given by Nelson (2002) cited by Awel (2000) as;

$$SIA = \frac{AC}{AI} \quad 2.24$$

Where: AC= current total irrigated area, AI= total irrigated area when the system development way completed

## Data Analysis

Collected data during the test of the system were analyzed by descriptively using Micro soft excels.

## Results and Discussion

### Chemical Properties of Soil

From table 1 the textural class of soil for Bubisa scheme was Clay loam and that of KomaArba Scheme was clay. The soil pH, Electrical Conductivity and organic matter content values of Bubisascheme were 5.93, 0.200 and 3.19 and for Koma-Arba scheme 5.17, 0.098 and 3.22 respectively. From the result the soil was acidic for the two scheme but the Electrical Conductivity in the rage of recommended according to Garg, (2005) soil electrical conductive between 0.1 to 0.25 mmhos/cm at 25°C can be used for irrigation for almost all crops and for almost all kinds of soils.

Table: 1.Physio-chemical Properties of soil

Bubisa Scheme								
Location	pH	EC (mmhoms/cm)	OC%	OM %	Particle size (%)			Texture class
					Sand	Silt	Clay	
Head	6	0.15	1.91	3.3	26	39	35	Clay loam
Middle	5.9	0.23	1.82	3.14	20	40	40	Clay loam
Tail	5.9	0.23	1.82	3.14	22	38	40	Clay loam
<b>Average</b>	<b>5.93</b>	<b>0.20</b>	<b>1.85</b>	<b>3.19</b>	<b>23</b>	<b>39</b>	<b>38</b>	<b>Clay loam</b>
Koma-Arba Scheme								
Location	pH	EC (mmhoms/cm)	OC%	OM %	Particle size (%)			Texture class
					Sand	Silt	Clay	
Head	5.37	0.15	1.72	2.96	23	28	49	Clay
Middle	5.13	0.12	1.88	3.24	26	32	42	Clay
Tail	5.03	0.12	2.01	3.47	28	35	37	clay loam
<b>Average</b>	<b>5.17</b>	<b>0.13</b>	<b>1.87</b>	<b>3.22</b>	<b>26</b>	<b>32</b>	<b>42</b>	<b>Clay</b>

### Physical Properties of Soil

Table 2 blow show the physical properties of soil. Fromthe result the bulk density was1.38-1.31 g/cm<sup>3</sup> for Bubisa and 1.31to 1.26 g/cm<sup>3</sup> for KomaArba Scheme.Field capacity and Permanent wilting point of the soilwere 36.63% ,35.36%,32.02% and 22.5%,20.63% , 19.8%)

at head, middle and tail reach for selected farm field of Bubisa and 43.8% , 42.7% , 42.2% and 30.5%,28.7% , 28.4% Koma-Arba Irrigation scheme respectively. The average field capacity and permanent wilting point of Bubisa Irrigation Scheme 34.67% and 20.97% and were as for KomaArba Scheme were 42.9% and 29.2% respectively. In general the total available water holding capacity of soil in selected fields for Bubisa irrigation Scheme ranges 101.18-115.77 mm and KomaArba Scheme 104.33-108.36 mm.

Table:2 .Physical property of soil at Bubisa and Koma-Arba schemes

Property Location	Bubisa			Koma Arba		
	Head	Middle	Tail	Head	Middle	Tail
FC (%)	36.63	35.36	32.02	43.8	42.7	42.2
PWP (%)	22.5	20.63	19.8	30.5	28.7	28.4
Bulk Density(g/cm <sup>3</sup> )	1.33	1.31	1.38	1.31	1.29	1.26
depth (mm)	600	600	600	600	600	600
TAW(mm)	112.75	115.77	101.18	104.54	108.36	104.33

### **Infiltration Rate of Scheme**

The infiltration rate of the study area was found to be 7.2 and 3 mm/hr for the Bubisa and Koma-Arba irrigation schemes. The result shows that it was consistent with the report of Savva and Frenken (2002) that the basic infiltration rate of Clay loam is in the range of 5 to 10 mm/hr and for Clay is also 0 to 5 mm/hr. The soil being clay loam and clay moderately low infiltration rate had therefore, high water storage capacity.

### **Irrigation water requirements**

The potential crops in the study area were potato and evaluation was done on potato crop. The seasonal irrigation water requirements of potato were estimated for the two irrigation schemes were 218.2mm and 225.6mm for Bubisa and KomaArba Scheme respectively.

### **Field flow measurement**

During Farmer's field evaluation the area of selected farmers were 2500m<sup>2</sup> at three location for Bubisa scheme and 3063, 2750, 2687m<sup>2</sup> for Koma-Arba at head, middle and tail of scheme respectively. The average depth of water applied by a farmers during irrigation period were 234.44, 197.79 mm 194.42 mm and 247.56 mm, 226.79 mm and 200.59 mm at head, middle and tail of Bubisa and KomaArba Scheme respectively. This show that the farmers at head of irrigation scheme applied water above the irrigation water requirement of the crop.

## Irrigation Efficiency

### *Conveyance efficiency*

Conveyance efficiency of the systems was computed using equation (2.12) considering the total flow delivered by conveyance system and total inflow into the system. During the study period, average conveyance efficiency of the main canal from main intake up to the tail end was measured at different location along the canals using float-velocity method. The average conveyance efficiency values were 67% and 78% for Bubisa and KomaArba Irrigation Scheme respectively as indicated in (Table 3). The conveyance efficiency both schemes were below the recommended value i.e. 70% for poorly managed canals as stated by MoAFS (2002). This is due to the growing of weeds, theft of water and sedimentation deposited in canal which results canal linkage and water loss.

Table: 3 Average conveyance efficiency of main canals

Bubisa Irrigation Scheme								
Location	water depth(m)	Canal width(m)	A(m <sup>2</sup> )	L(m)	time (sec)	V(m/s)	Q(l/s)	Ec%
Diversion head work	0.09	0.5	0.05	30	84	0.35	17.5	
Head	0.09	0.53	0.05	30	102	0.29	14.5	83
Middle	0.08	0.52	0.05	30	120	0.26	11.65	66.5
Tail	0.07	0.51	0.04	30	138.6	0.22	8.8	50
<b>Average</b>								<b>67</b>
KomaArba Irrigation Scheme								
Location	water depth(m)	Canal width(m)	A(m <sup>2</sup> )	L(m)	Time (sec)	V(m/s)	Q(l/s)	Ec (%)
Diversion head work	0.25	0.37	0.09	30	114	0.26	23.40	
Head	0.23	0.41	0.09	30	126.07	0.24	21.60	92
Middle	0.18	0.43	0.08	30	123.35	0.25	18.30	78
Tail	0.13	0.44	0.06	30	120.63	0.25	15.00	64
<b>Average</b>								<b>78</b>

### **Application efficiency**

From table 4, the application efficiency of three locations of two schemes was indicated and values were (56.97%, 61.25%, 62.58%) and (60.45, 62.05, 65.75%) at head, middle and tail for Bubisa and Koma Arba schemes respectively. From the result high application efficiency was observed at the tail than head and middle for the two schemes although depth of water applied was high at head and middle. According to Bos (1997) the three irrigation location was in recommended value of 50-70% for furrow irrigation.

Table 4:- Average application efficiency

Bubisa				Koma Arba		
field code	d(mm)	Stored depth in mm	Ea %	d(mm)	Stored depth in mm	Ea %
Head	234.44	133.55	56.97	247.56	149.64	60.45
Middle	197.79	121.15	61.25	226.79	140.73	62.05
Tail	194.42	121.67	62.58	200.59	131.88	65.75
<b>Scheme Average</b>			<b>60.27</b>	<b>62.75</b>		

H= Head, M= middle, T= Tail d=water applied in field in mm Ea= application efficiency in %

### Storage efficiency

Storage efficiency refers to how completely the water needed prior to irrigation has been stored in the root zone during irrigation water application. Using equation (2.13) storage efficiencies ( $E_s$ ) were computed by monitoring soil moisture before and after irrigations. From table 5 storage efficiency of Bubisa irrigation scheme was 89.59% and that of KomaArba was 82.33%. According to Raghuwanshi and Wallender (1998), the recommended storage efficiency is 87.5%. Thus, the storage efficiency of Bubisa scheme was below recommended and Koma-Arba is in the range of recommended to fulfilling the soil moisture required for good productivity of the crops.

Table 5:- Storage efficiency the of Schemes

Bubisa Scheme				KomaArba Scheme		
Location	$D_{req}$ in (mm)	$D_s$ in mm	$E_s$ %	$D_{req}$ in (mm)	$D_s$ in mm	$E_s$ %
Head	133.55	124.19	92.99	149.64	131.36	87.79
Middle	121.15	110.85	91.50	140.73	122.44	87.00
Tail	121.67	102.55	84.29	131.88	95.23	72.21
<b>Scheme Average</b>			<b>89.59</b>	<b>82.33</b>		

$D_s$  = depth of water retained in the soil compartments of the root zone (mm)  $D_{req}$  = water depth required in the root zone (mm) prior to irrigation

### Distribution Uniformity

From Table 6, DU of the three locations of two irrigation schemes were 94.90%, 92.07% and 84.54% for Bubisa and 93.69%, 92.84% and 91.82% for KomaArba at head, middle and tail respectively. According to Irmak et al. (2011) DU less than 60% low and DU greater than 75% recommended. So the DU of the two irrigation schemes at three locations was greater than 75% so it is recommended. The result support to Eisenhauer (1997) distribution efficiency ( $\eta_d$ )  $\leq 60\%$  indicates that the irrigation water is unevenly distributed, while  $\eta_d \geq 60\%$  indicates that the application is relatively uniform over the entire field.

Table 6:- Distribution uniformity

Location	Bubisa				KomaArba			
	Soil moisture in descending order	Average	Lq	DU in %	Soil moisture in descending order	Average	Lq	DU in %
Head	17.34, 17.04 16.71 15.89	16.74	15.89	94.90	23.52 20.78 20.38 19.78	21.11	19.78	93.69
Middle	16.29 15.99 15.59 14.31	15.54	14.31	92.07	19.79 19.28 17.93 17.23	18.56	17.23	92.84
Tail	14.30 13.22 11.88 10.56	12.49	10.56	84.54	17.59 17.57 16.57 15.41	16.78	15.41	91.82
<b>Average</b>				<b>90.50</b>				<b>92.78</b>

Lq= Least quarter

### Overall scheme efficiency

From table 7 the overall efficiencies of the irrigation schemes at Bubisa and Koma Arba scheme were found to be 39.77% and 48.7%, respectively.. The overall efficiency of the Bubisa and Koma Arba irrigation scheme was within the range of values (40-50%) commonly observed in other similar African irrigation schemes (Savva and Frenken, 2002). And According to FAO (1989) overall scheme efficiency around of 40% is reasonable. Therefore the scheme was reasonable.

Table 7:- Overall application efficiency

Location	Bubisa Scheme			KomaArba Scheme		
	Ec	Ea	Eo	Ec	Ea	Eo
Head	83	56.97	47.29	92	60.45	55.61
Middle	66.5	61.25	40.73	78	62.05	48.40
Tail	50	62.58	31.29	64	65.75	42.08
<b>Average</b>	<b>39.77</b>					<b>48.70</b>

Ec= Conveyance efficiency Ea= Application efficiency Eo= Overall efficiency

### Irrigation water losses

The average water lost in the form of deep percolation and run off at Bubisa irrigation scheme were 39.73% and that of KomaArba scheme was 37.25%. From the result obtained a higher deep percolation ratio was observed in lower application. According to FAO (1989) 40 percent or more of the water diverted for irrigation is wasted at the farm level through either



deep percolation or surface runoff. so the result for Bubisa and Koma Arba Scheme agreed with the FAO (1989).

### **Water productivity and relative irrigation supply of the scheme**

The average irrigation water use efficiency for selected crop (potato) at head, middle and tail of Bubisa and Koma Arba Scheme were  $4.91\text{kg/m}^3$ ,  $4.26\text{kg/m}^3$ ,  $4.61\text{kg/m}^3$  and  $3.47\text{kg/m}^3$ ,  $3.15\text{kg/m}^3$ ,  $2.53\text{kg/m}^3$  respectively with overall average of 4.59 and  $3.05\text{kg/m}^3$ .

### **Sustainability of Irrigation System**

As per the design document, the intended command area that a Bubisa and Koma Arba Irrigation scheme could potentially irrigate 75ha and 160ha respectively, however the actual irrigated area was 43ha and 60ha for Bubisa and KomaArba scheme respectively. Hence, sustainability of irrigation calculated was 57.33% and 37.50% for Bubisa and KomaArba scheme using equation (2.24). Therefore, irrigated area of the Bubisa and Koma Arba schemes were decreased by 42.7% and 62.5% compared with the planned. This due to water diverted was lost along the canal and on farm water application was problem.

## **Conclusions and Recommendation**

### **Conclusion**

In Ethiopia, although irrigation has long practiced at different farm levels, there is no efficient and well managed irrigation water practice. From the study conducted on Bubisa and KomaArba irrigation scheme using performance indices such as conveyance efficiency ( $E_c$ ), application efficiency ( $E_a$ ), on farm water lost (ROR+DPF), storage efficiency ( $E_s$ ), overall efficiency ( $E_o$ ) and distribution uniformity (DU) and finally identifying problems of the scheme. For this study three farmers' fields were selected each from the head, middle and tail location of the two irrigation scheme. From the result Parameters like  $E_c$ ,  $E_a$ , on farm water lost (ROR+DPF),  $E_s$ , DU and  $E_o$  were 67%, 60.27%, 39.73%, 89.59%, 90.50% and 39.77%, respectively for Bubisa irrigation scheme and 78%, 62.25%, 37.25%, 82.33%, 92.78% and 48.70% respectively for Bubisa irrigation scheme.

From result conveyance water loss along the canal is high due to lined canal cracks and unlined canal. The result of the study also showed that the irrigation water applied to the farmer's fields was higher at head stream than the required depth to be applied per irrigation event without considering the crop water requirements of the crop. But the tail side of the

study area farm was stopped to irrigate due to water not reached there. Sustainability of Irrigation System of the Bubisa and Koma Arba schemes were decreased by 42.7% and 62.5% compared with the planned. Therefore, for the improvement of the irrigation system management and the irrigation practice frequent performance evaluation is very important.

### **Recommendation**

Huge amount of money invested to investment cost for construction of modern irrigation scheme and farmers must be expected to use water efficiently. The lined canal must maintained and unlined must be lined to reduce water loss along the canals and the district expert give training for farmers on water use and fix the schedule depending on crop water requirement to avoid excess field water application.

### **Reference**

- Allen R.G., Pereira L. S., Raes D. and Smith M. 1998. Crop Evapotranspiration:-Guidelines for Computing Crop Water Requirements. Irrigation and Drainage Paper, 56. FAO, Rome
- Awel Seid. 2000. Field management of the wessa small scale irrigation scheme, Southern Ethiopia. MSc Thesis, Haramaya University, Ethiopia
- Bayan Ahmed. 2017. Technical Performance Evaluation of Mada Batu Small Scale Irrigation Scheme ,West Arsi Zone of Oromia Region. Research Article ISSN : 2321-7758. International Journal of Engineering Research-Online, 5(3), 269–276.
- Bos G (1997) Performance indicators for irrigation and drainage, Irrigation and Drainage Systems 11: 119-120 of 50-70% for properly designed furrow
- DinkaFufa.2017 Technical Performance Evaluation of Ketar Medium Scale Irrigation Scheme , Southeast of Oromia Regional State , Ethiopia, 9(9), 13–21 <http://www.iiste.org/>
- Eidenhauer, D.E.,1997 .Irrigation performance Measures; Efficiency and Uniformity. Journal of Irrigation and Drainage Engineering,123,423-442
- FAO (Food and Agricultural Organization). 1998. Guidelines for investigation, design, construction, and management of irrigation schemes. FAO irrigation and drainage paper, 56, Rome, Italy
- FAO (Food and Agriculture Organization). 2002. Surface Irrigation Systems Planning, Design, Operation and Maintenance: - Irrigation Manual Module 7. FAO, Harare.
- Garg SK (2005) Irrigation engineering and Hydraulic structures.
- Hansen, V.E., Israelsen O.W., and Stringham, G.E., (1980). Irrigation Principles and Practices 4<sup>th</sup>
- Hillel, D. 2004. Introduction to Soil Environmental Physics.University of Massachusetts.ElisivierAcadamyPress . New York

- Irmak, S., Odhiambo, O.L., Kranz, L.W. and Eisenhauer, E.D. 2011. Irrigation Efficiency and Uniformity, and Crop Water Use Efficiency. Institute of Agriculture and Natural Resources, University of Nebraska– Lincoln.
- James, L.G. 1988. Principles of farm irrigation systems design. John Wiley and Sons. New York.
- Markos H., Shemelies A., and Sirak T. 2019. Performance Evaluation of Sanko Small Scale Irrigation Scheme at Basketo Special Woreda in SNNPR, Ethiopia. *Irrigat Drainage Sys Eng* 8:233.
- Michael, A.M. 2008. Irrigation Theory and Practice 2<sup>nd</sup> edition. Indian agricultural research institute, New Delhi.
- Mishra, R. D. and Ahmed, M. 1990. Manual on Irrigation Agronomy. New Delhi
- MoAFS (Ministry of Agriculture and Food Security, Irrigation Section), 2002. Assessment of Irrigation Efficiency in Traditional Small holder schemes in Pangani and Rufiji Basins
- Nelson, M. 2002. “Sustainability of small scale irrigation schemes: Traditional irrigation schemes in West Pokot, Kenya.” A draft Report to the Department of Range Management, University of Nairobi, Nairobi, Kenya
- Raghuwanshi, S. and W. Walender, 1998. Optimal furrow irrigation scheduling under heterogeneous conditions, *Agricultural Systems*, 56.
- Savva AP and Frenken K. 2002. Planning, Development Monitoring and Evaluation of Irrigated Agriculture with Farmer Participation, Modules: 1-14.
- Seleshi Bekele Awulachew, D.J. Merrey, A.B. Kamara, B. Van Koppen, F. Penning de Vries and E. Boelee. 2005. Experiences and Opportunities for Promoting Small-Scale/Micro Irrigation and Rainwater Harvesting for Food Security in Ethiopia. IWMI Working Paper 98. Colombo, Sri Lanka.
- Seleshi Bekele, Aster Deneke, Makonnen Loulseged, Loiskandl, W., Mekonnen Ayana, and Tena Alamirew. 2007. Water Resources and Irrigation Development in Ethiopia. Working Paper 123. Colombo, Sri Lanka.
- Sinclair, T. R. Tanner, C. B. and Bennet, J. M. 1984. *Water-Use Efficiency in Crop Production*. 34 (1), Oxford University Press, London, UK.
- Taye Minichil Meshesha. 2019. Evaluating and Comparing the Performance of Small Scale Irrigation Systems: Case Study Jedeb and Kulech Small Scale Irrigation Schemes in East Gojam Zone, Amhara, Ethiopia. Bahir Dar University Bahir Dar Institute of Technology. School Of Research and Postgraduate Studies.
- Tigabu T (2017) Performance evaluation of Loma small scale irrigation scheme in Tembaro Woreda.
- Walker, W. R. 2003. Surface irrigation simulation, evaluation and design. User guide and technical documentation, Utah state university, Logan, Utah, USA.
- Zinabie Mekonnen. 2018. Performance Evaluation of Small-Scale Irrigation Scheme. A case Study of Golina Small-Scale Irrigation scheme, North Wollo, Ethiopia).

## Post Harvest and Agricultural Product Processing Technologies

### Shelf Life Determination of Mango Juice Produce by Small-Scale Processing Techniques in Eastern Hararghe Zone

BayissaTarecha\* Abdulahi Umar

\*.<sup>2</sup>Oromia Agricultural Research Institute, Fedis Agricultural Research Centre, Agricultural Engineering Research Process, Harar, Ethiopia. \*Corresponding author E-mail: [tiqotarecha@gmail.com](mailto:tiqotarecha@gmail.com)

#### Abstract

Mangoes play an important role because they provide nutrients beneficial to human health. Fresh mangoes contain 83% water, 36mg/100g vitamin C, 15% carbohydrates (Guiamba, 2016) and other nutrients. The objective of this study was to estimate shelf life of mango juice produced using small-scale processing techniques. Juice was processed and packaged in 40 bottles and stored at (13-16)°C around haramaya and (22-25) °C around FARC. At each temperature, 10 bottles had preservative (0.5 mg/l citric acid) and 10 bottles had no preservative was stored. The juices were analyzed for pH, vitamin C, sensory attributes and microbial load at one month intervals up to end. From three month to four month, juices stored at (22-25) °C had lower pH (2.26-2.22), with preservative, (2.98-2.67) without preservative) than juices stored at (13-16)°C (3.12-2.87 with Preservative, 3.32 – 3.3 without preservative). At month four, vitamin C loss was highest (55.34 %) in juice without preservative stored at 22-25°C, followed by juice stored at with preservative (43.65%). The loss was lowest (26.98%) in juice with preservative stored at 13-16°C. Juices stored at (22-25)°C were rated 'bad' from week 6, in smell, color and taste while at that time, juices stored at (13-16)°C were rated 'almost similar' to fresh juice in smell (5.75) and taste (5.95 and 5.75). Storage at (13-16)°C with preservative resulted in lowest bacteria ( $3.3 \times 10^4$  CFU/ml) and yeast and mold ( $3.25 \times 10^6$  CFU/ml) counts whilst highest bacteria ( $2.22 \times 10^7$  CFU/ml) and yeast and mold ( $7.49 \times 10^6$  CFU/ml) counts were observed in juices stored at FARC without preservative. The shelf life was estimated based on taste and smell as 3 months and 4 months for juices stored at 30 °C and 13 °C, respectively. Cold temperature combined with use of preservative slowed down rate of vitamin C loss, deterioration of sensory attributes and microbial growth.

**Keywords:** mango juice, sensory evaluation, shelf life, small-scale processing, vitamin C

## Introduction

Mango (*Mangifera indica*) is one of the most popular and valued fruits in tropical countries and many parts of the world (Hassan & Kabir, 2014). Mangoes are utilized in a number of ways including being eaten fresh whilst green or when ripe or they can also be eaten as desserts, canned or used for making juice, jams and other preserves (Samson, 1986). In some cases, mature but not fully ripe mangoes are cut into slices and dried (Chitedze research station, 1998). Mangoes play an important role because they provide nutrients beneficial to human health. Fresh mangoes contain 83% water, 36mg/100g vitamin C, 15% carbohydrates (Guiamba, 2016) and other nutrients like vitamins A, B, E, folate and iron (Guiamba, 2016). They are also an excellent source of calcium, phosphorus and potassium (Guiamba, 2016; Mgaya-Kilima, Remberg, Chove, & Wicklund, 2014). Vitamin C is one of the major nutrients in mango juices in which its content can be up to 48mg/100ml (Falade, Babalola, Akinyemi, & Ogunlade, 2004). Vitamin C is an essential nutrient required for prevention of scurvy and maintenance of healthy skin, gums and blood vessels (Lee & Kader, 2000). Masamba & Mndalira (2013) reported similar results whereby juices with preservatives stored at 10 °C retained more vitamin C than juices with preservative but stored at room temperature. In addition, vitamin C has many biological functions including being an antioxidant with potential of reducing some forms of cancer (Lee & Kader, 2000) and preventing many degenerative diseases (Lund, Collins, & Dimon, 2000). However, vitamin C is most sensitive to destruction when commodity is subjected to adverse handling and storage conditions (Lee & Kader, 2000). Vitamin C decomposes rapidly in high temperatures and in the presence of oxygen and light (Jung, Williams, & Pillar, 1995; Mgaya-Kilima et al., 2014). Other factors that enhance vitamin C losses are extended storage, relative humidity, processing methods and cooking procedures (Lee & Kader, 2000). Because of vitamin C's instability, its content is used to indicate the presence of other nutrients and is considered as an indicator vitamin in food processing (Lund *et al.*, 2000; Guiamba, 2016).

Post-harvest changes associated with ripening and senescence and the effects of postharvest handling techniques make mangoes highly perishable. Therefore, a great proportion of mangoes are wasted during their season (Falade et al., 2004) due to spoilage when the mangoes are kept for a long time without processing. To prevent wastage of the seasonal fruit when it is in abundance, small scale processing techniques, pulp extractor and recipes for formulation of mango juices were developed, transferred and promoted to small-scale processors and the technologies were adopted (Chitedze research station, 1998). In Malawi,

the small-scale processing techniques of mango juice for commercial purposes were promoted by various governmental and nongovernmental organizations. However, the shelf life of the juices produced using these techniques was not established.

Shelf life of a food is the period of time under defined conditions of storage, after manufacture or packaging, during which a food product will remain safe and suitable for use (Man, 2002). During this time period, a food product should retain its sensory, chemical, physical, functional, microbiological and nutritional characteristics in optimal conditions in such a way that it is acceptable for a consumer (Man, 2002; NewZealand Government, 2014). Within the shelf life period, a product is expected to comply with any label declaration of nutritional information when stored according to recommended conditions (Man, 2002). The shelf life of any given product will depend on a number of factors such as its composition, processing methods, packaging and storage conditions (Man, 2002). Shelf life of any product can be determined by monitoring physical, chemical, microbiological and sensory changes occurring to the food during storage whereby measurable deterioration characteristics may be chosen (Institute of Food Science and Technology, 1993). Because the shelf-life of the juices produced using small-scale techniques was not yet established, problems exist during marketing because of labeling requirements and consumer safety considerations. Therefore, this study aimed at determining the shelf life of mango juice produced using small-scale processing techniques.

## **Materials and Methods**

### **Description of Area**

The experiment was conducted Fadis and Haramaya woredas. The fruit sample was collected from Fadis, Babilie. The study area found at about 523 km from Addis Ababa to eastern and located at 9.31 latitude and 42.12 longitude and situated at 1917 meters above sea level. The area experiences annual average rainfall of 700 mm for the lower kola to nearly 1200 mm for the higher elevation, as average temperature 27°C-35°C. Juice mixer, digital balance, sieve, bottle (jar), thermometer was materials used as well as sugar and citric acid were chemical used.

### **Preparation of the Mango Juice**

Mangoes which were fully ripe (based on yellowness and softness) and free from rot were selected and were cleaned and peeled, then pulp was extracted using a juice mixer and the pulp as well as peel was weighed. The pulp was mixed with water in the ratio of 1 part pulp to 2

parts water and the mixture was stirred for 5 minutes. The mixture was then sieved and weighed again. The mixture was then heated for 10 minutes at 65°C, followed by addition of white table sugar in the ratio of 90 g sugar per 1 liter juice mixture. Then the mixture was cooled below 15°C by placing in the container of the juice in a water bath containing chilled water. After cooling, the juice was divided into half and preservative (citric, 0.5 mg/l) was added to one portion the left was without preservatives. The juice was packed into 250 mL bottles. The bottles were treated by dipping in hot water at 60°C for 15 minutes prior to packing. Finally, 80 bottles containing the juice were divided in half was stored at room temperature under two location which was (22–25 )°C and (13–16 )°C Fadis research center and Haramaya university laboratory respectively.

The juice was packaged in 40 bottles of 250 ml each. Half of the bottles were stored in Haramaya at chilling temperature of (13–16)°C and the remaining was stored at FARC at average room temperature of (22-25) °C . At each storage temperature, 20 bottles contained a preservative (citric acid 0.5 mg/l) and the other 20 bottles did not have the preservative.



Fig.1 Bottled mango

### **Experimental design and statistical analysis**

The experiment was arranged to analysis under simple descriptive statistical, Storage temperature is factors. The treatment was prepared under two storage room temperature (Haramaya and FARC) storage place.

## **Data Collection**

The juice was monitored on PH, vitamin C, sensory and microbiological changes. Data collection was started soon after preparation of the samples and later on at three weeks intervals for 4 (four) month. Three (3) bottles were collected from each category (i.e stored at 13 °C with and without preservative and at 30 °C with and without preservative).

## **Determination of pH and Vitamin C**

AOAC (1984) methods were used to determine PH. The pH was measured using a PH meter (WTW PH 525, D. Jurgens and Co., Bremen, Germany) fitted with a glass electrode (WTW SenTix 97T). Vitamin C was determined and monitored using an AOAC (1984) method.

## **Sensory Evaluation**

Untrained Panelist selection was based on interest, availability, health and ability to discriminate four tastes (sweet, sour, salty and bitter). Panelists were trained before the testing sessions in order to develop a common understanding of terminologies and procedure during sensory evaluation. Consensus training as explained by Lawless and Heymann (1998) was conducted.

**Color** – Uniform orange color generally accepted for mango pulp and juice. Deterioration was indicated by change from orange to brownish

**Viscosity** – Referred to the thickness or thinness of the juice after agitation

**Smell** – Smell associated with fresh mango juice

**Taste** – Taste associated with fresh mango juice

Visual quality was examined in accordance with the sensory evaluation standards (Ma et al., 2010), untrained panelist were scored on a scale of 9 points (1-9). In which **1.** Like extremely, **2.** Like very much **3.** Like moderately, **4.** Like slightly, **5.** Dislike slightly, **6.** Neither like nor dislike, **7.** Dislike moderately, **8.** Dislike very much, **9.** Dislike extremely with this regarded every one month of stored period mangoes were tested by panelist and gave score as above rating scale.

## **Microbial Analysis**

From each sample, appropriate serial dilutions were made aseptically using sterile saline solution. The dilutions were used for enumeration of total bacteria on Nutrient Agar (Merck, Gauteng, South Africa). Pour plate technique was used and the plates were incubated at 30 °C for 48 h. Yeasts and molds were enumerated on Malt Extract Agar (Merck) using spread plate technique and the plates were incubated at 25 °C for 3–5 days.



## Results and Discussion

Table 1. Changes in pH during storage

Storage time (month)	Haramaya 13°C with preservatives	Haramaya 13°C without preservatives	Fadis 25°C with preservatives	Fadis 25°C without preservatives
0	3.82	3.82	3.82	3.82
1	3.67	3.91	3.22	3.45
2	3.54	3.68	2.82	3.12
3	3.32	3.12	2.26	2.98
4	3.3	2.87	2.22	2.67

### Changes in PH during Storage

The juices became acidic with increasing storage time, at four (4) month the pH was recorded lower for juices stored at FARC under average room temperature of (22-25) °C than juices stored at Haramaya districts of (13-16) °C (Table 1). The increase in acidity could be due to increase in organic acids following the temperature increased. In this case, the increase in acidity could be due to the activities of yeasts and bacteria whose load increased with increase in storage time.

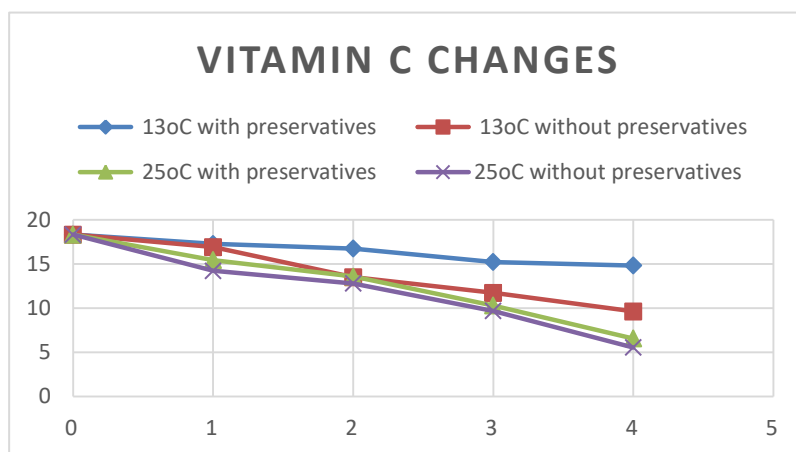

Fig.2 changes in vitamin C

### Vitamin C Content during Storage

Vitamin C content soon after extracting the pulp was 17.04 mg/100g and just after juice processing the content was 16.34 mg/100g. As we observed from graph Change in vitamin C content was dependent on temperature and presence or absence of preservative (Figure 2). By the end of four (4) month, loss of vitamin C was higher in juices stored at (22-25)°C i.e. contents were 5.5mg/100g in juice without preservative and 6.56mg/100g in juice with

preservative. In juices stored at (13-16)<sup>0</sup>C, the vitamin C contents were 9.63mg/100g in juice without preservative and 14.82mg/100g in juice with preservative.

The higher vitamin C losses at (22-25) <sup>0</sup>C than (13-16)<sup>0</sup>C (Figure 2) were due to store under high temperatures. These results agree with other studies in which increased temperature and storage time were associated with increased vitamin C losses (Mgaya-Kilima et al., 2014; Falade et al., 2004).

### Sensory Evaluation

Table 2. Average scores for sensory attributes of juices stored at the ends four month

Sensory parameters	Haramaya 13 <sup>0</sup> C with preservatives	Haramaya 13 <sup>0</sup> C without preservatives	Fadis 25 <sup>0</sup> C with preservatives	Fadis 25 <sup>0</sup> C without preservatives
Taste	4.2	7.1	5.6	7.45
Color	3.3	6.65	4.5	6.1
Smell	4.7	7.4	5.8	7.3
Viscosity	4.1	4.85	5.66	6.85
Overall acceptance	4	6	5	6.5

It was observed that prolonged storage (four month) resulted differences in all sensory attributes between fresh and stored juices. In general, juices stored at high had higher means than low temperature. Thus, increase in storage temperature resulted in rapid changes in all the quality attributes namely, color, viscosity, smell and taste.

**Color:** Color of the juices at both temperatures, and with and without preservative was rated 4.0 on the 1<sup>st</sup> and 2<sup>nd</sup> month. However, on the 3<sup>rd</sup> the color of juices stored at (22-25)<sup>0</sup>C with preservative changed slightly and while that of juices without preservative changed to brownish and the colors were rated 3.3 and 6.65 respectively (Table 2). These contribute to color change and off flavor in juices (Falade et al., 2004). The products of non-enzymatic browning are due to the reactions of sugars, amino acids and ascorbic acid and are present in mango juice (Falade et al., 2004).

**Viscosity:** Viscosity refers to the texture of a product. Products can be thick or thin depending on the nature of the product. Mango juices are thick soon after processing but become thin after storing the juice for some time. The first two month, there were no changes in the juices stored at Haramaya both with and without preservative. The use of preservative slowed down the rate of deterioration of the thickness of the juice.

**Smell:** Juice stored for 4 month at 13 °C smelled similar to fresh juice at (Table 2) while the juice stored at Fadis 25°C without preservative smelled badly compared to the juice with preservative stored at the same temperature. Deterioration in smell was perceived at one month in juices stored at Fadis 25°C while in juices stored at 13 °C, deterioration was noticed from two month (Table 2). The deterioration in smell could be due to non-enzymatic reactions which lead to production of off-flavors (Jimenez & Duran, 1999).

**Taste:** The taste of juices stored at Fadis 25 °C with preservative was slightly bad at week 5, the taste of the juice was extremely bad after week 7 (Table 2). While the taste of juice at Fadis 25 °C without preservative was bad at week 7 and extremely bad at two month. On the other hand, the juices at 13 °C were all still similar to fresh juice but the juice without preservative was bad and all juices were extremely bad.

### Microbial Analysis

Microbial activities result in production of by-products, which can influence changes in sensory quality of juices during storage. Table 3 indicates the number of bacteria present in the juice from week 0 to month 4.

Table 3. Total aerobic bacteria counts in mango juice during storage

Bacterial count (CFU/ml)				
Storage time (month)	13°C with preservatives	13°C without preservatives	25°C with preservatives	25°C without preservatives
0	$3.82 \times 10^3$	$3.82 \times 10^3$	$3.82 \times 10^3$	$3.82 \times 10^3$
1	$4.3 \times 10^3$	$3.91 \times 10^4$	$3.22 \times 10^4$	$3.45 \times 10^4$
2	$5.4 \times 10^3$	$3.68 \times 10^4$	$2.82 \times 10^5$	$3.12 \times 10^6$
3	$6.32 \times 10^3$	$3.12 \times 10^7$	$2.26 \times 10^6$	$2.98 \times 10^7$
4	$3.3 \times 10^4$	$2.87 \times 10^8$	$2.22 \times 10^7$	$3.69 \times 10^8$

There were differences in bacteria counts in juices with and without preservative at the two temperatures. The results indicate lower microbial load in juices with preservative and stored at 13°C than in juices without preservative and stored at 25 °C. The results agree with the fact that preservatives play an important role in preventing microbial growth by slowing down the rate of multiplication of the microbes (Henney, Taylor, & Boon, 2010).

The initial mean population was approximately  $3.82 \times 10^3$  cfu/ml and after month 4, the mean populations were highest,  $3.69 \times 10^8$  cfu/ml, in juices stored at fadis at 25°C without preservative and lowest,  $2.04 \times 10^4$  cfu/ml, in juices stored at 13 °C with preservative. However, the quality of all the juices, except the chilled juice containing preservative, could

be considered unsatisfactory by the end of the fourth month. Total aerobic counts are used as indicators of quality and counts  $>10^4$  cfu/ml can provide useful information about the general quality and remaining shelf life of the juice in question. When total aerobic counts are used to indicate quality, counts of  $10^4$  cfu/ml indicate upper limit of acceptability (Center for Food Safety, 2014).

Table 4. Yeasts and molds count in mango juice during storage

Yeasts and molds count (C FU/ml)				
Storage time (month)	13°C with preservatives	13°C without preservatives	25°C with preservatives	25°C without preservatives
0	$3.625 \times 10^3$	$2.3 \times 10^4$	$1.467 \times 10^4$	$2.497 \times 10^3$
1	$4.3 \times 10^3$	$7.05 \times 10^4$	$2.825 \times 10^4$	$4.2 \times 10^4$
2	$1.23 \times 10^4$	$2.99 \times 10^5$	$2.94 \times 10^5$	$1.64 \times 10^6$
3	$3.05 \times 10^5$	$4.11 \times 10^5$	$9.943 \times 10^5$	$2.78 \times 10^7$
4	$3.25 \times 10^6$	$3.66 \times 10^7$	$7.49 \times 10^6$	$2.72 \times 10^7$

Spoilage in fruits and fruit juices is mostly caused by yeasts contamination mainly due to low acidity. Foods that have low acidity can be spoiled by yeasts because yeasts are most tolerant to acidic conditions being able to grow at pH as low as 2.5 (Praphailong & Fleet, 1997). It is suggested that spoilage occurs when yeast and mold count reaches  $10^5$  cfu/ml. At this limit, color, viscosity, smell and taste of the food are affected by the microorganisms in which case spoilage would have occurred (David & Norah, 1998). The initial mean population of yeast and molds was  $1.4 \times 10^2$  cfu/ml (Table 4). At week 6, the mean population was highest,  $1.96 \times 10^8$  cfu/ml, in juices stored at (22-25) °C without preservative and lowest,  $1.71 \times 10^4$  cfu/ml, in juices stored at (13-16)°C with preservative. By week 4, all juices, except the chilled with preservative, had yeast counts  $>10^5$  cfu/ml indicating some degree of spoilage.



Fig 3. Mold and yeast variation, and Colony forming unit of bacterial and fungal cells

## Conclusion

These results confirm that temperature and preservatives have significant effects on quality of juice during storage. At higher temperature and without preservative, the juices promoted a faster microbial growth, deteriorated faster in sensory attributes and had a higher rate of quantitative and qualitative loss. A combination of cold storage and use of preservative resulted in highest vitamin C retention during storage. Therefore, based on deterioration of taste, the shelf life were estimated to be two (2) month and four (4) month for juices stored at FARC (22-25)<sup>o</sup>C and Haramaya (13-16)<sup>o</sup>C respectively. The study underscored the importance of using sensory analysis, particularly attributes like taste and smell, alongside instrumental and microbial analyses in shelf life studies.

## Recommendation

Therefore, based on laboratory result and sensory test the upper limit of the prepared mangoes juice was to be 2.5 month and 4 month for at 25 °C and 13 °C, respectively. So that any small scale processor can use the processing mango fruit under recommended temperature with listed preservative to extend the shelf life of the juice.

## References

- Centre for Food Safety. (2014). Microbiological Guidelines for Food (For ready-to-eat food in general and specific food items). Revised. Food and Environmental Hygiene Department. [http://www.cfs.gov.hk/english/food\\_leg/files/food\\_leg\\_Microbiological\\_Guidelines\\_for\\_Food\\_e.pdf](http://www.cfs.gov.hk/english/food_leg/files/food_leg_Microbiological_Guidelines_for_Food_e.pdf) last accessed: July 2016.
- Chitedze. (1998). *Recipes for fruit juice production*. Chitedze, Lilongwe, Malawi.
- David, P. C., & Norah, H. (1998). *Fruits in Africa*. Aspen publishers, UK
- Falade, K. O., Babalola, S. O., Akinyemi, S. O. S., & Ogunlade, A. A. (2004). Degradation of quality attributes of sweetened Julie and Ogbomoso mango juices during storage. *European Food Research Technology*, 218, 456-459. <http://dx.doi.org/10.1007/s00217-004-0878-5>
- Guiamba, I. (2016). Nutritional value and quality of processed mango fruits (Doctoral thesis, Chalmers)
- Henney, J. E., Taylor, C. L., & Boon, C. S. (eds). (2010). *Strategies to reduce sodium intake in the United States*. Washington (DC): National Academies Press, USA. <http://dx.doi.org/10.17226/12818>
- Jimenez, K., & Duran, C. (1999). *Principles of food chemistry* (2nd ed.). University of Guelph, Canada.
- Lawless, H. T., & H. Heymann. (1998). Pp. 341-378 in *Sensory evaluation of food: principles and practices*. Chap. 10. Chapman & Hall, New York, NY.

- Lund, B. M., Collins, P., & Dimon, Z. (2000). *The microbial safety and quality of foods*. Aspen Publishers Ltd, Maryland.
- Man, D. (2002). Food Industry Briefing Aeries: *Shelf life*. Blackwell Science Ltd, London, U K.  
<http://dx.doi.org/10.1002/9780470995068>
- Masamba, K. G., & Mndalira, K. (2013). Mgaya-Kilima, B., Remberg, S. F., Chove, B. E., & Wicklund, T. (2014) *Food Science & Nutrition*, 2(2), 181-191.  
<http://dx.doi.org/10.1002/fsn3.97>
- New Zealand Government. (2014). <https://www.mp.govt.nz/document-vault/3414> Last accessed 2 March 2016.
12. Praphailong, W., & Fleet, G. H. (1997). *Food Microbiology*, 14, 459-468.  
<http://dx.doi.org/10.1006/fmic.1997.0106>

# Renewable Energy Technologies

## Adaptation and Evaluation of Pyrolysis Kiln Bone char Based Indigenous Fertilizer

Getachew Hailu wondimagegn<sup>1</sup>, Shemsedin Abubeker<sup>2</sup> and Girum Merga<sup>3</sup>

1, 2, 3 Oromia Agricultural Research Institute, Asella Agricultural Engineering Research center,  
Renewable Energy Research Case team, Oromia, Ethiopia.

### Abstract

*Developing countries are highly dependent on importing of NPK fertilizer which is unaffordable to buy by small holder farmers. Importing inorganic fertilizer is emptying the foreign exchanges stocks of developing countries. The possible solution, biomass for the developing countries is the back bone as a primary energy source. The objective of this study was adapt and evaluate bone pyrolysis kiln for indigenous based fertilizer to help the small holder farmers in developing countries through organic fertilizer supply, improving the poor soil fertility, and subsequently reduce agricultural carbon emission and sequester atmospheric carbon. Biochar produced from bone pyrolysis combines the advantages of biochar along with phosphorous addition. An experimental investigation has been carried out in this regard for biochar production from bone pyrolysis. The bone pyrolysis kiln produces uniformly heated bone char at low fuel consumption, as well as 20 to 35kg/one run of bone char as by product. The bone char produced had high PH when it is produced at high pyrolysis temperature. The bulk density of the bone char was also reduced with increasing temperature.*

**Key words:** *Biochar, bone char, soil fertility, indigenous fertilizer, Pyrolysis kiln, Bone Pyrolysis and pyrolysing temperature*

### Introduction

Globally 2.6 billion people worldwide and accounts for 20 to 60% of the gross domestic product of many developing countries, depend on agriculture (Alexandratos, N. et al A 2012). To fulfill world population diets a climate resilient, better preserved soil fertility and freshwater flows, less impact on deforestation and biological diversity, high GHG sequestration ability(or/carbon sink) and sustained agriculture system is required.

Biochar becomes the solutions of the future agriculture which supposed to fulfill food demand of more than ten billion people by 2050 (Hoffman, U. 2011). When biomass is decomposed

thermally biochar is produced in addition to CO<sub>2</sub>, combustible gases (mainly H<sub>2</sub>, CO, CH<sub>4</sub>), volatile oils tarry vapors. Global carbon dioxide (CO<sub>2</sub>) emission is increased by 0.7Gt or 2% at 2014 than recorded 35.3billion tones (Gt)CO<sub>2</sub> at 2013. It was relatively higher than the increment at 2013 by 0.6Gt CO<sub>2</sub> (or 1.7%) compared with 2012 (Olivier JGJ et al. 2014). During this process heat, flammable gases and liquids are produced together with a solid residue, biochar (S. P. Sohi, et al. 2010).

Pyrolysis kilns are used in wide application as incinerators, for the combustion and destruction of materials such as solid and liquid hazardous waste, medical waste, contaminated soils, waste sludges and municipal solid waste. The kiln is heated to high temperatures and as material passes through the kiln, waste is evaporated, organic materials are decomposed and combustion begin (Ye Min Htut, 2017).

The bone pyrolysis kiln also produces uniformly heated bone char at low fuel consumption, as well as 15-20Kg of bio char as by product. The bone char produced had high PH when it is produced at high pyrolysis temperature. The bulk density of the bone char was also reduced with increasing temperature (Henok Atile, 2016). In addition to biochar which supplies organic carbon and nutrients, plants require phosphors fertilizer. hence recovering phosphors from organic waste like bone and converting it through pyrolysis into fertilizer is necessary

With increasing pyrolysis temperature the calcium phosphate (CaP) crystallite and total phosphors product solubility decreases (Marie J Zwetsloot et al. 2014).

Developing countries like Ethiopia are highly dependent on importing of NPK fertilizer which is unaffordable to buy by small holder farmers. Importing inorganic fertilizer is emptying the foreign exchanges stocks of developing countries. The possible solution, biomass for the developing countries is the back bone as a primary energy source. For instance Ethiopians 80% of energy need is covered by biomass (Dawit and Diriba Guta. 2012).

So it is essential to design value-added biochar materials that can supply nutrients to soil over long period of time with minimum loss of biochar and nutrients. Therefore objective of the study was to adapt pyrolysis kiln technology for bone char preparation & produce bone char based indigenous fertilizer



## **Materials and methods**

### **Materials**

Materials and apparatus used for this experiment were:

- sheet metals, flat irons, square pipes, angle iron, water pipe, Cement and brick stone
- Bone, Stop watch, Spring type balance, Digital thermometer
- K-type thermocouple probe
- Hygrometer
- Anemometer & Fuel wood

### **Experimental Site description**

The test was conducted in Asella AERC with the local atmospheric conditions of ambient temperature 20-26.6oc, Air pressure 75.7Pka, Relative humidity 35% and Altitude/elevation 2430m.

### **Pyrolysis Kiln Construction**

Bone pyrolysis kiln – pyrolysis part fabricated in AAERC work shop from 2mm sheet metal size and Combustion part constructed from bricks that available in our center. Pyrolysis kiln was constructed considering easy loading and unloading of the material (bone) by designing an easy sliding material holding unit which slides in and out of the main pyrolysis cylinder. The kiln has gas exhausting pipe which takes the combustible gasses (produced during the pyrolysis reaction of the bone) directly to the combustion chamber. The kiln also has manually driven rotating paddle which helps to mix the bone during pyrolysis process for uniform heating of the bone. In addition the pyrolysis chamber was covered by the bricks building which has combustion chamber. In order to control the air supply to the combustion chamber a piece of sheet metal was put on the opening.

### **Experiment Set-Up**

- Tests were conducted using a biomass fuel Eucalyptus (local name bargamo ) with a 2cm \*2.6 cm cross section and a height of 137 cm
- Real-time temperature data was acquired by type K thermocouples installed at pyrolysis chamber
- The test includes measurement of fuel-wood consumed for each test pre-weighed quantities of the same size in average of fuel-wood and bone
- Quantity ,quality fuel-wood was measured before and after pyrolysis using a hanging, spring scale
- A batch of firewood and bone was set aside and weighed before for each test of process

## **Fuel characteristics**

The wood used for the experiments was Eucalyptus (local names bargamo) obtained from available area, split and air-dried. The moisture content (12.25%) and the calorific value of fuel wood (4090cal/gram) were determined at the end of the entire series of experiments by using oven drying method and bomb calorimeter respectively.

## **Production of bone char**

- Raw bone had been collected from the waste dump sites and hotels of Asella town.
- The collected bone should be dry and it did not have meat on it to avoid contamination and bad smell of rotten meat.
- Then the dried bone should be crashed in to small pieces which was less than five or six centimeter.
- Pyrolysis of bone was done by the new built pyrolysis kiln using fire wood combustion as energy source and heating the bone through radiation and conduction heat transfer.
- Combustible gas leaves the cylinder through the pipe and returns in to the combustion chamber and reduces the fuel consumption to pyrolysis it
- Every five minute the paddle was rotated manually, to mix the bone and facilitate the process
- The temperature of the bone was measured using k-type thermocouple, which is connected with thermometer
- In addition to biochar which supplies organic carbon and nutrients, plants require phosphors fertilizer.
- hence recovering phosphors from organic waste like bone and converting it through pyrolysis into fertilizer is necessary
- With increasing pyrolysis temperature the calcium phosphate (CaP) crystallite and total phosphors product solubility decreases (Marie J Zwetsloot et al. 2014).



Figure 1: Steps to produce bone char using pyrolysis kiln

### Results and Discussion

The purpose of this study was to design, built and test a bone pyrolysis kiln and bone char based indigenous fertilizer making technology for linking renewable energy with climate smart agri-culture. It further examined the quality and characteristics of the products (i.e. Bone char) for their PH, Temperature distribution, product yield per hour and energy consumption.

## Bone Pyrolysis

Pyrolysis process is an energy intensive process. In average, 12.25% moisture content fire wood was used in the pyrolysis experiment. During the first test of pyrolysing bone, it consumes about 105 Kg of fire wood and there was a lot of smoke almost all over the body of the bricks building. This was due to the building was wet and the drying process of it required more energy than required to pyrolysis the bone.

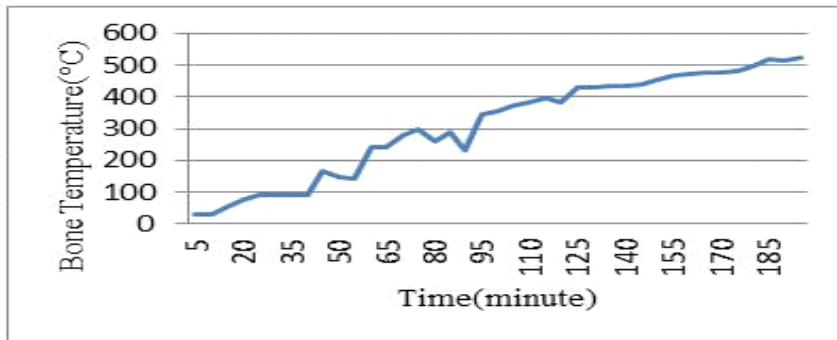

Figure 2: Temperature distribution of bone char with respect to time (at first test)

At second test the bone temperature reaches 500°C within 140 minutes (Figure-below) and the fuel consumption reduces to 60Kg. After the first two tests, the bone temperature gets 500°C within 105 minutes.

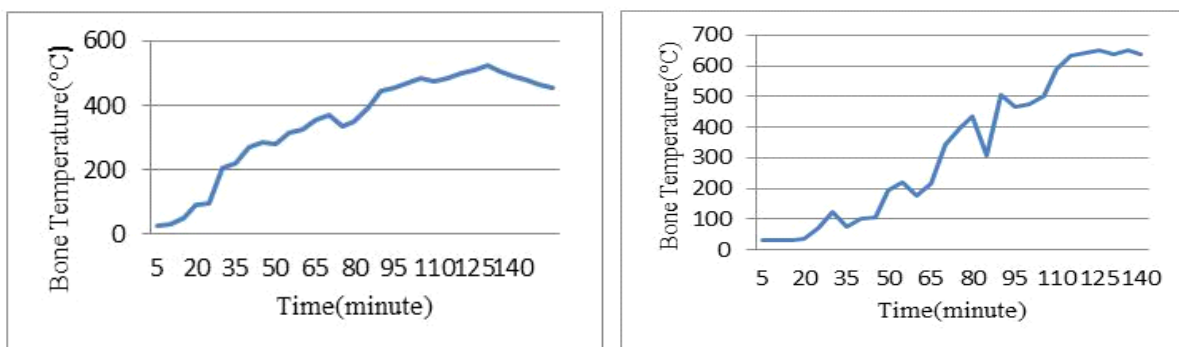

Figure 3: Temperature distribution of bone char with respect to time (at second & third test respectively)

Gasses start to come out from the pyrolysis chamber through the exhaust pipe after 40 minutes of pyrolysis. Though the gasses come out at this time, it didn't burn. Because, the bone was not completely dried and the gases has water vapor. After 50 minutes the pressurized combustible gasses starts to come out and gives very high combustion, even at low rate of fire wood addition.

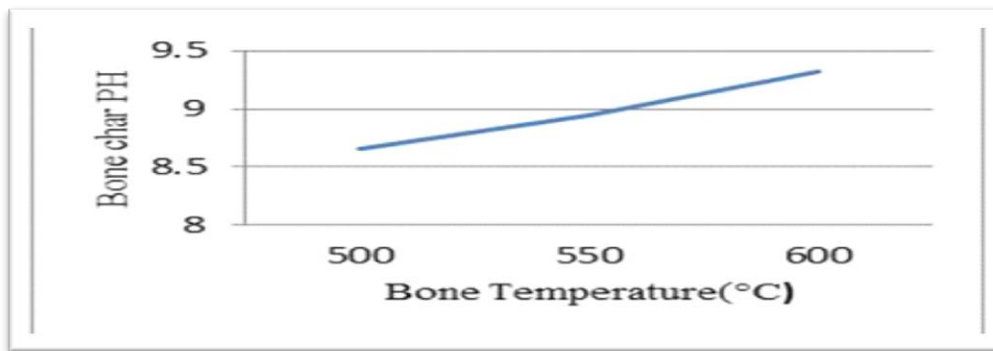

Figure 4: Effect of temperature on bone char PH

The bone char should be prepared based on the requirement of the PH of the bone char. Because, PH of bone char has the effect of increasing or lowering the soil PH. As the graph of PH of the bone char shows in figure-above, the PH increases with increasing pyrolysis temperature and time. Hence it is important to apply bone char in to the soil considering its' PH.

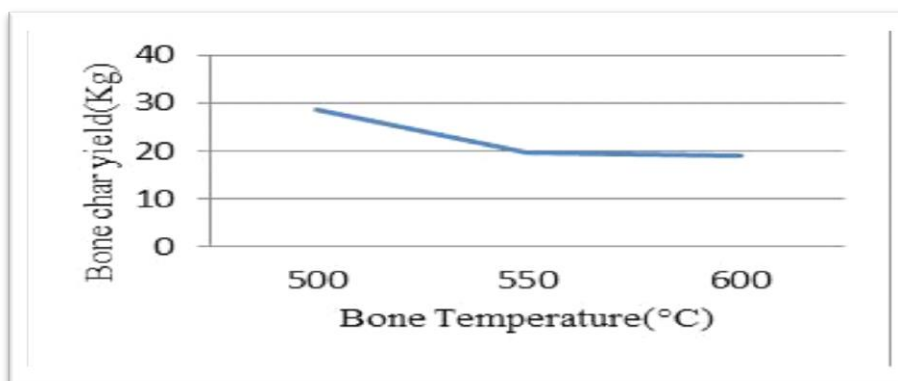

Figure 5: Bone char yield at different Temperature

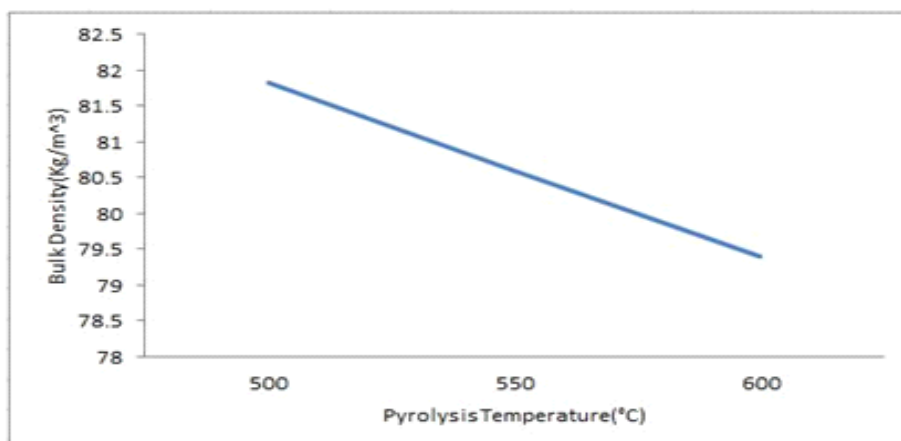

Figure 6: Effect of pyrolysis temperature on bulk density of bone char

Making bone char at higher temperature incurs more cost on the fertilizer cost, due to the high amount of fire wood consumption. The fuel consumption increases with increasing pyrolysis temperature. The longer the time it took to pyrolysis, the higher the fuel consumption to maintain the required pyrolysis temperature. In addition the bone char yield reduces with increasing pyrolysis temperature. The decrease in the bone char yield with the increasing temperature and Charring time could be due to greater primary decomposition of the bone at higher temperature.

Bulk Density of bone char was also measured and compared with relation to temperature. Besides the fact that it depends on the spatial arrangement of particles in the container, the pyrolysis temperature had high effect on it. As shown in the figure 6-above bulk density of bone char reduces at high pyrolysis temperature.

### **Conclusion**

Compared to the kiln built before which does not have rotating paddle, Fire wood consumption is much lower, easy for operating, easy for loading and unloading of the material(bone).The bone pyrolysis Kiln built which took less than 5hour to get 500oC. The bone char was produced from 500 to 650oC and the PH was increased with increasing pyrolysis temperature. The fuel consumption increases with increasing pyrolysis temperature. The decrease in the bone char yield with the increasing temperature and Charring time could be due to greater primary decomposition of the bone at higher temperature.

### **Recommendation**

The bone pyrolysis kiln have a lot of combustible gasses emission from the pyrolysis chamber, and because, the methods that to control syngas from Pyrolysis chamber with material that locally available and easily manageable is problem so that it need more investigation method to control syngas .The production capacity of the kiln is also only 20 to 35kg/one run, Considering this problems of the kiln and future mass bone char production, it is necessary to think about future requirement and design continuous production pyrolysis kiln. Also further adaption for other biomass like corn cob, woodchips, and saw-dust, coffee husk & so on.

## Reference

- Alexandratos, N. and Bruinsma, J. (2012). World agriculture towards 2030/2050, the 2012 revision. (ESA working paper No. 12-03). Rome, Italy: Food and Agriculture Organization of the United Nations.
- [2] Hoffman, U. (2011) Assuring food security in developing countries under the challenges of climate change: Key trade and development issues of a fundamental transformation of agriculture. (Discussion Paper No. 201). Geneva: United Nations Conference on Trade and Development.
- [3] Olivier JGJ, Janssens-Maenhout G, Muntean M. and Peters JAHW (2014), Trends in global CO<sub>2</sub> emissions; 2014 Report, The Hague: PBL Netherlands Environmental Assessment Agency; Ispra: European Commission, Joint Research Centre.
- [4] S. P.Sohi, E. Krull, E. Lopez-Capel, and R. Bol. A Review of Biochar and Its Use and Function in Soil. Elsevier. Vol. 105. Burlington: Academic Press, 2010, pp.47-82. ISBN: 978-0-12-381023-6
- [5] Henok Atile , 2016 Design, fabrication and sensitivity testing of an efficient bone pyrolysis kiln and biochar based indigenous fertilizer pelletizing machine for linking renewable energy with climate smart agriculture
- [6] Marie J Zwetsloot, Johannes Lehmann and Dawit Solomon. (2014). Recycling slaughterhouse waste into fertilizer: how do pyrolysis temperature and biomass additions affect phosphorus availability and chemistry? (wileyonlinelibrary.com) DOI 10.1002/jsfa.6716.



# Modification and Evaluation of Cardboard and Basket Model Solar Cooker

Gutu Birhanu Oliy\*, Gemechis Mideksa Adunya, Usman Kedir Gada

*Oromia Agricultural Research Institute, Bako Agricultural Engineering Research center,  
Bako, Oromia, Ethiopia* \*corresponding author e-mail: - [gtbr2006@gmail.com](mailto:gtbr2006@gmail.com)

## Abstract

*Cooking in developing countries is customarily done on open fires using biomass such as firewood, charcoal, and kerosene. This process inevitably leads to excessive deforestation in these rural regions as well as considerably increases carbon-dioxide emissions too. Cooking food engaging solar energy is currently seen as a viable alternative to the use of fuel wood, gas, oil and other fuels traditionally used for the purpose of preparing food. Cardboard and Basket solar box cooker were manufactured with incorporating insulation materials that enhance or boost heat transfer and preservation of heat in solar cooker. Totally about six prototypes were constructed and performance evaluation of all solar cookers was tested. Performance of solar cookers were conducted with cooking power, standard cooking power and efficiency of cooker with cooking rice, maize and faba bean separately and by mixing each other. All solar cookers were seriously tested with loading and unloading condition in order to identify their cooking performance. Accordingly at end of rice cooking, box solar cooker insulated with Styrofoam showed superior cooking with average cooking power, standard cooking power and efficiency of 657.15, 514.77 and 0.2034 respectively. Whereas for cooking maize with faba bean, box solar cooker insulated with Styrofoam showed superior cooking with average cooking power, standard cooking power and efficiency of 608.23, 637.01 and 0.1421 respectively with best cooking efficiency. In all solar cookers' maximum temperature rating of above 60 degree Celsius was attained which is better temperature for cooking of various food stuff with short time.*

**Key words:** Box, Basket, Solar, Cooker

## Introduction

Solar energy has come to public attention in recent year as it understood the picture of fossil consumption is limited. It is apparent that the present energy equation is not balanced. Using up energy reserves is an untenable situation, and imbalance is reflected in our diseased biosphere. To be in balance man cannot rely on energy that is not self-renewing. Alternate energy sources, a side from being non-polluting free and independent of a politically controlled energy source as electric grid or oil (Rikoto & Garba, 2013). This self-sufficiency has important implication as the modern world comes to understand the eruptive danger of energy dependence.

Cooking in developing countries is customarily done on open fires using biomass such as firewood, charcoal, and kerosene. This process inevitably leads to excessive deforestation in these rural regions as well as considerably increases carbon-dioxide emissions. Individuals in these developing regions also suffer from respiratory infections due to significant smoke inhalation. The use of solar energy to cook food presents a viable alternative to the use of fuel wood, gas, oil and other fuels traditionally used in developing countries for the purpose of preparing food (Dhillon & Wuehlisch 2013). While certainly, solar cookers cannot entirely halt



the use of combustible fuels for food preparation, it can be shown that properly applied, solar cooking can be used as an effective mitigation tool with regards to global climate change and deforestation as well.

Solar cookers work on the basic principle of sunlight being converted to thermal energy that is retained and used for outdoor cooking purposes, and have the most positive impact in sunny, fuel-scarce regions of the world. Solar cooker is a device that cooks food stuff in catching free and plenty of sun shine (Patil & Rathore,2012). Once it is installed, the only expense is maintaining equipment's since no fuels are used. Solar energy is free from pollution of environment and not fire hazards. There are many advantages of cooking with solar energy. Since solar cookers do not requires a fire, they are not a fire hazard and can be used in areas closed to fire building. There is no smoke from a solar cooker and no ash to clean.

Solar box cooker is basically box with a glass lid that functions as an oven. Heat losses occurred over a larger surface area but it is partially offset through having a greater heat collecting surface. This type of cooker used glazed surface cover and reflectors to increase the apparent collector area (Zelege and Hameer,2018). It consists of heat trapping enclosure, which usually takes the form of a box made of insulating material with one face of the box fitted with a transparent medium either glass or plastic. This enables the cooker to utilize the greenhouse effect and incident solar radiation cooks the food within the box (Talbi & Kassmi,2018). The insulating material allows cooking temperatures to reach similar levels on cold and windy days as on hot days, as well as having an added benefit of blocking any leakages that could potentially seep through and damage the cooker.

In earlier time, cardboard and basket solar cooker were manufactured and performance evaluation of solar cookers were carried out in the center. Accordingly, cardboard and basket solar box cooker had enabled to cook effectively rice and duff having the same proportion within 2 to 3hour time interval. During the investigation, cardboard and basket solar cookers attained maximum temperature rating of 110 and 104 degree Celsius respectively. If more adiabatic system or insulating materials and reflector would be used, more temperature rating and cooking can easily be performed sooner than the former (El-Sebai, & Domanski, 1994; Algifri, A.H. & Al-Towaie, 2001). At the end of the experiment, performance evaluation of the all cookers will be carried out with comparison and finally outranking cooker will be identified. The main objective of this activity was to modify and evaluate performance of both box and basket solar cookers while keeping the environment the same for both solar gadgets.

## **Materials and Method**

### **Experimental Location**

The study was conducted in Oromia Agricultural Research Institute Bako Agricultural Engineering Research Center. The center is located in Bako Tibe District of West Shoa Zone, Oromia National Regional State, Ethiopia which is located at 250 km in the western direction from Addis Ababa on the main road via Nekemte. The altitude of the center is 1650 meters above sea level whereas latitude and longitude of study area is 9007'N and 37003'E

respectively. The mean minimum and maximum air temperatures of the location becomes 22 & 35 °C respectively.

## **Materials**

Durable basket and box solar cookers were easily be manufactured from cheap and common materials in the matter of few hours without the use of additional tools. To increase its performance and durability, the lateral surface that faced the cooking pot built with reflective material and pot sit was painted with black. Material used were aluminum foil, black paint, cardboard boxes, basket, local strew and Styrofoam as insulation materials. In this experiment, technical instruments like multi-meter, K-type thermocouple wire, contact and non-contact thermometer, thickly coated black plate with sides and bottom insulation, pan, Infrared Ray thermometer and stop watch were employed. Food item like maize, rice, egg and faba bean were used to cook each of them separately and with their combination.

## **Design Consideration and Manufacturing**

Several engineers had designed literally hundreds of different types of solar cookers. However, it is difficult to standardize and evaluate best solar cookers without considering critical factors such as cost, convenience, safety, efficiency, heating capacity, durability and simplicity. Parameters stated above were tried to be internalized during the manufacturing of all solar cookers. Normally two models of cookers were constructed. Three different basket solar cooker were prepared from strew and Styrofoam insulation as well as one with no insulation.

## **Experimental Procedure**

Experimental testing was carried out to evaluate their performance, after essential solar cookers were manufactured and made ready. The most significant parameters like angle of incidence of sun ray, material properties of collector, insulation material and properties of black body were considered during commencing of the test. Thermostat with a k-type wire for hot and cold junction were made suitable for proper measurement of temperature in terms of millivolt. The hot junction of thermostat was made in contact with the black painted plate of the basket solar boxes and box solar with proper fitting for measure. Ambient temperature was measured employing non-contact thermometer. Now, more food stuffs were planned to cook using these solar cookers with more temperature rating the formers by modifying mode and type of insulating material. For instance, food like rice, baking duff, preparing nuffuro and cooking egg were successful performed.

## **Performance of Solar Cooker**

Performance of each cookers was measured in millivolt record employing K-type thermocouple. The mv record was read by means of digital multimeter reader and converted into temperature employing standard conversion table. The mv recordings of last column alone at the right hand of the table is used to evaluate the performance of the solar box cooker with augmentative reflector.

**Cooking Power**

The primary reference measurement used by ASAE S580, 2010 is the cooking power. The cooking power and adjusted standard cooking power is calculated using the relations given below. Cooking power (Pc) for each 10-minute test is given by (ASAE,2003; Funk, 2000):

$$P_c = \frac{T_2 - T_1}{600} m C_p \dots\dots\dots 1$$

- Where: Pc = cooking power (W)
- T<sub>2</sub> = final water temperature
- T<sub>1</sub> = initial water temperature
- m = mass of water (kg)
- C<sub>p</sub> = heat capacity (4200 kJ/kg. K)

The equation is divided by 600 to account for the number of seconds in each 10-minute interval. P is normalized to a figure of 700 W/m<sup>2</sup> through the following equation.

$$P_{sc} = P_c \left( \frac{700}{G} \right) \dots\dots\dots 2$$

- Where: G = interval average irradiation (W/m<sup>2</sup>)
- P<sub>c</sub> = cooking power (W)
- P<sub>sc</sub> = standardized cooking power (Psc)

**Energy efficiency**

Based on the 1<sup>st</sup> Law of Thermodynamics

Energy input = Energy output + Energy losses

**Energy input** to the solar cooker can be calculated as follows (Mullick & Kandpal,1987):

$$E_i = G_t \chi A_{sc} \dots\dots\dots 3$$

- Where: E<sub>i</sub> is the energy input in W
- G<sub>t</sub> is total solar energy incident upon plane of the solar air being heated in W/m<sup>2</sup>
- A<sub>sc</sub> is the surface area of the solar cooker in m<sup>2</sup>

**Energy output** from the solar cooker can be found as shown below:

$$E_o = \frac{m_w c_{pw} (T_{wf} - T_{wi})}{t} \dots\dots\dots 4$$

- Where: E<sub>o</sub> is the energy output in W
- m<sub>w</sub> is the mass of water in kg
- c<sub>pw</sub> is specific heat of water in J/kgK
- A<sub>sc</sub> is the surface area of the solar cooker in m<sup>2</sup>
- T<sub>wi</sub> is the initial temperature of the water in K

$T_{wf}$  is the final temperature of the water in K

t is the time in seconds

**Therefore, energy efficiency** of the solar cooker can be found by diving eq 4 & eq 3

$$\eta = \frac{E_o}{E_i} = \frac{[m_w c_{pw}(T_{wf}-T_{wi})]}{tG_tA_{sc}} \dots\dots\dots 5$$

## Data Management and Analysis

### Calculation of Solar Irradiance

In order to calculate the solar irradiation, Engineering Equation Solver (EES) software was used to create a program that enables to execute manipulation of numerical value. It is very helpful to operate essential program to determine uneasily accessible for manual manipulation. Meanwhile, the program created looks like as follow:

```
T_air=
T_plate=
T_sky=
Tfilm= (T_Plate+T_air)/2
DELTAT=T_plate-T_air
L_c=0.1875
beta=1/ (Tfilm+273)
sigma=5.67e-8
alpha=0.95
epsilon=0.95
g=9.8
k=CONDUCTIVITY (Air, T=Tfilm)
Pr=PRANDTL (Air, T=Tfilm)
nu=VISCOSITY (Air, T=Tfilm)
Ra=g*beta*DELTAT*(L_c^3) *Pr/nu^2
Nu1=0.54*Ra^ (1/4)   For Ra (1e4, 1e7)
Nu2= 0.15*Ra^ (1/3)   For Ra (1e7, 1e11)
h1=k*Nu1/L_c
h2=k*Nu2/L_c
S1= ((h1*DELTAT) + (epsilon*sigma*(((T_plate+273) ^4) -((T_sky+273) ^4))))/alpha
S2= ((h2*DELTAT) + (epsilon*sigma*(((T_plate+273) ^4) -((T_sky+273) ^4))))/alpha
```

### Physical Feature of Solar Cookers

Physical feature box solar cooker and basket solar cooker. Box solar cooker was constructed from carboard or cartoon materials whereas basket one was constructed with locally available materials. Figure below shows an important part of the cooker and its readiness for experimental testing.

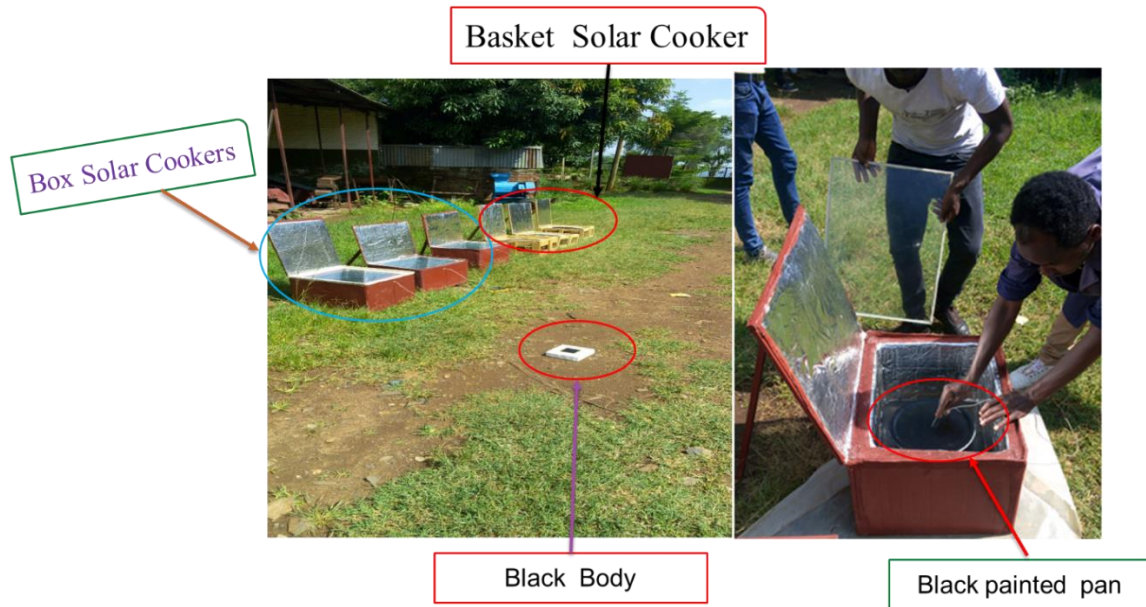

Figure 1. Physical feature of Box and Basket Solar Cookers

Table 1: -Row data collected on 23 March, 2020 while mass of 0.4kg of rice and 1.5L of water were applied in each pan of all solar cookers.

Trial No	Time Interval	Time	$T_{amb}$	$T_{sky}$	$T_{bb}$	Basket solar cooker			Box solar cooker		
						$mV_s$	$mV_{cool}$	$mV_{no}$	$mV_s$	$mV_{cool}$	$mV_{no}$
1	0	10:10	25.6	-30	60.4	0.1	0.1	0.1	0.1	0.1	0.1
2	10	10:20	25.8	-35	61.8	0.1	0.2	0.2	0.2	0.2	0.3
3	20	10:30	26.4	-29	60.4	0.2	0.3	0.4	0.3	0.3	0.5
4	30	10:40	27.4	-28	62.2	0.3	0.4	0.5	0.5	0.7	0.8
5	40	10:50	28.2	-27	64.4	0.5	0.6	0.8	0.7	0.9	1.0
6	50	11:00	29.3	-27	66.4	0.7	0.7	1.0	0.7	1.1	1.1
7	60	11:10	28.8	-33	67.2	0.8	1.0	1.2	0.9	1.3	1.3
8	70	11:20	29.4	-33	60.4	1.0	1.2	1.2	1.0	1.6	1.5
9	80	11:30	30.2	-34	69.8	1.1	1.3	1.4	1.4	1.6	1.6
10	90	11:50	30.3	-31	71.0	1.3	1.4	1.5	1.5	1.8	1.6
11	100	12:00	30.7	-30	68.5	1.4	1.5	1.5	1.6	1.9	1.8
12	110	12:10	32.2	-20	69.0	1.5	1.5	1.6	1.7	2.0	2.0
13	120	12:30	32.5	-23	75.2	1.5	1.6	1.6	1.8	2.2	2.2
14	130	12:40	32.3	-22	76.1	1.6	1.8	1.7	1.9	2.4	2.3
15	140	12:50	32.4	-21	77.2	1.7	1.9	1.8	2.0	2.6	2.4

**Description of involved terms in table**

$T_{amb}$  -Ambient temperature     $T_{sky}$  - Sky temperature

$T_{bb}$  - Black body temperature

$mV_{S Ba}$  -Mv of Solar Basket insulated with straw

$mV_{S Bo}$  - mv of Solar Box insulated with straw

$mV_{cool Ba}$  -Mv of Solar Basket insulated with styrofoam

$mV_{cool Bo}$  - mv of solar Box insulated with styrofoam

$mV_{no ins Ba}$  - Mv of Solar Basket with no insulation

$mV_{no ins Bo}$  - Mv of Solar Box with no insulation

Table 2: -Row data collected on 25 March, 2020 when mass of 0.2kg of maize and 0.4kg of bean was used in each solar cooker as well as 0.5 liter of water was applied for each cooker.

Trail No	Time Interval	Time	T <sub>amb</sub>	T <sub>sky</sub>	T <sub>bb</sub>	Basket solar cooker			Box solar cooker		
						mV <sub>s</sub>	mV <sub>tool</sub>	mV <sub>no</sub>	mV <sub>s Bo</sub>	mV <sub>tool</sub>	mV <sub>no</sub>
1	0	10:20	22.3	-17	47.8	0.0	0.1	0.1	0.1	0.1	0.1
2	10	10:30	25.8	-20	48.0	0.1	0.2	0.1	0.4	0.5	0.5
3	20	10:40	27.2	-17	56.8	0.3	0.4	0.3	0.9	0.8	0.7
4	30	10:50	28.0	-15	57.6	0.5	0.6	0.5	1.0	0.9	1.1
5	40	11:00	29.2	-17	59.2	0.8	0.8	0.6	1.3	1.2	1.4
6	50	11:10	29.2	-15	55.8	1.0	1.0	1.0	1.6	1.3	1.6
7	60	11:20	30.1	-20	57.0	1.1	1.0	1.0	1.6	1.8	1.8
8	70	11:30	30.6	-10	62.0	1.1	1.2	1.2	1.7	1.8	1.8
9	80	11:40	32.2	-8.4	64.2	1.2	1.3	1.2	1.8	1.9	1.9
10	90	11:50	30.9	-12	65.3	1.4	1.6	1.3	2.0	1.9	1.9
11	100	12:00	31.4	-9.4	67.6	1.5	1.9	1.4	2.0	2.0	2.0
12	110	12:10	30.7	-7.6	64.6	1.7	1.8	1.5	2.2	2.2	2.0
13	120	12:20	30.8	-12	63.8	1.8	1.9	1.6	2.1	2.2	2.1
14	130	12:30	31.1	-11	64.6	1.9	2.0	1.8	2.2	2.3	2.2
15	140	12:40	31.3	-12	65.3	2.0	2.0	1.9	2.2	2.3	2.2
16	150	12:50	32.1	-14	68.5	2.0	2.1	2.0	2.3	2.4	2.3
17	160	13:00	32.4	-18	69.7	2.1	2.2	2.1	2.4	2.5	2.3

Table 3: - Data Collected on Stagnation Temperature on 25 March,2020 when there was no load applied in each cooker

Trial No	Time Interval	Time	T <sub>amb</sub>	T <sub>sky</sub>	T <sub>bb</sub>	Basket solar cooker			Box solar cooker		
						mV <sub>s</sub>	mV <sub>tool</sub>	mV <sub>no</sub>	mV <sub>s</sub>	mV <sub>tool</sub>	mV <sub>no</sub>
1	0	14:00	29.8	-20	46.1	0.1	0.1	0.1	0.1	0.1	0.1
2	10	14:20	33.0	-18	48.4	0.2	0.3	0.3	1.2	1.4	1.6
3	20	14:30	33.0	-20	50.2	0.4	0.4	0.5	1.9	2.0	2.2
4	30	14:40	33.1	-15	54.1	0.6	0.7	0.8	2.3	2.4	2.6
5	40	14:50	33.2	-14	58.5	0.8	0.9	1.0	2.7	2.8	3.0
6	50	15:00	33.6	-13	69.0	1.2	1.3	1.9	3.0	3.1	3.4
7	60	15:10	32.5	-13	68.4	2.0	1.8	2.0	3.1	3.2	3.5
8	70	15:30	32.1	-12	64.4	2.6	2.0	2.1	3.4	3.4	3.5
9	80	15:40	31.6	-14	58.6	2.6	2.2	2.1	3.3	3.4	3.5
10	90	15:50	30.8	-15	58.4	2.6	2.2	2.0	3.3	3.3	3.3
11	100	16:00	30.7	-16	58.	2.5	2.2	2.0	3.2	3.3	3.3

					0						
12	110	16:10	29.6	-15	60.0	2.5	2.1	2.0	3.1	3.2	3.2
13	120	16:20	28.0	-10	54.4	2.3	2.0	1.8	2.8	2.9	3.0

Stagnation temperature rating expresses when there is no loading was applied or employed in all solar cookers. These temperature measure maximum temperature rating of any cooker with specific solar condition.

### Result and Discussion

Cardboard and Basket solar box cooker were manufactured with incorporating insulation materials that enhance or boost heat transfer and preservation in solar cooker. Totally about six prototypes were constructed and performance evaluation of all solar cooker were performed. Solar cooker performance was conducted with cooking power, standard cooking power and efficiency of cooker. All solar cookers were seriously tested with loading and unloading condition in order to identified their performance.

#### Estimation of Solar Irradiation

Instant solar irradiation for particular day was calculated using Engineering Equation Solver. Table below showed us calculated solar irradiancy of 23 march, 2020.

*Table 4 Magnitude of calculated irradiancies of 23 March,2020*

Trial No	Time Interval	Time	T <sub>amb</sub>	T <sub>skv</sub>	T <sub>bb</sub>	G	ΔG
1	0	10:10	25.6	-30	60.4	797.8	-
2	10	10:20	25.8	-35	61.8	853.0	-55.2
3	20	10:30	26.4	-29	60.4	809.8	+43.2
4	30	10:40	27.4	-28	62.2	818.8	-9.0
5	40	10:50	28.2	-27	64.4	850.3	-31.5
6	50	11:00	29.3	-27	66.4	878.3	-28.0
7	60	11:10	28.8	-33	67.2	919.6	-41.3
8	70	11:20	29.4	-33	60.4	778.4	+141.2
9	80	11:30	30.2	-34	69.8	960.4	-182.0
10	90	11:50	30.3	-31	71.0	974.7	-14.3
11	100	12:00	30.7	-30	68.5	915.3	+59.4
12	110	12:10	32.2	-20	69.0	874.2	+41.1
13	120	12:30	32.5	-23	75.2	1011.0	-136.8
14	130	12:40	32.3	-22	76.1	1029.0	-18.0
15	140	12:50	32.4	-21	77.2	1048.0	-17.0

Magnitude of solar irradiancy was calculated employing EES software. Consequently, daily maximum and minimum solar irradiancy became 1048 and 778.4 w/m<sup>2</sup> respectively. Thus, an average daily irradiancy became 913.2 w/m<sup>2</sup> when 0.4 kg of rice and 1.5L of water was set in all cookers.

Table 5: - Magnitude of calculated irradiation of 25 March ,2020

Trial No	Time Interval	Time	T <sub>amb</sub>	T <sub>sky</sub>	T <sub>bb</sub>	G	ΔG
1	0	10:10	22.3	-17	47.8	543.9	-
2	10	10:20	25.8	-20	48.0	563.9	-3.0
3	20	10:30	27.2	-17	56.8	677.8	-113.9
4	30	10:40	28.0	-15	57.6	676.7	+1.1
5	40	10:50	29.2	-17	59.2	702.1	-25.4
6	50	11:00	29.2	-15	55.8	630.7	+71.4
7	60	11:10	30.1	-20	57.0	662.6	-50.9
8	70	11:20	30.6	-10	62.0	713.3	-50.7
9	80	11:30	32.2	-8.4	64.2	732.4	-19.1
10	90	11:40	30.9	-12	65.3	783.1	-50.7
11	100	11:50	31.4	-9.4	67.6	813.1	-30.0
12	110	12:00	30.7	-7.6	64.6	753.2	+59.9
13	120	12:10	30.8	-12	63.8	754.5	-1.3
14	130	12:20	31.1	-11	64.6	763.0	-8.5
15	140	12:30	31.3	-12	65.3	778.7	-15.7
16	150	12:40	32.1	-14	68.5	840.1	-61.4
17	160	12:50	32.4	-18	69.7	878.8	-38.7

Daily Maximum and Minimum solar irradiancy become 878.8 and 543.9 w/m<sup>2</sup> respectively. Therefore, average daily irradiancy become 711.4 w/m<sup>2</sup> when 0.2kg of maize and 0.4kg of bean was used in each solar cooker.

Table 6. Magnitude of Irradiancy & Temperature for Stagnation 25 March,2020

Trail No	Time Interval	Time	T <sub>amb</sub>	T <sub>s bas</sub>	T <sub>cool bas</sub>	T <sub>no insu bas</sub>	T <sub>s box</sub>	T <sub>cool box</sub>	T <sub>no insu box</sub>	G	ΔG
1	0	13:50	29.8	32.6	32.6	32.6	32.6	32.6	32.6	474.1	-
2	10	14:00	33.0	34.9	37.8	37.8	59.9	64.1	69.1	475.9	-1.8
3	20	14:20	33.0	37.8	39.9	42.7	76.1	78.8	83.9	513.4	-37.5
4	30	14:30	33.1	44.6	47.8	50.0	86.1	88.7	93.1	561.2	-47.8
5	40	14:40	33.2	50.0	52.1	54.8	93.1	95.4	100.8	636.0	-74.8
6	50	14:50	33.6	59.9	61.8	76.1	100.8	102.6	110.2	831.9	-195.9
7	60	15:00	32.5	78.8	73.9	78.8	102.6	105.2	115.2	832.8	-0.9
8	70	15:10	32.1	86.1	78.8	81.2	110.2	110.2	115.2	752.3	+80.5
9	80	15:20	31.6	88.7	83.9	81.2	107.8	110.2	115.2	705.5	+46.8
10	90	15:30	30.8	90.8	83.9	78.8	107.8	107.8	107.8	662.6	+42.6
11	100	15:40	30.7	88.7	83.9	78.8	105.2	107.8	107.8	660.0	+2.6
12	110	15:50	29.6	88.7	81.2	78.8	102.6	105.2	105.2	644.0	+16.0
13	120	16:00	28.0	86.1	78.8	73.9	95.4	98.1	100.8	597.2	+46.8

Daily maximum and minimum solar irradiancy become 878.8 and 543.9 w/m<sup>2</sup> respectively. Thus, average daily irradiancy become 711.4 w/m<sup>2</sup>. Maximum and minimum temperature in box solar cooker become 115.2 and 32.6 0c registered in box solar cooker with no insulation whereas maximum and minimum temperature of in basket solar cooker become 90.8 and 32.6 0c registered in basket solar cooker with straw insulation.



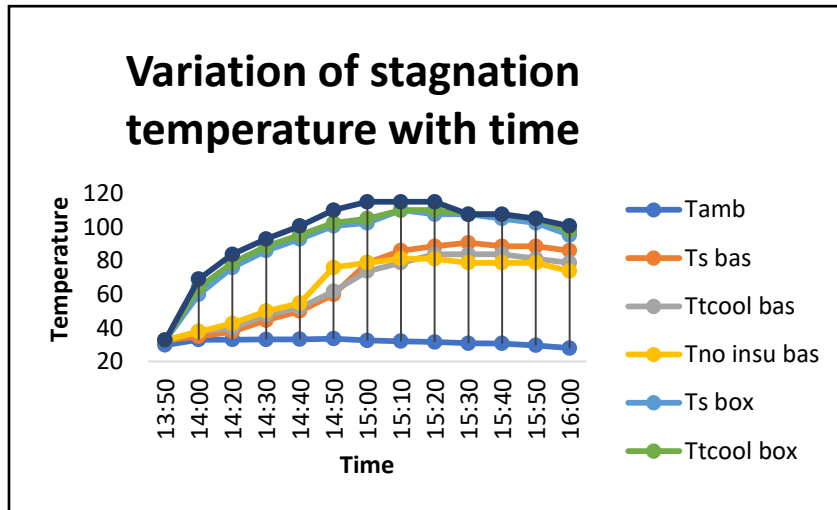

Figure 2. Stagnation Temperature of all box and basket solar cookers during 25 March, 2020

Table 7 Cooking power, corrected cooking power and efficiency of Basket solar cooker Important parameter used to estimate solar cooker performance measurements are stated as fellow. Thus, solar Irradiation, cooking power and efficiency of Basket Solar Cooker while cooking 0.4kg of rice and 1.5L of water were applied in each pan of basket solar cooker.

$G_t$	$G_{ave}$ g	$T_a$ mb	Basket with Strew				Basket with Thermo-cool				Basket without insulation			
			$T_s$	$P_{cS}$	$P_{sc S}$	$\eta_s$	$T_{icool}$	$P_{ctool}$	$P_{sc tool}$	$\eta_{tcool}$	$T_{noinsu}$	$P_{c noins}$	$P_{sc noins}$	$\eta_{noins}$
797.8	0	25.6	21.5	0	0	0	24.3	0	0	0	24.5	0	0	0
853.0	825.4	25.8	24.5	31.35	25.73	0.1745	26.8	26.16	21.44	0.1454	26.8	24.04	19.73	0.1338
809.8	831.4	26.4	26.8	24.04	20.78	0.1409	29.5	28.23	24.39	0.1654	31.8	52.25	45.17	0.3064
818.8	814.3	27.4	29.5	28.23	24.13	0.1636	31.8	24.04	20.55	0.1394	34.3	26.13	22.33	0.1515
850.3	834.55	28.2	34.3	50.16	41.29	0.2800	36.9	53.29	43.87	0.2975	41.3	73.15	60.22	0.4084
878.3	864.3	29.3	39.1	50.16	39.98	0.2711	39.1	22.99	18.33	0.1243	46.4	53.29	42.48	0.2881
919.6	898.95	28.8	41.3	22.99	17.53	0.1187	46.6	78.38	59.66	0.4046	51.1	49.12	37.39	0.2536
778.4	849.0	29.4	46.4	53.29	47.93	0.3251	51.5	51.21	46.05	0.3123	51.1	0	0	0
960.4	869.4	30.2	48.6	22.99	16.76	0.1137	53.2	17.77	12.95	0.0878	56.6	57.48	41.89	0.2841
974.7	967.55	30.3	53.2	48.07	34.52	0.2372	56.6	35.53	25.52	0.1778	58.3	17.77	12.76	0.08

						41				31				65
915.3	945.0	30.7	56.6	35.53	27.18	0.1843	58.3	17.77	13.59	0.0921	58.3	0	0	0
874.2	894.75	32.2	58.3	17.77	14.23	0.0965	58.3	0	0	0	61.3	31.35	25.11	0.1703
1011.0	942.6	32.5	58.3	0	0	0	61.3	31.35	21.71	0.1472	61.3	0	0	0
1029.0	1020.0	32.3	61.1	29.26	19.91	0.1349	65.4	42.85	29.15	0.1977	63.2	19.86	13.51	0.0917
1048.0	1038.5	32.4	63.2	21.95	14.66	0.0994	68.5	32.39	21.64	0.1468	65.4	22.99	15.36	0.1042
				435.79	344.63	0.1558		461.96	358.85	0.1622		427.43	335.95	0.1519

Average cooking power, standard cooking power and efficiency of basket solar cooker insulated with strew become 435.79,344.63 and 0.1558 respectively. Average cooking power, standard cooking power and efficiency of basket solar cooker insulated with Styrofoam become 461.96,358.85 and 0.1625 respectively. Average cooking power, standard cooking power and efficiency of basket solar cooker insulated with strew become 427.4,335.95 and 0.1519 respectively. At post of cooking, all cookers cooked rice but Styrofoam insulated cooker cooked best among three cookers. Few waters were left in non-insulated cooker and very few lefts in straw cooker post cooking.

Table 8. Cooking power, Standard cooking power & Efficiency of Box solar cooker  
Important parameter used to estimate solar cooker performance measurement are stated as fellow. Thus, solar Irradiation, cooking power and efficiency of Basket Solar Cooker while cooking 0.4kg of rice and 1.5L of water were applied in each pan of box solar cooker.

G <sub>t</sub>	G <sub>ave</sub> g	T <sub>a</sub> mb	Box with Strew Insulation				Box with Thermo-cool Insulation				Box with no Insulation			
			T <sub>s</sub>	P <sub>c</sub> s	P <sub>sc</sub> s	η <sub>s</sub>	T <sub>tc</sub> ool	P <sub>c</sub> tcool	P <sub>sc</sub> tcool	η <sub>t</sub> tcool	T <sub>no</sub> insu	P <sub>c</sub> no ins	P <sub>sc</sub> no ins	η <sub>no</sub> ins
797.8	0	25.6	24.5	0	0	0	24.5	0	0	0	24.5	0	0	0
853	825.4	25.8	26.8	24.04	20.38	0.1167	26.8	24.04	20.39	0.1167	29.5	52.25	44.32	0.2506
809.8	831.4	26.4	29.5	28.215	23.76	0.1443	29.5	28.22	23.76	0.1443	34.3	50.16	42.24	0.2534
818.8	814.3	27.4	34.3	50.16	43.12	0.2537	39.1	100.32	86.24	0.5073	41.3	73.15	62.88	0.3655
850.3	834.55	28.2	39.1	50.16	42.07	0.2443	44.1	52.25	43.83	0.2544	46.4	53.29	44.71	0.2564
878.3	864.3	29.3	39.1	0	0	0	48.6	47.025	38.09	0.2217	48.6	22.99	18.62	0.1071
919.6	898.95	28.8	44.1	52.25	40.69	0.2353	53.2	48.07	37.43	0.2165	53.2	48.07	37.44	0.2138

778.4	849	29.4	46.4	24.04	19.82	0.1279	61.1	82.56	68.07	0.4392	58.3	53.29	43.95	0.2801
960.4	869.4	30.2	56.6	106.59	85.82	0.4596	61.1	0	0	0	61.1	29.26	23.56	0.1247
974.7	967.55	30.3	58.3	17.77	12.85	0.0755	65.4	44.93	32.51	0.1909	61.1	0	0	0
915.3	945	30.7	61.1	29.26	21.67	0.1324	68.5	32.39	23.99	0.1466	65.4	44.94	33.29	0.2009
874.2	894.75	32.2	63.2	21.95	17.17	0.1039	70.8	24.035	18.80	0.1138	70.8	56.43	44.15	0.2641
1011.0	942.6	32.5	65.4	22.99	17.07	0.0942	75.7	51.205	38.03	0.2097	75.7	51.205	38.03	0.2072
1029.0	1020	32.3	68.5	32.39	22.23	0.1304	85.1	98.23	67.42	0.3953	82.7	73.15	50.21	0.2908
1048.0	1038.5	32.4	70.8	24.04	16.21	0.0949	87.4	24.04	16.21	0.0949	85.1	25.08	16.91	0.0979
Mean				483.855	382.86	0.1475		657.315	514.77	0.2034		633.265	500.31	0.1942

Average cooking power, standard cooking power and efficiency of basket solar cooker insulated with straw become 485.85,382.86 and 0.1475 respectively. Average cooking power, standard cooking power and efficiency of basket solar cooker insulated with Styrofoam become 657.15,514.77 and 0.2034 respectively. Average cooking power, standard cooking power and efficiency of basket solar cooker insulated with strew become 633.26,500.31 and 0.1942 respectively. At post of cooking, all box solar cooker cooked rice well. Very few waters were left in straw insulated cooker at the end of the operation.

**Table 9. Cooking power, Standard cooking power & Efficiency of Basket solar cooker**

Important parameter used to estimate solar cooker performance measurement are stated as follow. Thus, solar Irradiation, cooking power and efficiency of Basket Solar Cooker while cooking mass of 0.2kg of maize and 0.4kg of bean was used in each solar cooker as well as 0.5 liter of water was applied for each basket solar cooker.

G <sub>t</sub>	G <sub>aveg</sub>	T <sub>a</sub> mb	Basket with Strew				Basket with Thermo-cool				Basket without insulation			
			T <sub>s</sub>	P <sub>c</sub> S	P <sub>sc</sub> S	η <sub>s</sub>	T <sub>tc</sub> ool	P <sub>c</sub> tcool	P <sub>sc</sub> Tcool	η <sub>tcool</sub>	T <sub>no</sub> insu	P <sub>c</sub> no ins	P <sub>sc</sub> no ins	η <sub>no</sub> ins
543.9	0	22.3	22	0	0	0	22	0	0	0	22	0	0	0
563.9	553.9	25.8	24.5	26.13	33.02	0.1481	24.5	26.13	33.02	0.1481	24.5	26.13	33.02	0.1481
677.8	620.85	27.2	29.5	52.25	58.97	0.2464	31.8	76.29	86.01	0.3597	29.5	52.25	58.91	0.2465
676.7	677.25	28.3	34.3	50.16	51.85	0.2369	36.9	53.29	55.09	0.2517	34.3	50.16	51.85	0.2369
702.1	689.4	29.2	41.3	73.15	74.27	0.3330	41.3	45.98	46.69	0.2093	36.9	27.17	27.59	0.1237
630.7	666.4	29.2	46.4	53.29	55.98	0.2701	46.4	53.29	55.98	0.2701	41.3	45.98	48.29	0.2330

662.6	646.65	30.1	48.6	22.99	24.89	0.1109	46.4	0	0	0	46.4	53.29	57.69	0.2571
713.3	687.95	30.6	48.6	0	0	0	51.1	49.12	49.98	0.2200	51.1	49.12	49.98	0.2200
732.4	722.85	32.2	51.1	26.13	25.29	0.1140	53.2	21.95	21.25	0.0958	51.1	0	0	0
783.1	757.75	30.9	56.6	57.48	53.09	0.2346	61.1	82.56	76.26	0.3369	53.2	21.95	20.27	0.0896
813.1	798.1	31.4	58.3	17.77	15.58	0.0698	68.5	77.33	67.83	0.3040	56.6	35.53	31.16	0.1397
753.2	783.15	30.7	63.2	51.21	45.77	0.2173	65.4	-32.39	-28.96	-0.1375	58.3	17.77	15.88	0.0754
754.5	753.85	30.8	65.4	22.99	21.35	0.0974	68.5	32.39	30.08	0.1372	61.1	29.26	27.17	0.1239
763	758.75	31.1	68.5	32.39	29.89	0.1357	70.8	24.04	22.17	0.1007	65.4	44.94	41.46	0.1883
778.7	770.85	31.3	70.8	24.03	21.83	0.0986	70.8	0	0	0	68.5	32.39	29.42	0.1329
840.1	809.4	32.1	70.8	0	0	0	73.1	24.04	20.78	0.0915	70.8	24.04	20.78	0.0915
878.8	859.45	32.4	73.1	24.03	19.58	0.0874	75.7	27.17	22.13	0.0988	73.1	24.03	19.58	0.0874
Mean				<b>534.08</b>	<b>531.36</b>	<b>0.1412</b>		<b>561.19</b>	<b>558.31</b>	<b>0.1463</b>		<b>534.05</b>	<b>533.05</b>	<b>0.1408</b>

Average cooking power, standard cooking power and efficiency of basket solar cooker insulated with strew become 534.01, 531.42 and 0.1412 respectively. Average cooking power, standard cooking power and efficiency of basket solar cooker insulated with Styrofoam become 561.20, 558.31 and 0.1463 respectively. Average cooking power, standard cooking power and efficiency of box solar cooker insulated with strew become 534.05, 533.05 and 0.1408 respectively. At post of cooking, basket solar cooker insulated with Styrofoam cooked maize and bean together better the remaining basket solar cookers.

Table 10. Cooking power, Standard cooking power & Efficiency of Box Solar Cooker  
Important parameter used to estimate solar cooker performance measurement are stated as follow. Thus, solar Irradiation, cooking power and efficiency of Basket Solar Cooker while cooking mass of 0.2kg of maize and 0.4kg of bean was used in each solar cooker as well as 0.5 liter of water was applied for each box solar cooker

G <sub>t</sub>	G <sub>aveg</sub>	T <sub>a</sub> mb	Box with Strew Insulation				Box with Thermo-cool Insulation				Box with no Insulation			
			T <sub>s</sub>	P <sub>c</sub> s	P <sub>sc</sub> s	η <sub>s</sub>	T <sub>tc</sub> ool	P <sub>c</sub> tcool	P <sub>sc</sub> tcool	η <sub>t</sub> tcool	T <sub>no</sub> insu	P <sub>c</sub> no ins	P <sub>sc</sub> no ins	η <sub>no</sub> ins
543.9	0	22.3	24.5	0	0	0	24.5	0	0	0	24.5	0	0	0
563.9	553.9	25.8	31.8	76.29	96.40	0.3673	34.3	102.41	129.42	0.4930	34.3	102.41	129.42	0.4931
677	620.	27	44	128.	144.	0.51	41.	73.1	82.4	0.29	39.	50.1	82.48	0.20

.8	85	.2	.1	54	92	49	3	5	7	30	1	6		09
676	677.	28	46	24.0	24.8	0.09	44.	29.2	30.2	0.11	48.	99.2	30.24	0.39
.7	25		.4	4	4	64	1	6	4	74	6	8		83
702	689.	29	53	71.0	72.1	0.27	51.	73.1	74.2	0.28	56.	83.6	74.27	0.32
.1	4	.2	.2	6	5	48	1	5	7	28	6			33
630	666.	29	56	35.5	37.3	0.15	53.	21.9	23.0	0.09	61.	47.0	23.05	0.20
.7	4	.2	.6	3	2	29	2	5	5	45	1	3		24
662	646.	30	61	47.0	50.9	0.19	61.	82.5	89.3	0.33	63.	21.9	89.37	0.08
.6	65	.1	.1	3	0	28	1	6	6	87	2	5		99
713	687.	30	63	21.9	22.3	0.08	65.	44.9	45.7	0.17	65.	22.9	45.72	0.08
.3	95	.6	.2	5	28	35	4	4	2	10	4	9		75
732	722.	32	65	22.9	22.2	0.08	68.	32.4	31.3	0.12	68.	32.4	31.37	0.12
.4	85	.2	.4	9	6	52	5	0	7	01	5	0		01
783	757.	30	68	32.4	29.9	0.11	68.	0	0	0	68.	0	0	0
.1	75	.9	.5	0	2	23	5				5			
813	798.	31	70	24.0	21.0	0.08	70.	24.0	21.0	0.08	70.	24.0	21.08	0.08
.1	1	.4	.8	4	8	03	8	4	8	03	8	4		02
753	783.	30	70	0	0	0	73.	24.0	21.4	0.08	70.	0	21.48	0
.2	15	.7	.8				1	4	8	66	8			
754	753.	30	73	24.0	22.3	0.08	75.	27.1	25.2	0.09	73.	24.0	25.24	0.08
.5	85	.8	.1	4	1	65	7	7	3	78	1	4		65
763	758.	31	75	27.1	25.0	0.09	77.	21.9	20.2	0.07	75.	27.1	20.25	0.09
.0	75	.1	.7	7	6	67	8	5	5	80	7	7		7
778	770.	31	75	0	0	0	77.	0	0	0	75.	0	0	0
.7	85	.3	.7				8				7			
840	809.	32	77	21.9	18.9	0.07	80.	27.1	23.4	0.08	77.	21.9	23.49	0.07
.1	4	.1	.8	5	7	09	4	7	9	78	8	5		09
878	859.	32	80	27.1	22.1	0.08	82.	24.0	19.5	0.07	77.	0	19.58	0
.8	45	.4	.4	7	2	39	7	4	8	43	8			
Mean				<b>584.</b>	<b>610.</b>	<b>0.13</b>		<b>608.</b>	<b>637.</b>	<b>0.14</b>		<b>557.</b>	<b>637.0</b>	<b>0.13</b>
				<b>2</b>	<b>58</b>	<b>52</b>		<b>23</b>	<b>01</b>	<b>21</b>		<b>02</b>	<b>42</b>	<b>25</b>

Average cooking power, standard cooking power and efficiency of box solar cooker insulated with straw become 584.2, 610.58 and 0.1352 respectively. Average cooking power, standard cooking power and efficiency of box solar cooker insulated with Styrofoam become 608.23, 637.01 and 0.1421 respectively. Average cooking power, standard cooking power and efficiency of box solar cooker insulated with strew become 557.02, 637.05 and 0.1325 respectively. At post of cooking, box solar cooker insulated with Styrofoam and no insulation cooked maize and bean together than straw insulated box solar cookers.

## **Conclusion and Recommendation**

The study was conducted to investigate and compare performance of basket and box solar cooker under various solar insolation. On this time, six solar cookers were parallel tested within the same environmental condition. From the experimental result obtained, it was observed that various parameters were engaged to determine importunacy of the cookers. Cooking power, standard cooking power and efficiency of all basket and box solar cooker insulated with local straw, Styrofoam and with no insulation for rice and maize cooking have been investigated and comparison was done.

Basket solar cooker that insulated with Styrofoam cooked given rice with better rating than the remaining basket solar cookers. However, all basket solar cookers with straw, Styrofoam and no insulation registered maximum temperature of 63.2, 68.5 and 65.4 0c that is above 60 0c which is suitable for cooking of certain foods. In case of cooking maize with bean, again still basket solar cooker insulated with Styrofoam insulation performed better cooking than the remaining basket solar cookers. However, maize required intensive heat to be cooked well when it is compared with rice, bean and egg. Faba been was added after 60 minute later.

All basket solar cookers with straw, Styrofoam and no insulation attained maximum temperature of 73.1, 75.7 and 73.5 0c respectively. These temperatures are still above 60 0c supposed to be recommend for cooking temperature of certain food item whereas all box solar cookers cooked rice food well. However, at the end of test, very few waters were left in rice cooked with straw insulated cooker. This is due to heat retention rate in the straw was very low when compared with Styrofoam insulation materials. Here all box solar cookers with straw, Styrofoam and no insulation attained maximum temperature of 70.8, 87.4 and 85.4 0c respectively.

When maize and bean were cooked with box solar cooker, at the end of the test, Styrofoam and no insulated box solar cooked them together better than straw box solar cooker. At post of maize and bean cooking, all box solar cookers with straw, Styrofoam and no insulation attained maximum temperature of 80.4, 82.7 and 77.8 0c respectively. Above stated temperatures are good rating for cooking and boiling of several food stuff in better condition.

### **Recommendation**

Styrofoam insulated basket and box solar cookers exceedingly accomplished their task in both cooking performance test. Box solar cooker insulated with Styrofoam performed better than basket solar cooker in cooking power, standard cooking power and efficiency in all cooking operation. It's temperature rating also best among all solar gadgets. Therefore, it was identified as good performers.

Moreover, it is easy to construct and very economical when compared to that of basket solar cooker. Based on the above parameters, box solar cooker insulated with Styrofoam can be recommended to be used in household level where solar radiation is available for cooking.

## Referance

- [1]. I. I. Rikot and I. Garba, Comparative Analysis on Solar Cooking Using Box Type Solar Cooker with Finned Cooking Pot, *International Journal of Modern Engineering Research*, ISSN: 2249-6645, Vol.3, Issue.3, May-June. 2013 pp-1290-1294.
- [2]. R. S. Dhillon and George von Wuehlisch. Mitigation of global warming through renewable biomass, *Biomass and Bioenergy Journal*, Vol 48 (2013), pp75-89.
- [3]. R. C. Patil, M. M. Rathore and M.K. Chopra, An Overview of Solar Cookers, *International Conference on Recent Trends in Engineering & Technology*, Special Issue of *International Journal of Electronics, Communication & Soft Computing Science & Engineering*, ISSN: 2277-9477, Mar-2012.
- [4]. Zeleke Ademe and Sameer Hameer, Design, construction and performance evaluation of a box type solar cooker with a glazing wiper mechanism, *AIMS Energy*, DOI:10.3934/energy.2018.1.146, 6(1): 146–169, 2018.
- [5]. S. Talbi, K. Kassmi, A. Lamkaddem and R. Malek, Design and realization of a box type solar cooker with thermal storage dedicated to the rural regions of the oriental district, *Journal of Materials and Environmental Sciences*, ISSN: 2028-2508, Volume 9, Issue 4, 2018, Page 1266-1284.
- [6] El – Sebaii, A.A. & R. Domanski, R. Experimental and Theoretical Investigation of a Box Type Solar Cooker with Multi-Step inner Reflectors», *Energy*, Vol. 19, No. 10, 1994, pp. 1011-1021
- [7] Algifri, A.H. & Al-Towaie, H.A., Efficient orientation impacts of box-type solar cooker on the cooker performance, *Solar Energy*, Vol. 70, No. 2, 2001, pp 165-170.
- [8]. American Society of Agricultural Engineers, Testing and Reporting Solar Cooker Performance, ASAE-The Society for engineering in agricultural, food, and biological systems 2950 Niles Rd., St. Joseph, MI 49085-9659, USA, ASAE, S580 JAN03,2003.
- [9]. Funk, P.A. 2000. Evaluating the international standard procedure for testing solar cookers and reporting performance. *Solar Energy* 68(1): pp 1–7.
- [10]. Mullick S.C., Kandpal T.C., and Saxena A.K. 1987. Thermal test procedure for box-type solar cookers. *Solar Energy* 39(4): pp, 353–360